

\*\*\* MODEL VRK5874 & VRK5874HF - VALVE REPAIR KITS INCLUDE THESE ITEMS (SEE SHEET 3 OF 3 FOR REPLACEMENT INSTRUCTIONS)

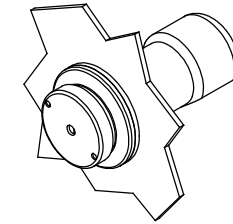

ASSEMBLED 5874PBF  
(FLUSH MOUNT APPLICATION ONLY)

**SEE SHEET 2 OF 3 FOR 5874PB RECESSED MOUNT INSTRUCTIONS.**

## INSTALLATION/REPLACEMENT INSTRUCTIONS FOR 5874PBF

- 1) FOLLOW INSTRUCTIONS CAREFULLY ON O&M MANUAL (PAGE 2 OF 7) WHEN REMOVING OLD VALVE. **NOTE: SEE PARTS BREAKDOWN (PAGE 4 OF 7) FOR ADDITIONAL NOTES.**
- 2) VERIFY THAT LOCK NUT, FIBER, AND RUBBER WASHERS ARE POSITIONED SLIGHTLY PAST MIDWAY OF THREADS ON NEW VALVE BODY.
- 3) INSERT VALVE INTO BRACKET FROM INSIDE AND PUSH FORWARD ABOUT 1".
- 4) THREAD LARGE RING NUT ONTO VALVE BODY, APPROXIMATELY 1" INTO VALVE.
- 5) PLACE WAVE WASHER INSIDE OF FLANGED PUSH BUTTON ASSEMBLY (**MUST ALWAYS BE IN PLACE**).
- 6) APPLY ONE (1) DOT OF LOCTITE 222MS, ON THE FEMALE THREADS OF BUTTON ASSEMBLY LEAVING THE FIRST AND LAST THREADS FREE. (FIGURE 1). **CAUTION: EXCESS LOCTITE CAN CAUSE THREADS TO LOCK VERY TIGHTLY, MAKING REPAIRS DIFFICULT.**
- \*\*7) THREAD FLANGED PUSH BUTTON ASSEMBLY ON VALVE UNTIL WAVE WASHER MAKES SLIGHT CONTACT WITH STEM OF CARTRIDGE. **CAUTION: DO NOT HAND-TIGHTEN.**
- 8) UNTHREAD RING NUT FORWARD UNTIL IT STOPS FLUSH WITH PUSH BUTTON ASSEMBLY.
- 9) PUSH VALVE BACK TOWARD THE INSIDE OF BRACKET AND TIGHTEN LOCKNUT (SEE ILLUSTRATION ABOVE).
- 10) TIGHTEN PUSH BUTTON ASSEMBLY USING UNIVERSAL SPANNER WRENCH PROVIDED WITH MODEL 5874PBF.

\*\* OVERTIGHTENING WILL PRE-ACTUATE VALVE AND CAUSE WEEPAGE, WHILE NOT ENOUGH CONTACT BETWEEN WAVE WASHER AND STEM CAN CAUSE A LOW FLOW CONDITION.

\* 6 APPLY 1 DOT OF LOCTITE 222MS (WHERE SHOWN)

\* THIS ALSO APPLIES TO PBA6/PBA6C

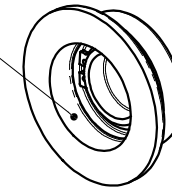
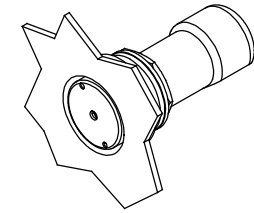
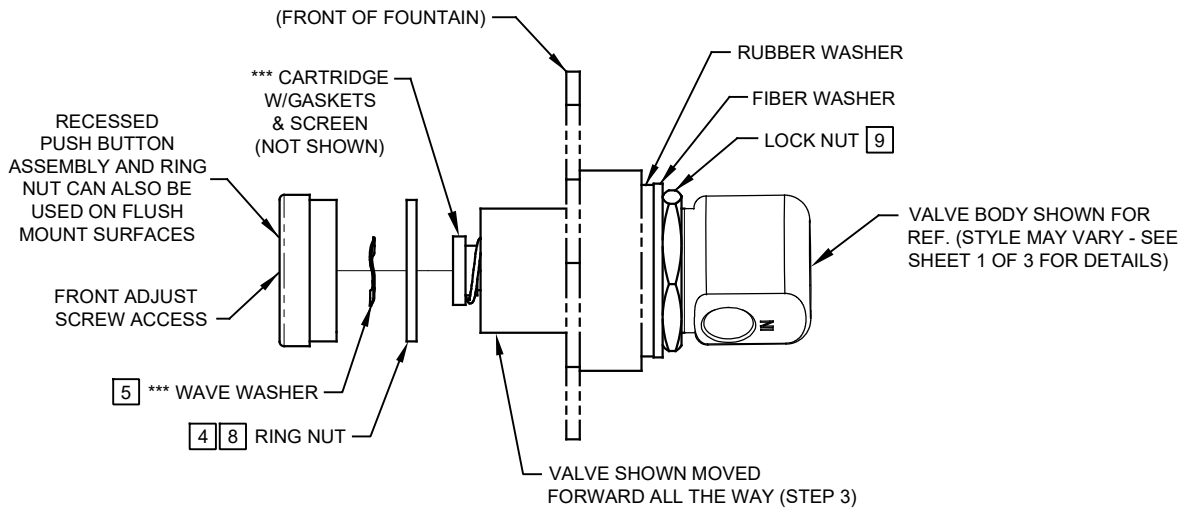

FIGURE 1

### NOTE!

THIS VALVE IS PRESSURE COMPENSATING. BE SURE TO REMOVE ANY EXISTING FLOW CONTROL DEVICES. (MAY BE PRESENT IN FITTING OR SPUD).

		<b>Haws</b> ®		1455 KLEPPE LANE SPARKS, NEVADA 89431 (775) 359-4712 FAX (775) 359-7424 E-MAIL: HAWS@HAWSCO.COM WEBSITE: WWW.HAWSCO.COM	
ECN NO. 4250	REVISED PER ECN: 5945	BY: FV	MODEL(S)		PART NUMBER
DRAWN: LM	DATE: 06/08/16	CHKD.: JC	5874PB/5874PBF/VRK5874/VRK5874HF/ PBA6/PBA6C/PBA7/PBA7C		0002077650.D
APPROVED: FV	DATE: 09/27/23	SCALE: NA	DRAWING TYPE:	INSTALLATION	REVISION 11
				SIZE: A	SHEET 1 OF 3



ASSEMBLED 5874PB  
(RECESSED MOUNT APPLICATION SHOWN)  
**SEE SHEET 1 OF 3 FOR FLUSH MOUNT INSTRUCTIONS.**

\*\*\* MODEL VRK5874 & VRK5874HF - VALVE REPAIR KITS INCLUDE THESE ITEMS  
(SEE SHEET 3 OF 3 FOR REPLACEMENT INSTRUCTIONS)

### INSTALLATION/REPLACEMENT INSTRUCTIONS FOR 5874PB

- 1) FOLLOW INSTRUCTIONS CAREFULLY ON O&M MANUAL (PAGE 2 OF 7) WHEN REMOVING OLD VALVE. **NOTE: SEE PARTS BREAKDOWN (PAGE 4 OF 7) FOR ADDITIONAL NOTES.**
- 2) VERIFY THAT LOCK NUT, FIBER WASHER, AND RUBBER WASHERS ARE POSITIONED TOWARD BOTTOM END OF THREADS ON NEW VALVE BODY.
- 3) INSERT VALVE INTO BRACKET FROM INSIDE, AND PUSH ALL THE WAY FORWARD (SEE ILLUSTRATION ABOVE).
- [4] THREAD RING NUT ONTO VALVE BODY, AS FAR IN AS POSSIBLE, TOWARD FRONT OF FOUNTAIN. **NOTE: IF REPLACING A 5871 OR 5872 SERIES VALVE, YOU MAY HAVE TO CONTACT HAWS TECHNICAL SUPPORT.**
- [5] PLACE WAVE WASHER INSIDE OF PUSH BUTTON ASSEMBLY (**MUST ALWAYS BE IN PLACE**).
- [6] APPLY ONE (1) DOT OF LOCTITE 222MS, ON THE FEMALE THREADS OF BUTTON ASSEMBLY LEAVING THE FIRST AND LAST THREADS FREE. (FIGURE 1). **CAUTION: EXCESS LOCTITE CAN CAUSE THREADS TO LOCK VERY TIGHTLY, MAKING REPAIRS DIFFICULT.**
- \*\*7) THREAD PUSH BUTTON ASSEMBLY ON VALVE UNTIL WAVE WASHER MAKES SLIGHT CONTACT WITH STEM OF CARTRIDGE. **CAUTION: DO NOT HAND-TIGHTEN.**
- [8] UNTHREAD RING NUT FORWARD UNTIL IT STOPS FLUSH WITH PUSH BUTTON ASSEMBLY.
- [9] PUSH VALVE BACK TOWARD THE INSIDE OF BRACKET AND TIGHTEN LOCKNUT (SEE ILLUSTRATION ABOVE).
- 10) TIGHTEN PUSH BUTTON ASSEMBLY USING UNIVERSAL SPANNER WRENCH PROVIDED WITH MODEL 5874PB.

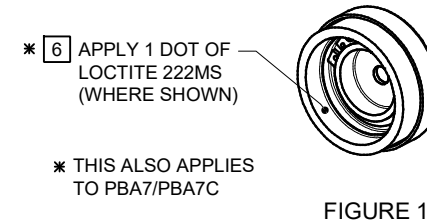

FIGURE 1

**NOTE!**  
THIS VALVE IS PRESSURE COMPENSATING. BE SURE TO REMOVE ANY EXISTING FLOW CONTROL DEVICES. (MAY BE PRESENT IN FITTING OR SPUD).

\*\* OVERTIGHTENING WILL PRE-ACTUATE VALVE AND CAUSE WEEPAGE, WHILE NOT ENOUGH CONTACT BETWEEN WAVE WASHER AND STEM CAN CAUSE A LOW FLOW CONDITION.

		1455 KLEPPE LANE SPARKS, NEVADA 89431 (775) 359-4712 FAX (775) 359-7424 E-MAIL: HAWS@HAWS.CO.COM WEBSITE: WWW.HAWS.CO.COM	
		ECN NO. 4250 DRAWN: LM APPROVED: FV	REVISED PER BY: ECN: 5945 FV DATE: 06/08/16 DATE: 09/27/23
SCALE: NA		DRAWING TYPE: INSTALLATION	
SIZE: A		SHEET 2 OF 3	

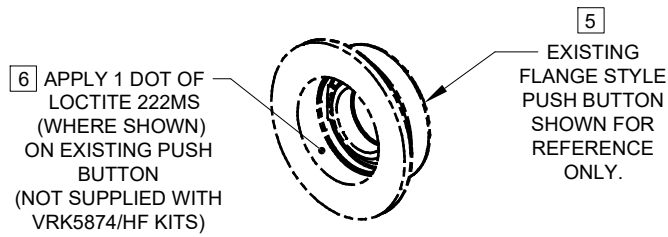
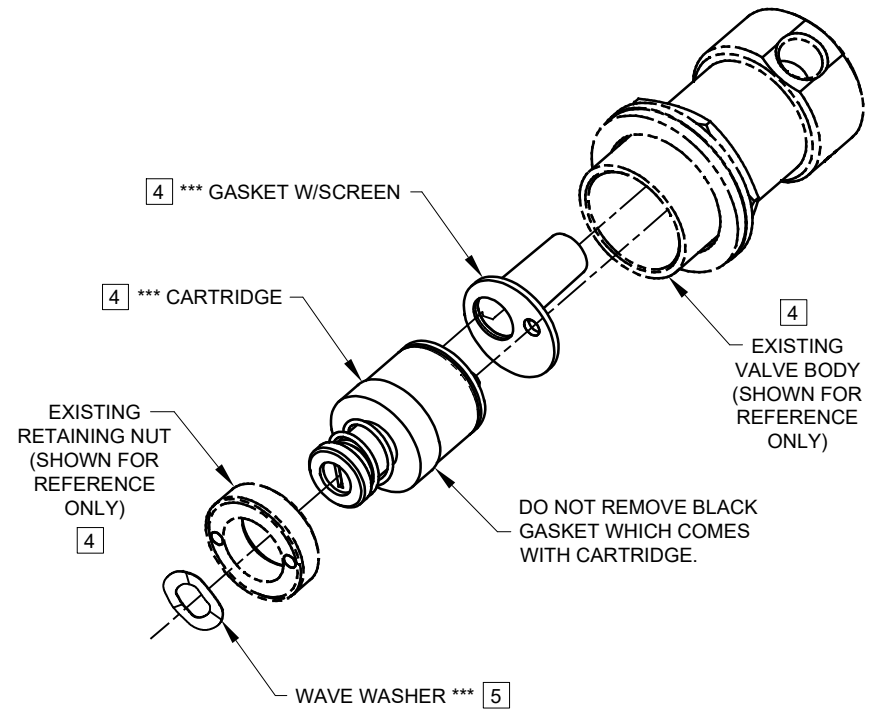

FIGURE 1

## REPLACEMENT INSTRUCTIONS FOR VRK5874/VRK5874HF

- 1) FOLLOW INSTRUCTIONS CAREFULLY ON O&M MANUAL (PAGE 2 OF 7) WHEN REMOVING VALVE. **NOTE: SEE PARTS BREAKDOWN (PAGE 4 OF 7) FOR ADDITIONAL NOTES.**
- 2) REMOVE FRONT PUSH BUTTON (WITH WAVE WASHER INSIDE) AND RETAINING NUT WITH THE UNIVERSAL SPANNER WRENCH (PN 0006983506 - NOT SUPPLIED WITH VRK5874 AND VRK5874HF KITS).
- 3) PULL EXISTING CARTRIDGE ASSEMBLY WITH GASKET SCREEN OUT.
- 4) WHEN INSERTING NEW CARTRIDGE ASSEMBLY WITH GASKET SCREEN, FOLLOW THESE IMPORTANT STEPS:
  - MAKE SURE THERE IS NO DEBRIS IN THE VALVE BODY BEFORE INSERTING THE CARTRIDGE ASSEMBLY INTO THE VALVE BODY.
  - ALIGN STRAINER WITH LARGE HOLE IN THE VALVE BODY AND ENSURE THE OUTLET PORT ON CARTRIDGE IS ALSO PROPERLY ALIGNED WITH SMALLER OPENING IN VALVE BODY BY TURNING SLIGHTLY INTO PLACE.
  - CONFIRM CARTRIDGE HAS BOTTOMED OUT PROPERLY BEFORE INSTALLING RETAINING NUT.
  - THREAD RETAINING NUT UNTIL IT CONTACTS THE CARTRIDGE, THEN TIGHTEN 1-1/4 TURN FARTHER, CHECK FOR LEAKS.
  - **(CAUTION: WHEN REPLACING CARTRIDGE W/GASKET ASSEMBLY, DAMAGE CAN OCCUR IF NOT PROPERLY RE-INSTALLED).**
- 5) PLACE WAVE WASHER (EXISTING OR NEW) INSIDE OF PUSH BUTTON ASSEMBLY (**MUST ALWAYS BE IN PLACE**).
- 6) APPLY ONE (1) DOT OF LOCTITE 222MS, ON THE FEMALE THREADS OF EXISTING BUTTON ASSEMBLY LEAVING THE FIRST AND LAST THREADS FREE. (SEE FIGURE 1). **CAUTION: EXCESS LOCTITE CAN CAUSE THREADS TO LOCK VERY TIGHTLY, MAKING REPAIRS DIFFICULT.**
- \*\* 7) THREAD EXISTING PUSH BUTTON ASSEMBLY ON VALVE UNTIL WAVE WASHER MAKES SLIGHT SLIGHT CONTACT WITH STEM OF CARTRIDGE. **CAUTION: DO NOT HAND-TIGHTEN.**
- 8) TIGHTEN EXISTING PUSH BUTTON ASSEMBLY USING UNIVERSAL SPANNER WRENCH (PN 0006983506 NOT SUPPLIED WITH VRK5874 AND VRK5874HF KITS).

\*\* OVERTIGHTENING WILL PRE-ACTUATE VALVE AND CAUSE WEEPAGE, WHILE NOT ENOUGH CONTACT BETWEEN WAVE WASHER AND STEM CAN CAUSE A LOW FLOW CONDITION.



### \*\*\* MODEL VRK5874 & VRK5874HF- VALVE REPAIR KITS INCLUDE THESE ITEMS

#### NOTE!

THIS VALVE IS PRESSURE COMPENSATING. BE SURE TO REMOVE ANY EXISTING FLOW CONTROL DEVICES. (MAY BE PRESENT IN FITTING OR SPUD).

 <b>Haws</b> <sup>®</sup>		1455 KLEPPE LANE SPARKS, NEVADA 89431 (775) 359-4712 FAX (775) 359-7424 E-MAIL: HAWS@HAWSCO.COM WEBSITE: WWW.HAWSCO.COM	
ECN NO. 5945	REVISED PER BY: ECN: 5945 FV	MODEL(S) 5874PB/5874PBF/VRK5874/VRK5874HF/ PBA6/PBA6C/PBA7/PBA7C	PART NUMBER 0002077650.D
DRAWN: FV	DATE: 09/01/23	CHKD.: JC	REVISION 11
APPROVED: FV	DATE: 09/27/23	SCALE: NA	DRAWING TYPE: INSTALLATION
		SIZE: A	SHEET 3 OF 3