



## INSTALLATION, OPERATION & MAINTENANCE INSTRUCTIONS

1455 Kleppe Lane ♦ Sparks, NV 89431-6467 ♦ (775) 359-4712 ♦ Fax (775) 359-7424  
E-mail: [haws@hawsco.com](mailto:haws@hawsco.com) ♦ website: [www.hawsco.com](http://www.hawsco.com)

No. 0510001049 (4)

### Models SP152S/SP152D/SP152SC/SP152DC/SP155PS Proximity Switch Kit

**NOTE TO INSTALLER: Please leave this information with the Maintenance Department.**

#### LIMITED WARRANTY

*HAWS* warrants that all of its products are guaranteed against defective material or poor workmanship for a period of **one year from the date of shipment**. The foregoing notwithstanding, *HAWS* warrants certain specific products or components thereof for an adjusted period. A list of these excepted products and components and a description of their respective warranty terms may be found here: [www.hawsco.com/warranty](http://www.hawsco.com/warranty). *HAWS*' liability under this warranty shall be discharged by furnishing without charge F.O.B. *HAWS* factory any goods, or part thereof, which shall appear to the Company upon inspection to be of defective material or not of first-class workmanship, provided that a claim is made in writing to Company within a reasonable period after receipt of the product. Where claims for defects are made, the defective part or parts shall be delivered to the Company, prepaid, for inspection. *HAWS* shall not be liable for the cost of repairs, alterations or replacements, or the labor required to implement them, or for any expense connected therewith made by the owner or owner's agents, except upon written authority from *HAWS*. *HAWS* shall not be liable for any damages caused by defective materials or poor workmanship, except for replacements, as provided above. Buyer agrees that *HAWS* has made no other warranties either express or implied in addition to those above stated, except that of title with respect to any of the products or equipment sold hereunder and that *HAWS* shall not be liable for general, special, incidental, or consequential damages claimed to arise under the contract of sale.

Equipment manufactured by *HAWS* is warranted to function if installation and maintenance instructions provided are adhered to. The units also must be used for the purpose for which they were intended. Any *HAWS* emergency equipment is intended to supplement first-aid treatment. Due to widely varying conditions, *HAWS* cannot guarantee that the use of this emergency equipment will prevent serious injury or the aggravation of existing or prior injuries.

**EXCEPT AS EXPRESSLY STATED HEREIN, HAWS HEREBY DISCLAIMS ALL WARRANTIES, WHETHER EXPRESS OR IMPLIED, ARISING BY LAW OR OTHERWISE, INCLUDING WITHOUT LIMITATION, ANY IMPLIED WARRANTIES OF MERCHANTABILITY AND FITNESS FOR A PARTICULAR PURPOSE. THIS WARRANTY MAY NOT BE MODIFIED OR EXTENDED WITHOUT THE WRITTEN CONSENT OF HAWS. REMEDIES AND REPLACEMENTS STATED HEREIN ARE EXCLUSIVE. IN NO EVENT SHALL HAWS BE LIABLE FOR ANY SPECIAL, PUNITIVE, CONSEQUENTIAL OR INCIDENTAL DAMAGES TO ANY PERSON INCLUDING BUT NOT LIMITED TO DAMAGES FOR LOSS OF USE OR PROFITS, SUBSTITUTE PRODUCTS OR COSTS, PROPERTY DAMAGE, OR OTHER MONETARY LOSS.**

**SHOULD YOU EXPERIENCE DIFFICULTY WITH THE INSTALLATION OF THIS MODEL PLEASE CALL:**

**TECHNICAL SUPPORT: 1-800-766-5612**  
**FOR CUSTOMER SERVICE: 1-888-640-4297**

## IMPORTANT – PLEASE READ

This proximity switch is magnetically operated and has been designed by the manufacturer to provide a signal when a valve is opened at a given piping location. Brackets and mounting hardware are provided to mount to either the shower, and/or the eye/face wash activation valve(s), or the combination of both of them on Haws units. Single pole double throw (SPDT) and double pole double throw (DPDT) options are provided per the following model number breakdown:

SP152S – Single SPDT proximity switch kit for installing at either shower or eye/face wash.  
SP152D – Single DPDT proximity switch kit for installing at either shower or eye/face wash.  
SP152SC – Double SPDT proximity switch kit for installation at both shower and eye/face wash.  
SP152DC – Double DPDT proximity switch kit for installation at both shower and eye/face wash.  
SP155PS – Custom Factory Install Only

**HARDWARE INSTALLATION:** Installation of kit(s) and electrical wiring of proximity switch(es) to be followed per attached drawings, pages 4-8, which show all Installation possibilities (single and double). **Note: See Haws Model Compatibility Table on page 3, for Haws models that these kits will fit on.** If proximity switches are required for a model not listed in Table, please contact Haws customer service at 1-888-640-4297.

**NOTE: Means for grounding/bonding the product should be present in the end installation.**

Switches are provided with ½” NPT(F) (or (M) for the SP155PS to which conduit raceway should be attached for wires to run in. Provided wires are approximately 6 feet long.

**ELECTRICAL RATING:** 3 AMPS DC, 0-28 VDC / 0-120 VAC, 50/60Hz, 100VA MAXIMUM SOURCE LOAD. AMBIENT TEMPERATURE -40°C (-40°F) TO 60°C (140°F). FOR APPLICATIONS AS INTENDED, THE PRODUCT MUST BE SUPPLIED A MAXIMUM OF 28Vdc, 3A FROM AN APPROVED OR AN ACCESSED POWER SUPPLY.

**HAZARDOUS LOCATIONS INSTALLATION:** Identical to non-hazardous installation. Proximity switches are double hermetically sealed and acceptable for Class 1, Division 1 Groups A, B, C, D, and Class II, Division 1, Groups E, F, G, TYPE 4X as defined in the National Electrical Code and Class I, Zone 2, IIC, IIB, IIA, T4, IP65. ATEX II 3G Ex ic IIC T4 Gc, ATEX II 3D Ex ic IIIC T135°C Dc.

**EQUIPMENT INTENDED FOR USE ONLY IN RESTRICTED ACCESS AREAS.** INSTALLATION IN HAZARDOUS LOCATIONS MUST BE PERFORMED BY QUALIFIED PERSONNEL AND BE IN ACCORDANCE WITH ATEX REQUIREMENTS PER REGULATORY CODES IN THE REGION OF IMPORT.

**TROUBLESHOOTING:** If the proximity switch(es) is/are not activating, or no signal is being provided, please contact Haws Technical Support at 1-800-766-5612

These Proximity Switches are QPS certified as accessories for use in Haws manufactured assemblies.



Switches are CE and ATEX marked as accessories in Haws manufactured assemblies.



**For Haws Model Compatibility and Installation Details, consult this Table.**

<b>Model</b>	<b>Installation Details</b>
7260B-7270B	See page 5; must install switch bracket on customer supply piping.
7260BT-7270BT	
7261-7271	
7324	See page 6.
7360B-7460B	See page 5; must install switch bracket on customer supply piping.
7360BT-7460BT	
7360BTWC	
7361-7461	
7460	
7777	
7778B	
8100	See page 5.
8122	See page 5; must install switch bracket on customer supply piping.
8122HWC	See page 5.
8123	See page 5; must install switch bracket on customer supply piping.
8130	
8133H	
8163	
8169	
8300-8309	See page 5.
8300CRP-8309CRP	
8309WC	
8317	See page 6.
8320-8325	See page 5.
8320CRP	
8330	
8336	
8605WC	

NOTES:

1. APPLY SMALL AMOUNT OF THREAD LOCKER (LOCTITE #222MS - SUPPLIED) TO MALE THREADS, WHERE INDICATED.
  2. APPLY SMALL AMOUNT OF LUBRICANT (DOW CORNING #111 - SUPPLIED) TO PROXIMITY SWITCH (ITEM 1) THREADS, PRIOR TO INSTALLATION (PREVENTS THREAD SEIZING).
  3. THESE PROXIMITY SWITCHES ARE QPS CERTIFIED AS ACCESSORIES FOR USE IN HAWS MANUFACTURED ASSEMBLIES.
- 
4. PROXIMITY SWITCH INSTALLATION LOCATIONS:
    - SINGLE PROXIMITY SWITCH MODELS SP152S AND SP152D CAN BE INSTALLED AT EITHER:
      - A) A SHOWER HEAD ONLY (SEE SHEET 2 OF 5, DETAIL A), OR
      - B) AN EYE/FACE WASH ONLY (SEE SHEET 2 OF 5, DETAIL B AND SHEET 3 OF 5)
    - DOUBLE PROXIMITY SWITCH MODELS SP152SC AND SP152DC CAN BE INSTALLED AT:
      - A) BOTH A SHOWER HEAD AND EYE/FACE WASH ON COMBINATION SAFETY SHOWER UNITS (SEE SHEET 2 OF 5, DETAILS A AND B AND SHEET 3 OF 5).
  5. PROXIMITY SWITCH KIT BRACKETS WILL FIT 1/2" - 1" IPS PIPE SIZES. SEE HAWS MODEL COMPATIBILITY TABLE ON PAGE 3 OF HAWS SP152 SERIES OPERATION AND MAINTENANCE MANUAL, FOR MODELS THAT THESE KITS WILL FIT ON.

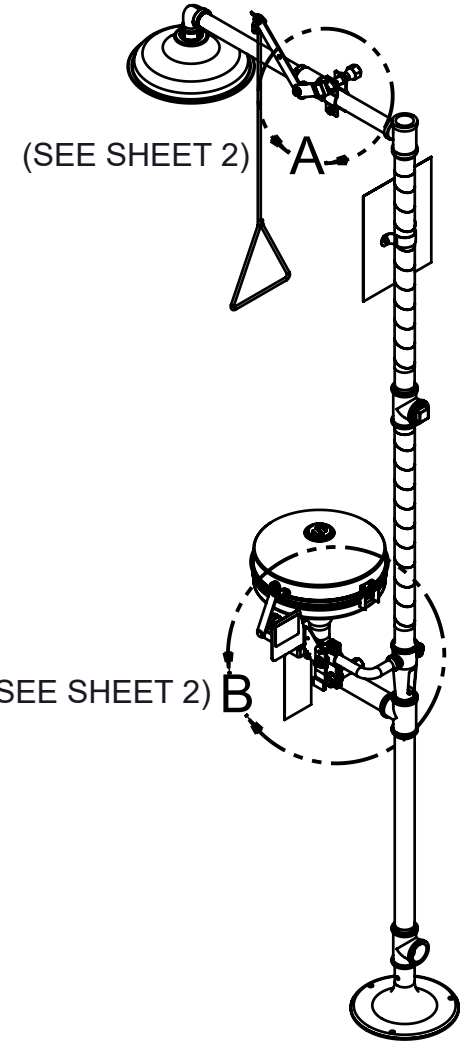

**HAWS 8300-8309  
SHOWN FOR REFERENCE  
(NOT SUPPLIED)**

PARTS BREAKDOWN					
MODEL NUMBER		SP152S	SP152D	SP152SC	SP152DC
ITEM NO.	DESCRIPTION	QTY.	QTY.	QTY.	QTY.
1	PROXIMITY SWITCH, SPDT	1	--	2	--
	PROXIMTY SWITCH, DPDT	--	1	--	2
2	STRAP, PROXIMITY SWITCH	2	2	4	4
3	WASHER, FLAT, 1/4	2	2	4	4
4	NUT, 1/4-20	1	1	2	2
5	SCREW, 1/4-20 X 1-1/4	1	1	2	2
6	JAM NUT, 5/8-18, PROXIMITY SWITCH	2	2	4	4
7	MAGNET, PROXIMITY SWITCH	1	1	2	2
8	NUT, 3/8-24	1	1	1	1
9	WASHER, FLAT, 3/8	2	2	2	2
10	SCREW, 3/8-24 X 1 W/HOLE	1	1	1	1
N/A	LOCTITE THREAD LOCKER 222MS (0003244389)	1	1	1	1
N/A	DOW CORNING LUBRICANT #111 (0003247000)	1	1	1	1

**SEE SHEET 4 OF 5 FOR ELECTRICAL WIRING  
OF PROXIMITY SWITCH(ES)**

		1455 KLEPPE LANE SPARKS, NEVADA 89431 (775) 359-4712 FAX (775) 359-7424 E-MAIL: HAWS@HAWS.CO.COM WEBSITE: WWW.HAWS.CO.COM	
		MODEL(S) SP 152S/SP152D/SP152SC/SP152DC/SP155PS	PART NUMBER 0510001049.D REVISION 4
ECN: 5551 DRAWN: LF APPROVED: FV	REV. EGN: 5973 DATE: 07/30/20 DATE: 11/03/23	BY: FV CHKD: KM	SCALE: 1:16   DRAWING TYPE: INSTALLATION   SIZE: A   SHEET 1 OF 5

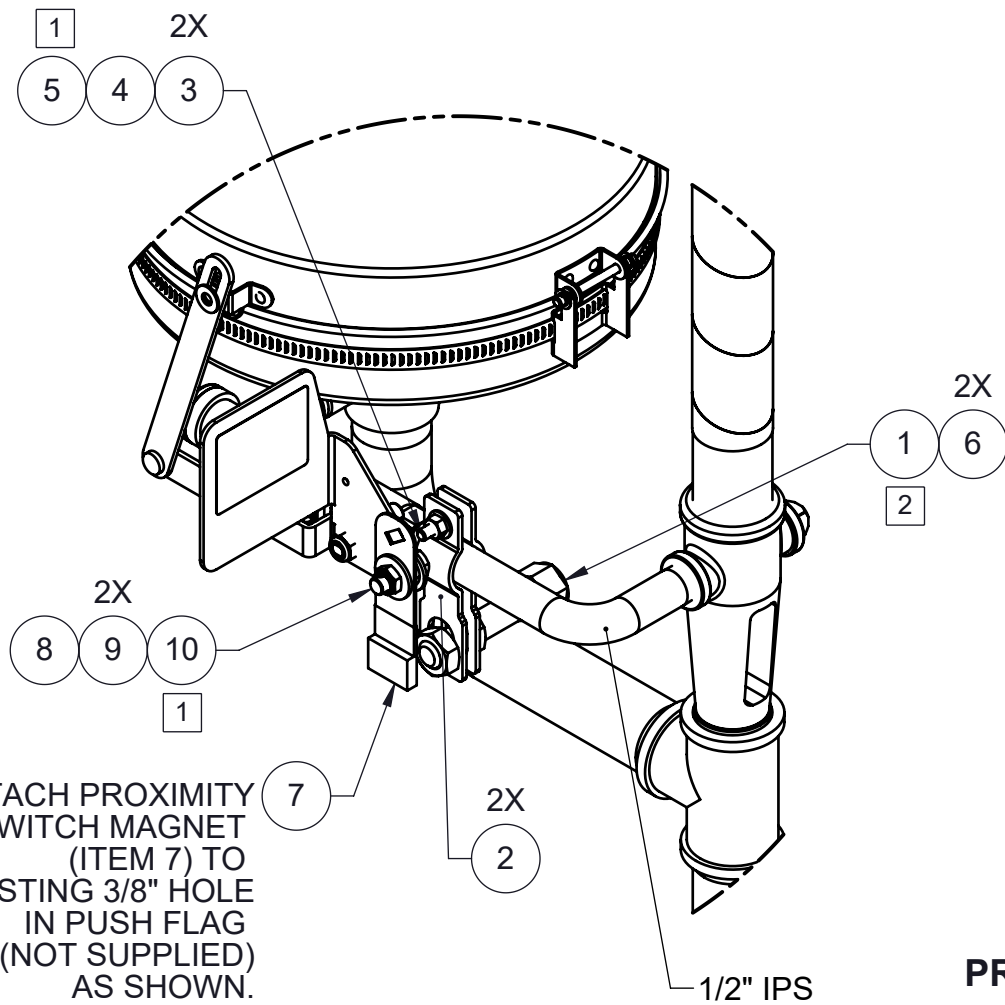

ATTACH PROXIMITY SWITCH MAGNET (ITEM 7) TO EXISTING 3/8" HOLE IN PUSH FLAG (NOT SUPPLIED) AS SHOWN.

**DETAIL B  
(EYE/FACE WASH)**

**SEE SHEET 3 OF 5 (PAGE 6) FOR VERTICAL ORIENTATION OF PROXIMITY SWITCH ON EYE/FACE WASH FOR MODELS 7324 OR 8317.**

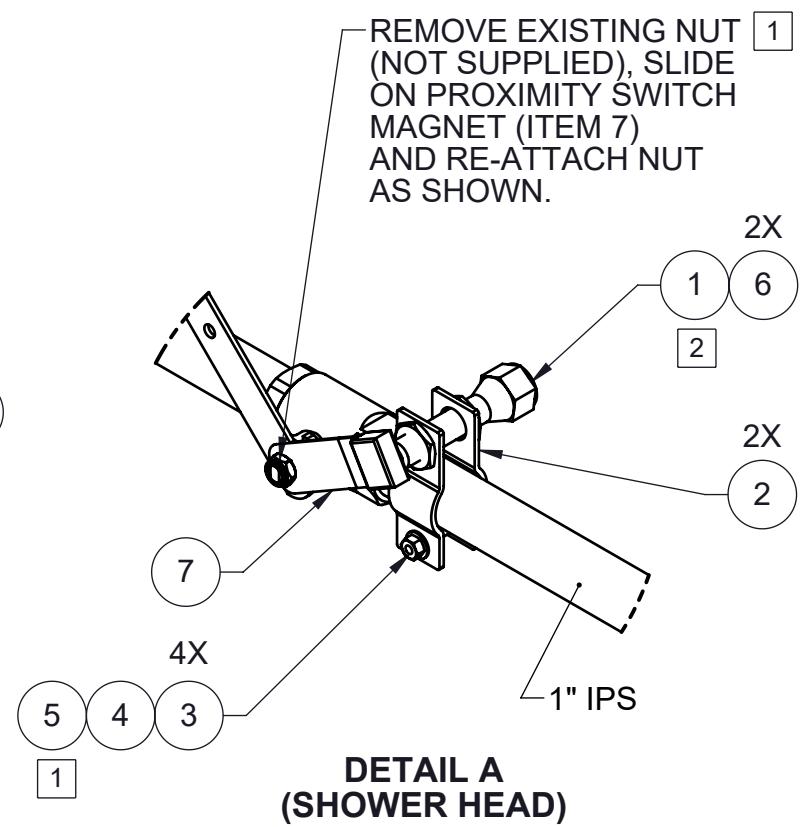

**DETAIL A  
(SHOWER HEAD)**

**PROXIMITY SWITCH LOCATION DETAILS  
(SWITCHES ARE SHOWN ON A COMBO SHOWER FOR REFERENCE. CERTAIN SHOWER/EYEWASH MODELS MAY REQUIRE THAT THE BRACKETS BE MOUNTED TO CUSTOMER SUPPLY PIPING)**

 <b>Haws</b> Since 1906		1455 KLEPPE LANE SPARKS, NEVADA 89431 (775) 359-4712 FAX (775) 359-7424 E-MAIL: HAWS@HAWSO.COM WEBSITE: WWW.HAWSO.COM	
		ECN: 5551 DRAWN: LF APPROVED: FV	REV. EGN: 5973 DATE: 07/30/20 DATE: 11/03/23
			PART NUMBER 0510001049.D REVISION 4
SCALE: 1:20		DRAWING TYPE: INSTALLATION	
SIZE: A		SHEET 2 OF 5	

TO  
EYE/FACE WASH

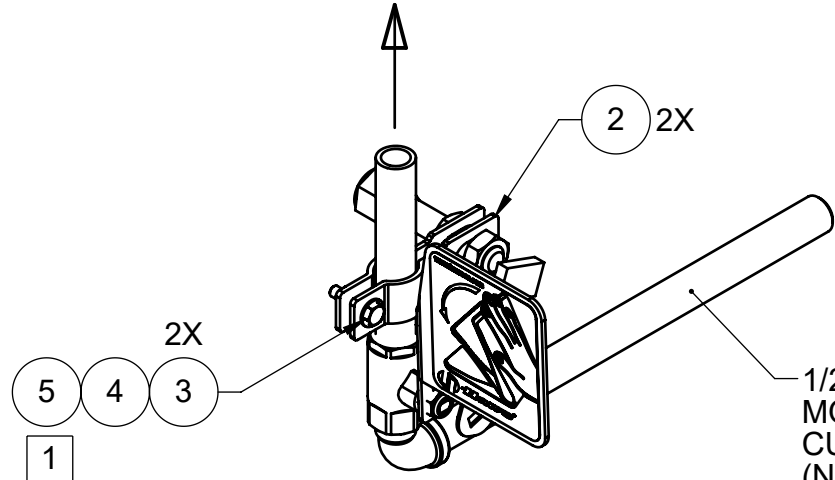

1/2" IPS PIPE ON  
MODEL 8317 OR 1/2" IPS  
CUSTOMER SUPPLY TUBING/PIPE  
(NOT SUPPLIED) ON MODEL 7324.

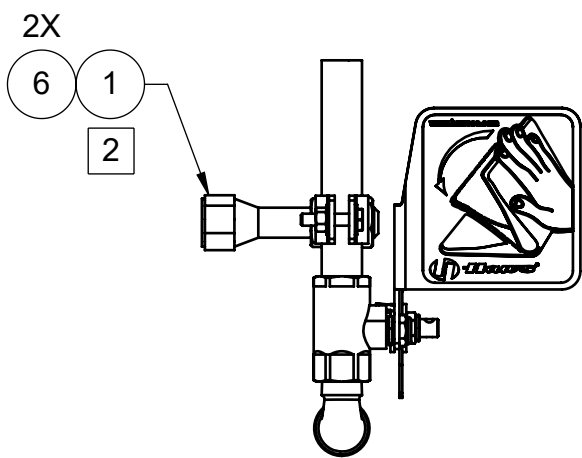

ATTACH PROXIMITY SWITCH  
MAGNET (ITEM 7) TO EXISTING  
3/8" HOLE IN PUSH FLAG  
(NOT SUPPLIED) AS SHOWN.

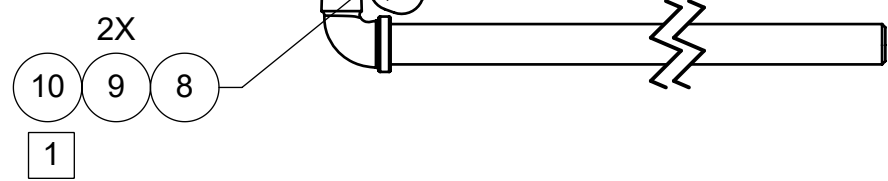

**VERTICAL ORIENTATION  
OF PROXIMITY SWITCH ON EYE/FACE WASH  
FOR MODELS 7324 OR 8317 SHOWN.  
SEE PREVIOUS SHEET (2 OF 5) FOR ALL OTHER INSTALLATIONS.**

 <b>Haws</b> Since 1906		1455 KLEPPE LANE SPARKS, NEVADA 89431 (775) 359-4712 FAX (775) 359-7424 E-MAIL: HAWS@HAWS.CO.COM WEBSITE: WWW.HAWS.CO.COM	
		ECN: 5551 DRAWN: LF APPROVED: FV	REV. ECN: 5973 DATE: 07/30/20 DATE: 11/03/23
			PART NUMBER 0510001049.D REVISION 4
SCALE: 1/4		DRAWING TYPE: INSTALLATION	
SIZE: A		SHEET 3 OF 5	

**ALL ELECTRICAL WORK TO BE DONE PER LOCAL CODE**

PROXIMITY SWITCHES ARE RATED TO 3 AMPS DC,  
VOLTAGE 0-120 VAC or 0-28 VDC, 100VA  
AMBIENT TEMPERATURE -40°C (-40°F) TO 60°C (140°F)

**SP152S**

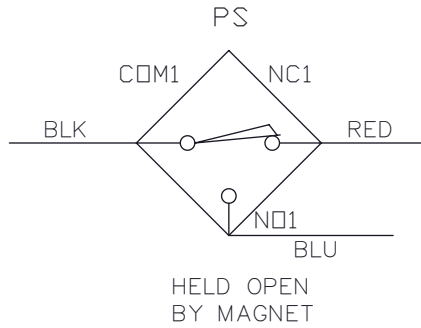

**SP152D**

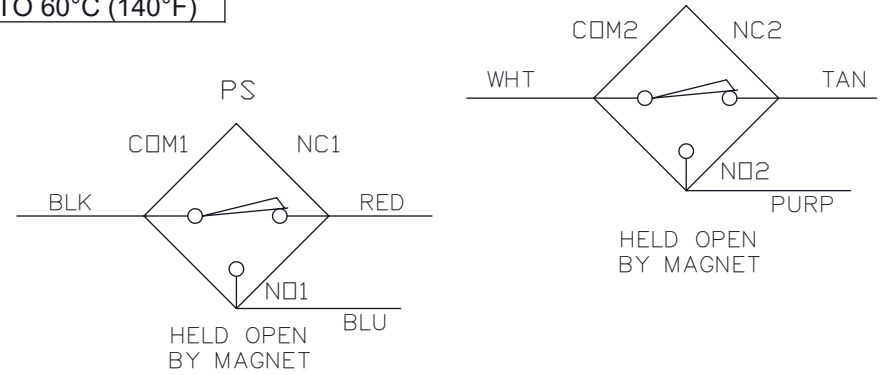

**SP152SC**

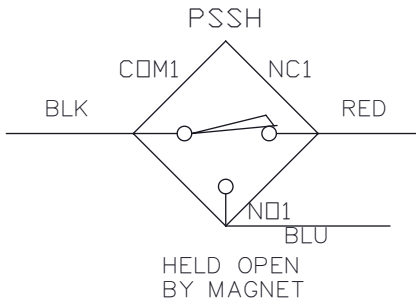

**ELECTRICAL WIRING OF PROXIMITY SWITCH(ES)**

**SP152DC**

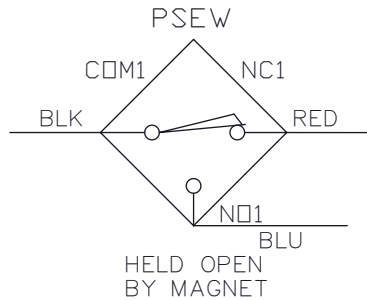
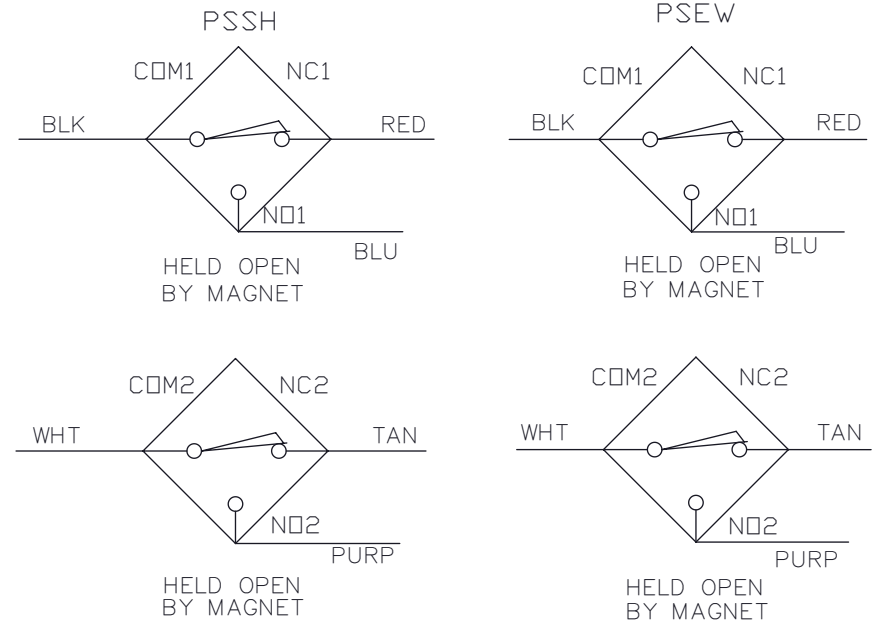

**LEGEND:**

- BLK - BLACK
- BLU - BLUE
- COM - COMMON
- PS - PROXIMITY SWITCH
- PSSH - PROXIMITY SWITCH, SHOWER
- PSEW - PROXIMITY SWITCH, EYEWASH
- PURP - PURPLE
- NO - NORMALLY OPEN
- NC - NORMALLY CLOSED
- WHT - WHITE

		1455 KLEPPE LANE SPARKS, NEVADA 89431 (775) 359-4712 FAX (775) 359-7424 E-MAIL: HAWS@HAWS.CO.COM WEBSITE: WWW.HAWS.CO.COM			
		ECN: 5551 REV. EGN: 5973 LF: 07/30/20 FV: 11/03/23	BY: FV CHKD: KM DATE:	MODEL(S) SP 152S/SP152D/SP152SC/SP152DC/SP155PS	PART NUMBER 0510001049.D REVISION 4
APPROVED:		SCALE: 1:12	DRAWING TYPE: INSTALLATION	SIZE: A	SHEET 4 OF 5

ALL ELECTRICAL INSTALLED PER LOCAL ELECTRICAL CODES.

Proximity Switches rated to 3Amps DC, Voltage 0-28VDC or 0-120VAC 100VA. Ambient Temperature -40° C to +60° C.

WIRING DIAGRAM FOR SP155-PS

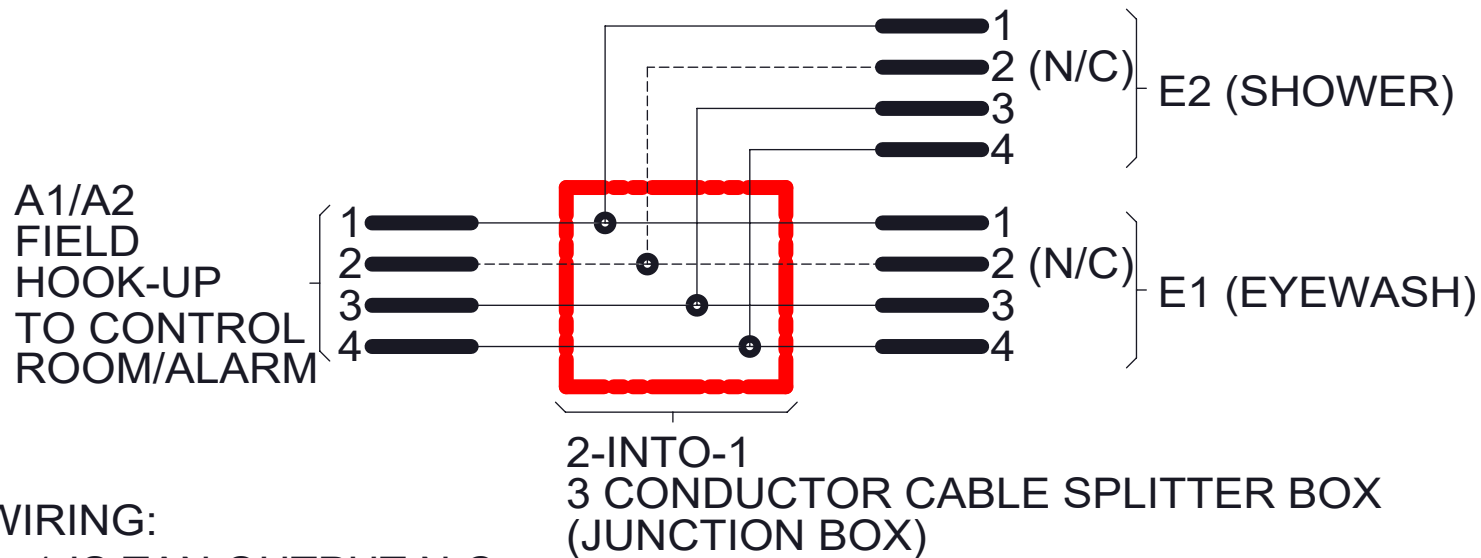

WIRING:

- 1 IS TAN OUTPUT N.C.
- 2 IS WHITE OUTPUT N/C (NOT CONNECTED)
- 3 IS BLUE OUTPUT N.O.
- 4 IS BLACK OUTPUT COMMON

 <b>Haws</b> Since 1906		1455 KLEPPE LANE SPARKS, NEVADA 89431 (775) 359-4712 FAX (775) 359-7424 E-MAIL: HAWS@HAWSO.COM WEBSITE: WWW.HAWSO.COM	
		ECN: 5551 REV. EGN: 5973 DATE: 07/30/20 LF:	BY: FV CHKD.: KM DATE: 11/03/23
APPROVED: FV	DATE: 11/03/23	SCALE: 1:12	DRAWING TYPE: INSTALLATION
		SIZE: A	SHEET 5 OF 5