

**REPLACEMENT INSTRUCTIONS:**

1. **REQUIRED TOOLS:** PHILLIPS SCREWDRIVER (OR 5/16 NUT DRIVER), 1/4" BIT DRIVER, T20 TORX BIT (SUPPLIED), WIDE FLAT-HEAD SCREWDRIVER.
2. DISCONNECT ELECTRICAL POWER TO UNIT.
3. REMOVE THE COOLER SKIRT(S) BY REMOVING 4X SHEETMETAL SCREWS FROM THE BOTTOM OF THE UNIT. UNPLUG POWER CORD FROM WALL .
4. IF A HI-LO UNIT IS INSTALLED, THE HIGH UNIT MAY NEED TO BE REMOVED IN ORDER TO ACCESS THE MOUNTING SCREW ON THE LEFT SIDE OF BOTTLE FILLER. REFER TO DIAGRAM AT RIGHT, AND TO COOLER OPERATION AND MAINTENANCE MANUAL.
5. REMOVE BOTH MOUNTING SCREWS.
6. DISCONNECT BOTTLE FILLER INLET TUBING FROM ELBOW CONNECTOR. REMOVE LOWER PIECE OF TUBING INSULATION.
7. SLIDE BOTTLE FILLER UP AND AWAY FROM UPPER MOUNTING BRACKET UNTIL WIRING HARNESS CONNECTOR IS ACCESSIBLE. DISCONNECT THE WIRING HARNESS.
8. DISCONNECT THE ELECTRICAL CONNECTOR FOR THE LED WIRES.
9. REMOVE 8X SCREWS ON THE BACK OF THE BOTTLE FILLER AND SEPARATE THE DISPLAY FROM THE BOTTLE FILLER. THE DISPLAY IS HELD IN PLACE WITH A STRONG ADHESIVE TAPE, SOME FORCE IS REQUIRED TO SEPARATE IT FROM THE BOTTLE FILLER.
10. REMOVE THE ADHESIVE BACKING FROM THE NEW DISPLAY AND MOUNT IT TO THE BOTTLE FILLER, REVERSING STEPS 4-9.
11. RECONNECT ELECTRICAL POWER TO THE UNIT.
12. RUN THE BOTTLE FILLER TO PURGE AIR FROM THE SYSTEM.

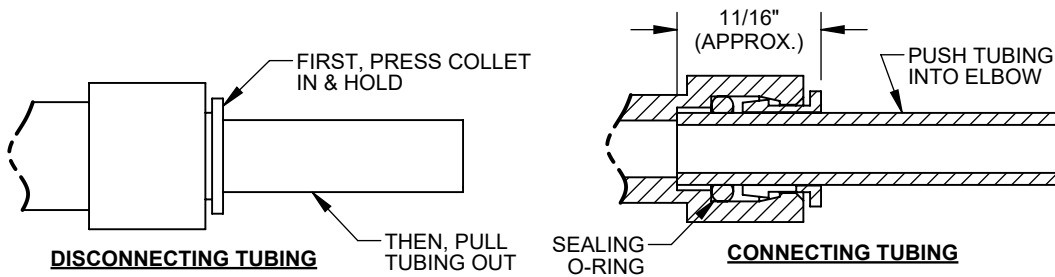

**DISCONNECTING & RE-CONNECTING TUBING**

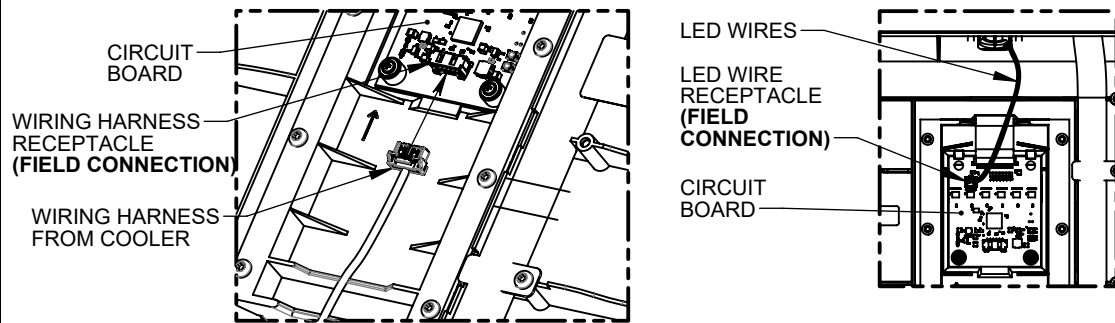

**WIRING HARNESS CONNECTIONS (REAR OF BOTTLE FILLER)**

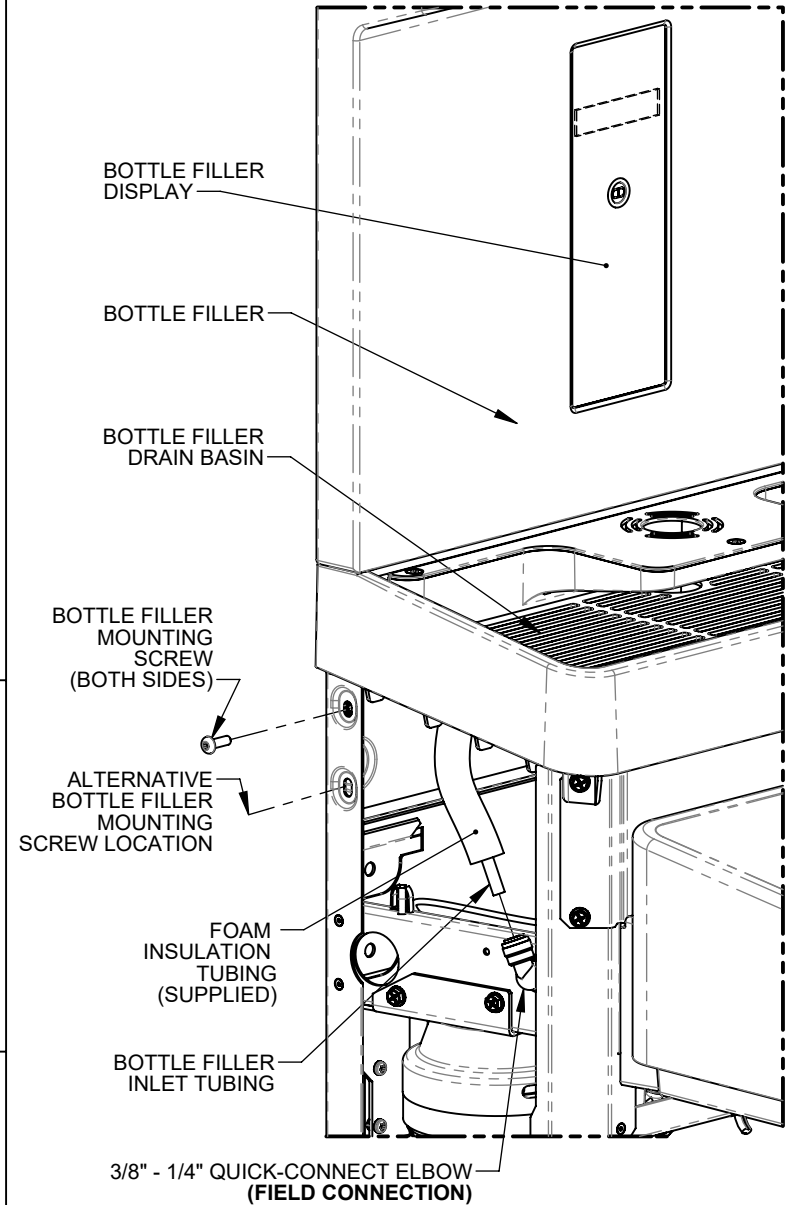

**BOTTLE FILLER MOUNTING & TUBING CONNECTION**



1455 KLEPPE LANE  
 SPARKS, NEVADA 89431  
 (775) 359-4712 FAX (775) 359-7424  
 E-MAIL: HAWS@HAWSO.COM  
 WEBSITE: WWW.HAWSO.COM

ECN: 5883	REV. ECN: 5883	BY: JU	MODEL(S)	PART NUMBER
DRAWN: JL	DATE: 07/25/18	CHKD: JU	1931 - REPLACEMENT 12XX BOTTLE FILLER DISPLAY	0510002149.D
APPROVED: DHP	DATE: 05/11/23	SCALE: 1:2	DRAWING TYPE: INSTALLATION	REVISION: 1
			SIZE: A	SHEET 1 OF 2

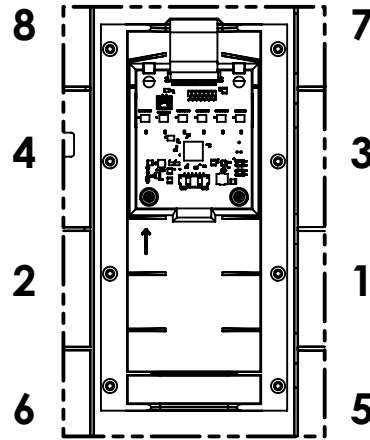
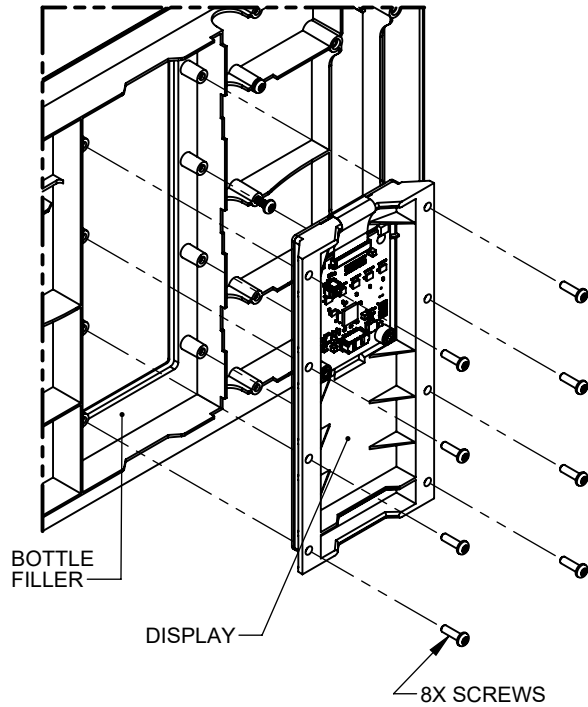

SCREW ORDER FOR REMOVAL AND INSTALLATION

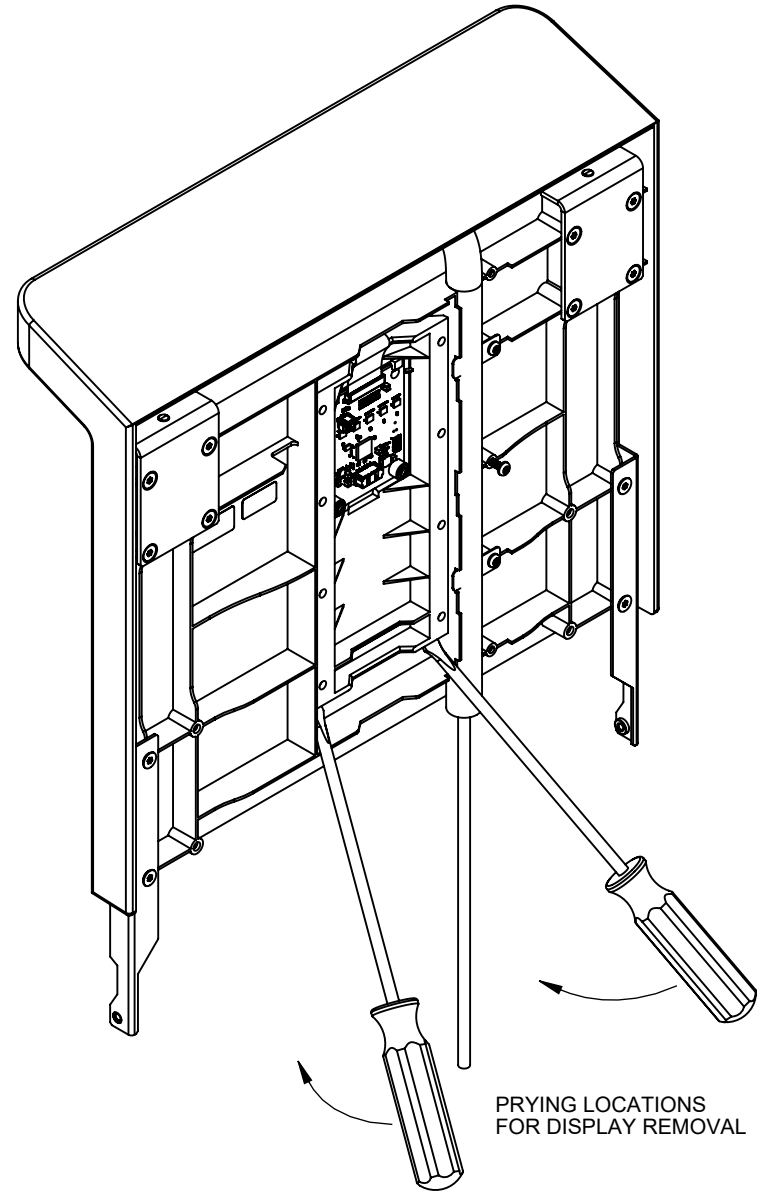

PRYING LOCATIONS FOR DISPLAY REMOVAL

**DISPLAY REMOVAL AND INSTALLATION**  
**(REAR OF BOTTLE FILLER)**

		1455 KLEPPE LANE SPARKS, NEVADA 89431 (775) 359-4712 FAX (775) 359-7424 E-MAIL: HAWS@HAWSO.COM WEBSITE: WWW.HAWSO.COM	
		ECN: 5883 DRAWN: JL APPROVED: DHP	REV. ECN: 5883 DATE: 07/25/18 DATE: 05/11/23
			PART NUMBER 0510002149.D REVISION 1
		SCALE: 1:4 DRAWING TYPE: INSTALLATION SIZE: A	SHEET 2 OF 2