

INSTALLATION:

1. ON AN 1311- OR 1501-SERIES FOUNTAIN, REMOVE THE FOLLOWING:
  - BOTTOM PLATE (NEEDS 1/8" HEX KEY)
  - P-TRAP BEND (NEEDS PIPE WRENCH)
  - 1-5/8" DRAIN STRAINER NUT (NEEDS PIPE WRENCH)
  - STAINLESS STEEL, BRASS, & RUBBER DRAIN WASHERS
  - DRAIN STRAINER
2. PLACE THE EXISTING STAINLESS DRAIN WASHER, THEN THE BOTTLE STAND BASE AS SHOWN, OVER THE STRAINER HOLE. RE-INSERT THE STRAINER, ROTATING IT SO A DRAIN OPENING FACES THE FRONT.
3. REINSTALL THE OTHER DRAIN WASHERS AND THE STRAINER NUT.
4. INSTALL THE BOTTLE STAND PLATFORM WITH THE 4 SUPPLIED FLAT SCREWS (NEEDS 3/32" HEX KEY).
5. REASSEMBLE THE REMAINDER AND CHECK FOR LEAKS.

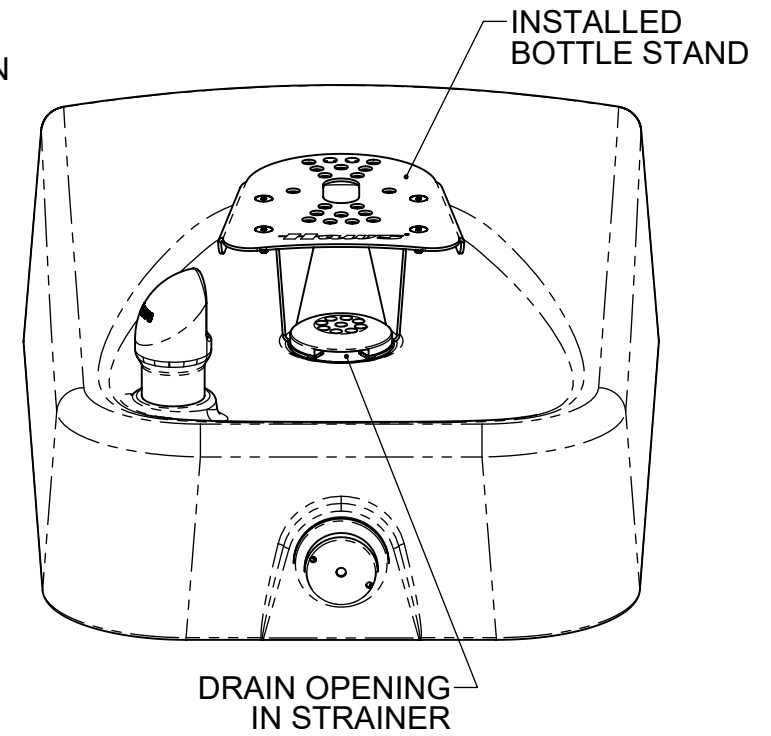
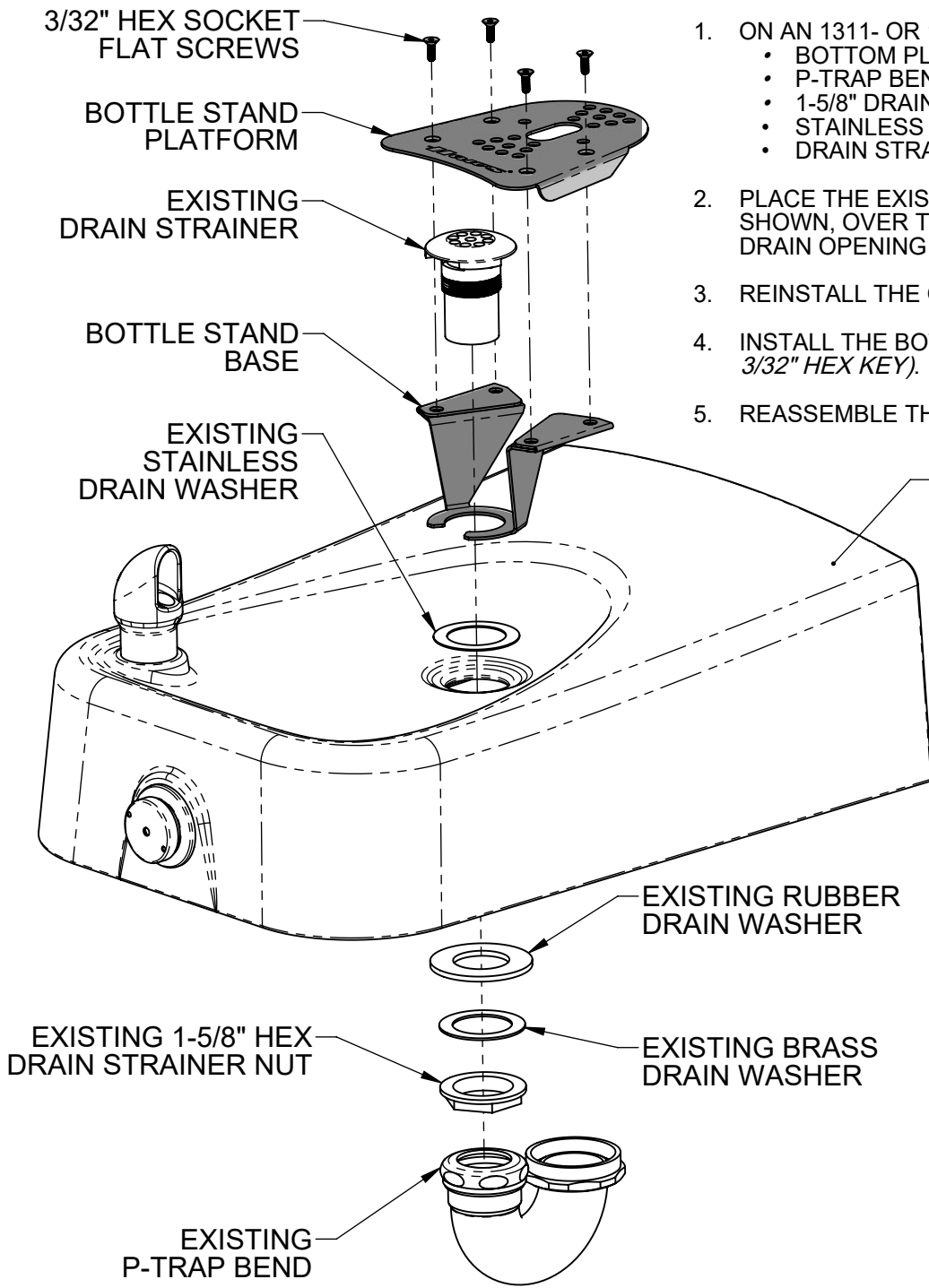

		1455 KLEPPE LANE SPARKS, NEVADA 89431 (775) 359-4712 FAX (775) 359-7424 E-MAIL: HAWS@HAWSO.COM WEBSITE: WWW.HAWSO.COM	
		ECN: 5784 REV. ECN: 5784 BY: JL DATE: 01/27/22 CHKD: JSLP	MODEL(S) BTL1311
DRAWN: JL APPROVED: JL	DATE: 09/29/22	SCALE: 14 DRAWING TYPE: INSTALLATION	REVISION 1 SHEET 1 OF 1