

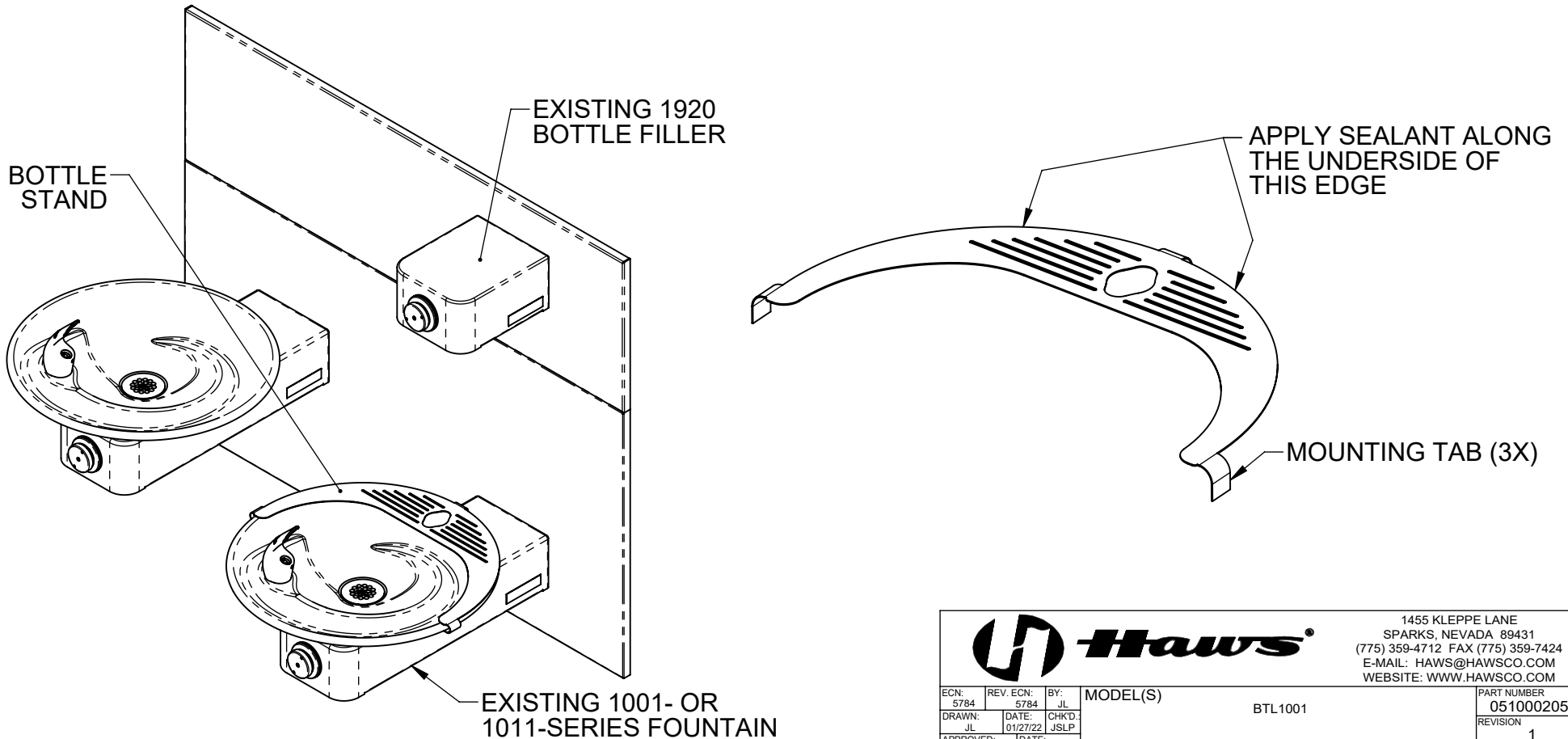

INSTALLATION:

1. BEFORE PLACING THE BOTTLE STAND ONTO AN EXISTING 1001- OR 1011-SERIES FOUNTAIN BOWL:
 - USE PLIERS TO BEND THE 3 BOTTLE STAND MOUNTING TABS INTO A "C" SHAPE.
 - APPLY A SMALL QUANTITY OF SEALANT (PLUMBER'S PUTTY OR SILICONE - NOT SUPPLIED) ALONG THE BACK EDGE OF THE UNDERSIDE OF THE BOTTLE STAND. THIS WILL HELP PREVENT WATER FROM SPLASHING OUTWARD.
2. SLIDE THE BOTTLE STAND ONTO THE BACK OF THE BOWL AS SHOWN, PULLING IT FULLY FORWARD.
3. BEND THE MOUNTING TABS AROUND THE LIP OF THE BOWL TO SECURE THE BOTTLE STAND FIRMLY.
4. WIPE OFF ANY EXCESS SEALANT.



				1455 KLEPPE LANE SPARKS, NEVADA 89431 (775) 359-4712 FAX (775) 359-7424 E-MAIL: HAWS@HAWSO.COM WEBSITE: WWW.HAWSO.COM	
ECN: 5784	REV. ECN: 5784	BY: JL	MODEL(S) BTL1001	PART NUMBER 0510002050	REVISION 1
DRAWN: JL	DATE: 01/27/22	CHKD: JSLP	SCALE: 1:8	DRAWING TYPE: INSTALLATION	SIZE: A
APPROVED: JL	DATE: 09/29/22				SHEET 1 OF 1