

## CASE STUDY

### HYDRATION SOLUTIONS INDUSTRY EXPERTS PREFER

*Alpha Omega*



#### BACKGROUND

Alpha Omega, an experienced mechanical contractor, is no stranger to different manufacturers of drinking fountains, electric water coolers, and bottle fillers. *Haws* hydration products notably stand out simply because they solve many of the problems that make the corresponding projects time consuming, complex, and costly.

#### CHALLENGES

For plumbers, retrofits and new installations of units like standard drinking fountains, electric water coolers, and bottle fillers can pose a number of issues. "Typically, we install whatever is outlined by the mechanical engineer and they don't really care about the brand as long as it fits the spec," says Bill Becker, estimator and project manager at Alpha Omega Mechanical. This approach can cause issues with hydration units in general because accessibility is usually limited, installation is often complex, and the inevitable repairs are typically time consuming. Appropriate product selection is a key success factor to combating unplanned issues.

#### SOLUTIONS

When Alpha Omega is able to make recommendations for specific units, the team prioritizes hydration solutions that factor for these drawbacks, along with considerations for availability, quality, and reliability. That's why hydration solutions from *Haws* are the first choice for Alpha Omega. "We've been doing business with them since the 1980s," says Becker. "I'm a loyal fan and like supporting family businesses."

That kind of repeat business is a direct reflection of a few things. "*Haws* helps eliminate the human error that happens with plumbing fixtures. The company has worked out a lot of the problems plumbers had with installs." The result is greater efficiency with retrofit projects, including no drywall patching – "a huge time savings," says Becker.

The *Haws* Electric Water Cooler series was specifically designed with the installer in mind. Addressing complaints regarding installation challenges saves on money and time allowing the installer to move onto the next phase of the project quickly.

#### RESULTS

After installing different brands on different projects, both Becker and Alpha Omega plumber, Jonathan Marks, recommend *Haws*. They point to the same benefits, including ease of installation and greater efficiency. "The complexity went way down with *Haws*," says Marks. "Accessibility is great, the unit is streamlined, and more room to maneuver for install saved time!"

As a mechanical contractor, Alpha Omega has its own customers to serve. Opting for *Haws* hydration solutions means faster, easier installs and long-term reliability, making for happy plumbers and happier customers.

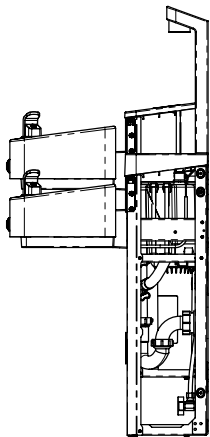
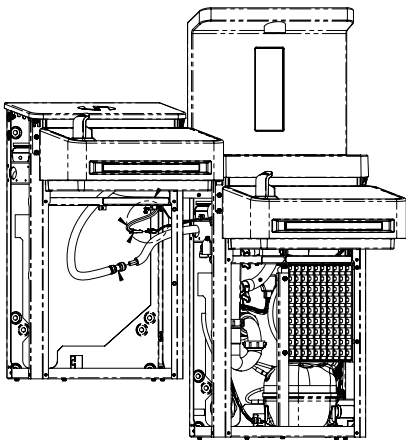

#### FOR MORE INFORMATION

[www.HawSCO.com](http://www.HawSCO.com)

[info@hawSCO.com](mailto:info@hawSCO.com)

888.640.4297