

FEATURES & BENEFITS

OPTIONS

For more information, visit www.hawsco.com or call (888) 640-4297.



SPECIFICATIONS

Model VRKH05 is the sensor valve for the Haws HO (hands-off) fountains, and the 1RKHO, 2RKHO and 3RKHO sensor kits produced after May, 2021.

APPLICATIONS

Haws manufactures drinking fountains, faucets and electric water coolers to be lead-free by all known definitions including NSF/ANSI/CAN 61-Section 9, NSF/ANSI/CAN 372, California Proposition 65, and the Federal Safe Drinking Water Act. Product is compliant to California Health and Safety Code 116875 (AB 1953-2006), and NSF/ANSI/CAN 61: Q ≤ 0.5.

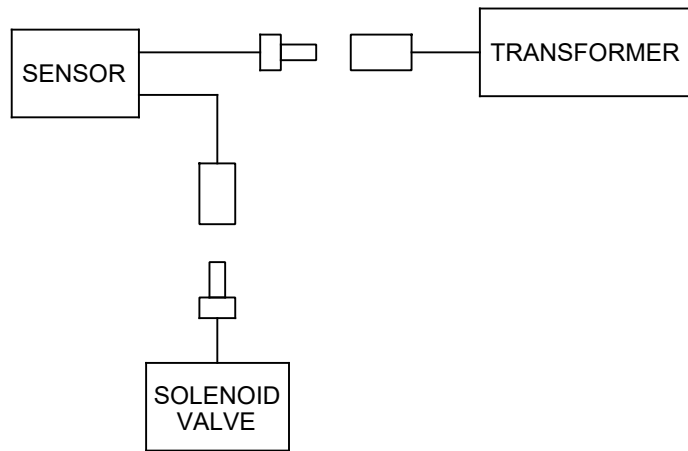

VRKH05 WIRING SCHEMATIC

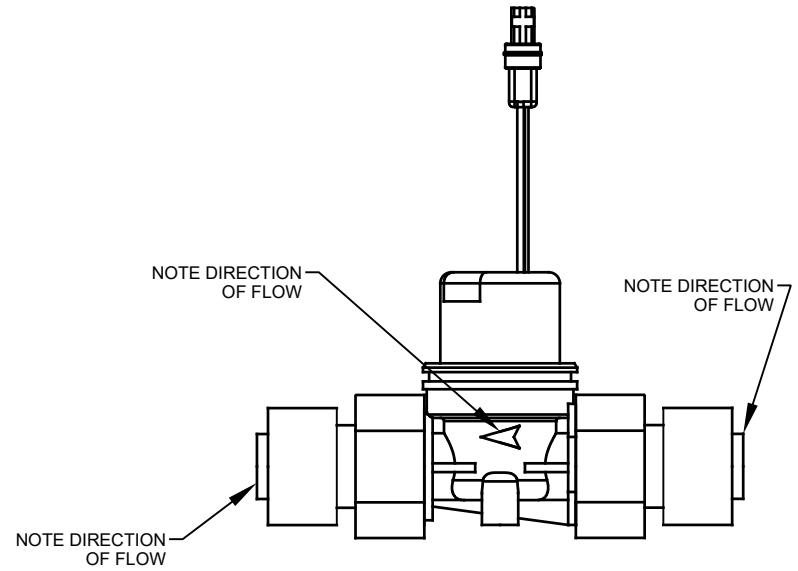

SOLENOID VALVE ASSEMBLY

		Haws [®]		1455 KLEPPE LANE SPARKS, NEVADA 89431 (775) 359-4712 FAX (775) 359-7424 E-MAIL: HAWS@HAWS.CO.COM WEBSITE: WWW.HAWS.CO.COM	
				MODEL(S) VRKH05 SOLENOID VALVE FOR RKHO	
ECN NO. 5649	REVISED PER ECN: 5649	BY: BJM	DATE: 02/11/21	CHK'D: FV	SCALE: N/A
DRAWN: BJM	DATE: 02/11/21	APPROVED: BJM	DATE: 02/22/21	DRAWING TYPE: INSTALLATION	SIZE: A
				SHEET 4 OF 4	