

FEATURES & BENEFITS

ADA COMPLIANCE

ADA-compliant bottle filling station and dual-height high-low drinking fountain required for wheel chair use, and for the standing person.

FRONT APPROACH

Face all three water stations frontward and the overall footprint needed is only 73 inches wide, saving 33% of the hard scape required for access compliance. This also allows the fountain to be placed with its back to within 8 inches of a wall or a fence.

BOTTLE FILLER

The ADA-compliant open design bottle filling station offers a 17" high bottle area, and open sides making this push button operated bottle filling station more accessible to users.

STAINLESS STEEL VALVES

The push-button activated valves offers the only all stainless steel valve body that is machined out of solid bar stock, is fully serviceable through the front of the push button assembly offering access to the water control cartridge and integral water supply strainer, and with front access to the water stream height adjustment for easy maintenance without having to remove the valve. Operating pressure range of 30 to 90 psi (2.1 to 6.2 bar).

BUBBLER HEADS

Polished chrome plated brass bubbler head with integral 5/8" dia. threaded shank for vandal resistant strength, and top-down access for nozzle replacement or water line service, with .45 gpm flow rate.

CONSTRUCTION

Heavy-duty stainless steel with silver powder-coated color finish, and stainless-steel drinking fountain bowls. Modular construction allows for easy replacement or rearrangement of drinking fountain bowls and bottle filler modules.

DRAIN CLEAN-OUT

Top-down access to the drain allows the fountain to be cleaned without taking the unit apart, good for outdoor settings with drain-clogging sand or leaves.

OPTIONS

- Pet Fountain: Model 3670, dog bowl attachment for 3600 series pedestal fountains.
- Hose Bib: Model 3660, lockable hose bib attachment for 3600 series pedestal fountains.
- Installation Aid: Model MTG.3600, mounting guide for 3600 series pedestal fountains.

For more information, visit www.hawsco.com or call (888) 640-4297.



SPECIFICATIONS

Model 3612BFA outdoor, ADA-compliant pedestal mounted bottle filler and high-low drinking fountain shall include a heavy-duty stainless steel pedestal with matte silver powder-coating, bottle filler and fountain mounted on adult wheel chair height arm, push-button operated stainless steel valves with front-accessible cartridge and flow adjustment, polished chrome-plated brass vandal-resistant shielded bubbler heads with integral 5/8" dia. threaded shank and top-down access to renewable nozzles, large-opening bottle filler with quick-fill 1 gpm flow rate, 100% lead-free waterways, polished chrome-plated vandal-resistant waste strainers with top-down clean-out access to the drain, vandal-resistant access plates, integral mounting feet, and 1-1/2" slip waste. In extreme environments related to heat and cold, product(s) must be protected from damage/exposure due to these extreme conditions.

APPLICATIONS

The 3612BFA offers a solution for the changing needs of outdoor settings as well as outdoor wheelchair access, appealing to all users through accessibility and safety. This outdoor fountain is ideal in areas such as parks, schools, and other outdoor areas where hydration facilities are needed. Model meets all current Federal Regulations for the disabled including those in the Americans with Disabilities Act. Haws manufactures drinking fountains, faucets and electric water coolers to be lead-free by all known definitions including NSF/ANSI/CAN 61-Section 9, NSF/ANSI/ CAN 372, California Proposition 65, and the Federal Safe Drinking Water Act. Product is compliant to California Health and Safety Code 116875 (AB 1953-2006), and 116876 (AB 100) "NSF/ANSI/CAN 61: Q ≤ 1".



NOTES:

1. WHEN INSTALLING THIS UNIT, LOCAL, STATE, OR FEDERAL CODES SHOULD BE ADHERED TO. INSTALL A TRAP IN THE WASTE LINE AND A SCREWDRIVER STOP IN THE SUPPLY LINE IF REQUIRED.
2. ARM HEIGHT CAN BE CONFIGURED AS DESIRED, REFER TO SHEET 6 FOR ALTERNATE CONFIGURATIONS.
3. MAXIMUM ADJUSTABLE RANGE IS 15° FROM PARALLEL TO BACK OF WALL.

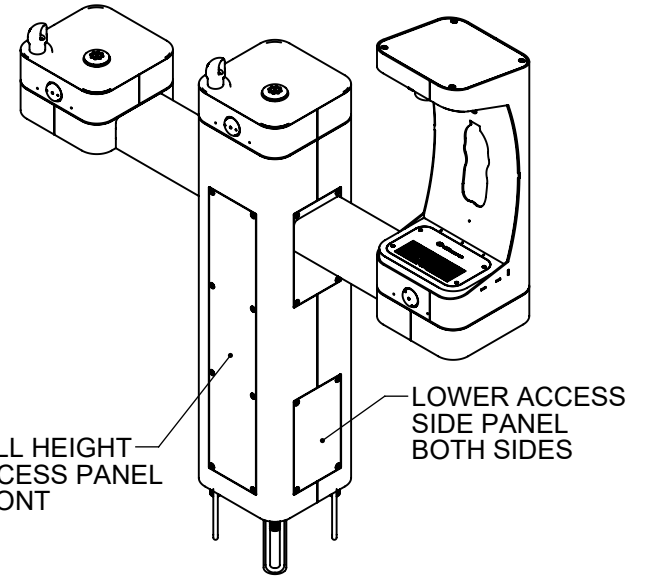
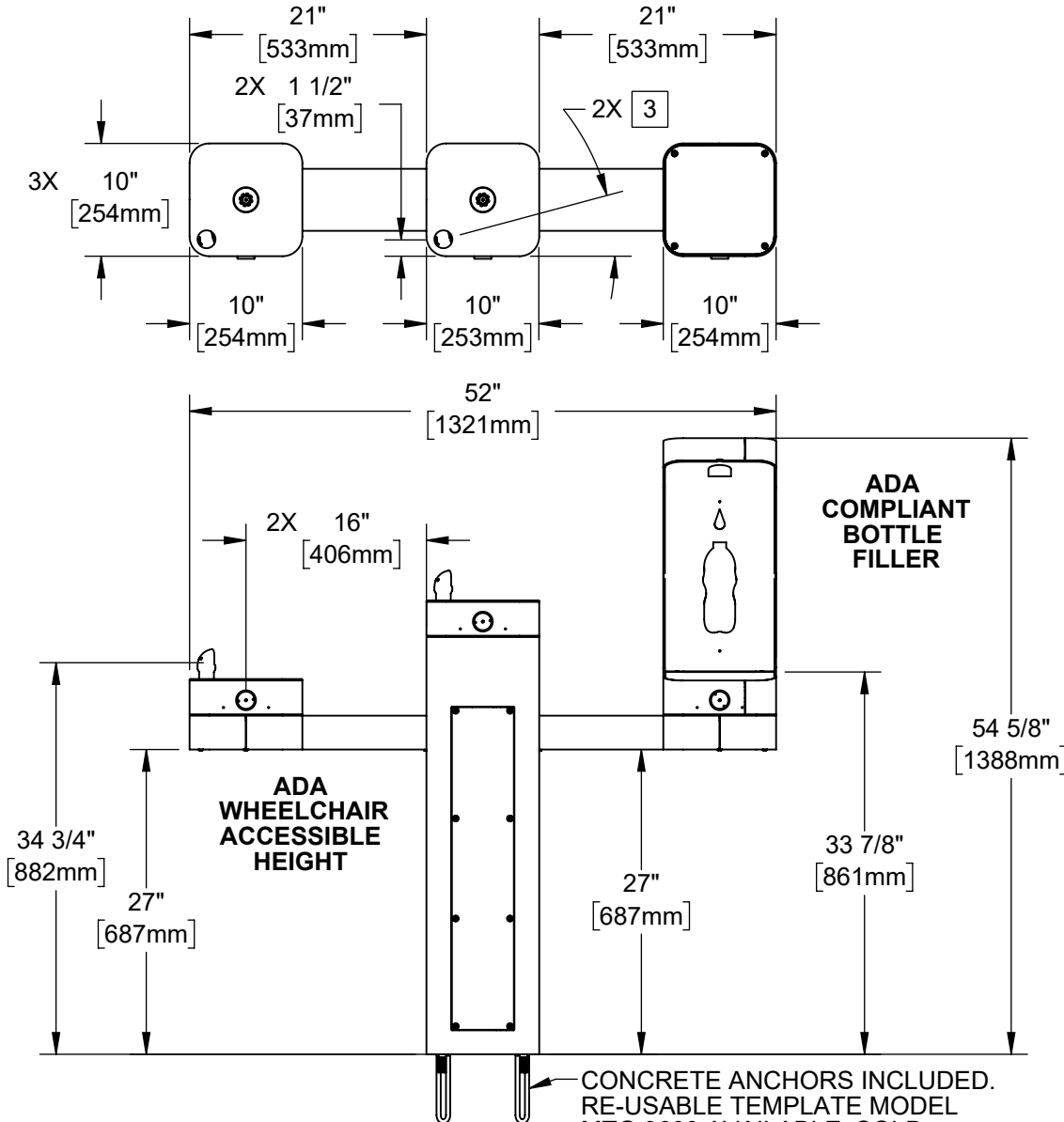

HAWS MODEL 3612BFA/3612FBFA IS FULLY COMPLIANT WITH THE FEDERAL 2010 AMERICANS WITH DISABILITIES ACT (ADA) ACCESSIBILITY REQUIREMENTS WHEN INSTALLED AS SHOWN HERE AND WHEN INSTALLED WITH PROPER CLEARANCES AND ACCESS. IT IS THE RESPONSIBILITY OF THE INSTALLER TO ADHERE TO LOCAL, STATE, AND FEDERAL CODES WHEN INSTALLING THIS UNIT. DISTANCE TO SURROUNDING OBJECTS, APPROACH SURFACES, ETC. SHOULD BE CONSIDERED. REFER TO SHEET 8 FOR MORE INFORMATION.



Haws
Since 1906

1455 KLEPPE LANE
SPARKS, NEVADA 89431
(775) 359-4712 FAX (775) 359-7424
E-MAIL: HAWS@HAWS.CO.COM
WEBSITE: WWW.HAWS.CO.COM

ECN: 5804	REV. ECN: 6030	BY: FV	MODEL(S): 3612BFA & 3612FBFA	PART NUMBER: 0510002056.D
DRAWN: DHP	DATE: 6/11/20	CHKD: JL		REVISION: 3
APPROVED: FV	DATE: 07/02/24	SCALE: 1:16	DRAWING TYPE: INSTALLATION	SHEET 1 OF 8

INSTALLATION INSTRUCTIONS

MODEL MTG.3600

(OPTIONAL)
TEMPLATE FOR
SPACING ANCHORS
DURING CONCRETE
POUR

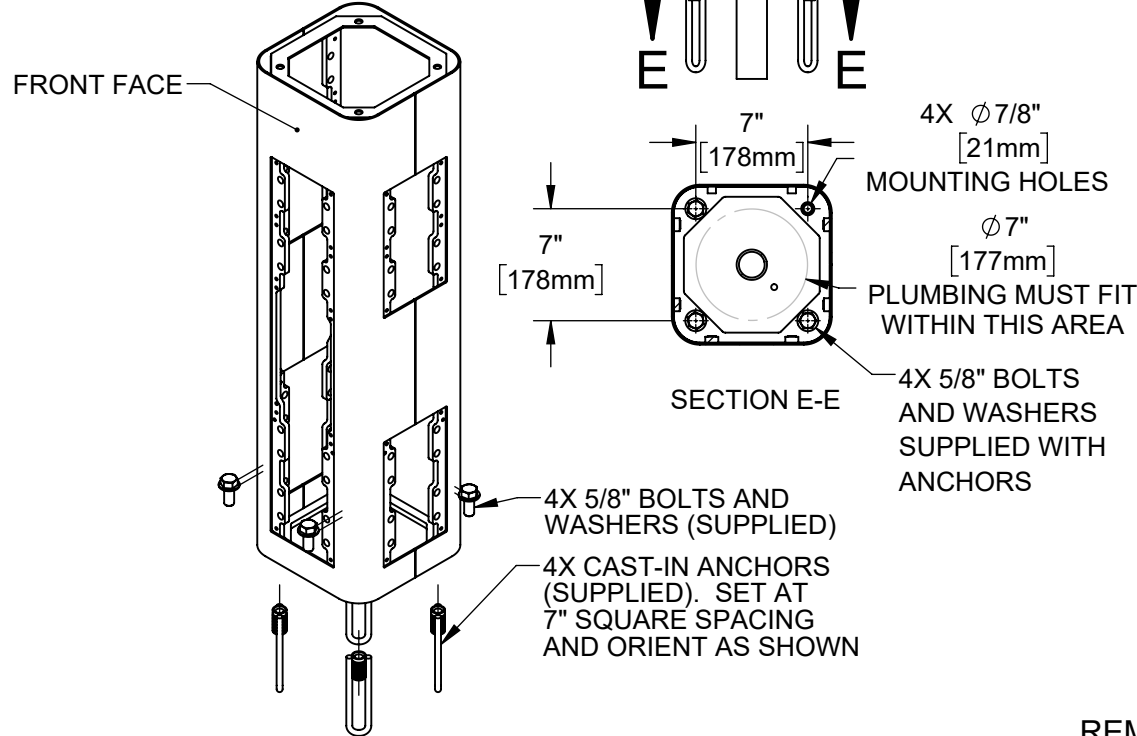
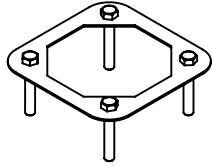

STEP 1

MOUNT PEDESTAL TO CONCRETE SLAB IN DESIRED ORIENTATION. SLAB TO BE 30" MINIMUM SQUARE AND 6" MINIMUM THICK (BY OTHERS). PLUMBING CAST IN CONCRETE MUST FIT IN 7" DIAMETER AREA CENTERED UNDER PEDESTAL LOCATION.

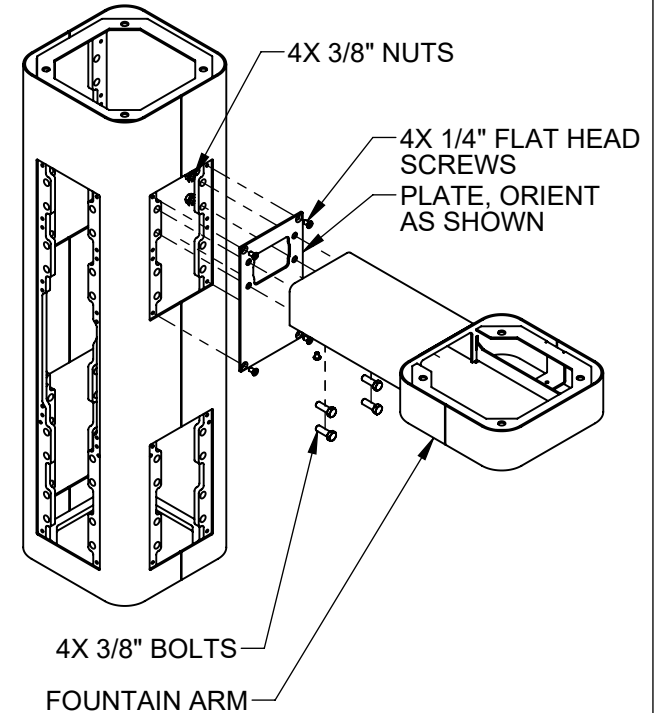

STEP 2

REMOVE BOTTOM COVER PLATES FROM ARMS BY REMOVING 3 1/4" BUTTON HEAD SCREWS. INSTALL ONE ARM ON RIGHT SIDE AS SHOWN. USE 1/4" FLAT HEAD SCREWS (SUPPLIED) TO INSTALL PLATE. USE 3/8" BOLTS AND NUTS (SUPPLIED) AND TORQUE TO 18 FT-LBS TO INSTALL ARM.



1455 KLEPPE LANE
SPARKS, NEVADA 89431
(775) 359-4712 FAX (775) 359-7424
E-MAIL: HAWS@HAWSO.COM
WEBSITE: WWW.HAWSO.COM

ECN: 5804	REV. ECN: 6030	BY: FV	MODEL(S) 3612BFA & 3612FBFA	PART NUMBER 0510002056.D
DRAWN: DHP	DATE: 6/11/20	CHKD: JL		REVISION 3
APPROVED: FV	DATE: 07/02/24	SCALE: 1:12	DRAWING TYPE: INSTALLATION	SIZE: A

INSTALLATION INSTRUCTIONS

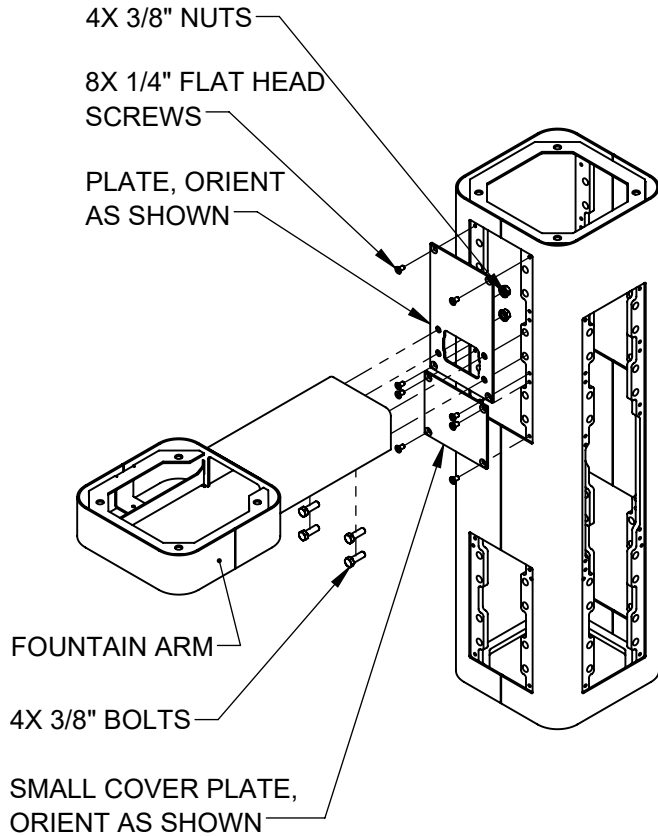

STEP 3
 INSTALL REMAINING ARM ON LEFT SIDE AS SHOWN. USE 1/4" FLAT HEAD SCREWS (SUPPLIED) TO INSTALL PLATES. USE 3/8" BOLTS AND NUTS (SUPPLIED) AND TORQUE TO 18 FT-LBS TO INSTALL ARM.

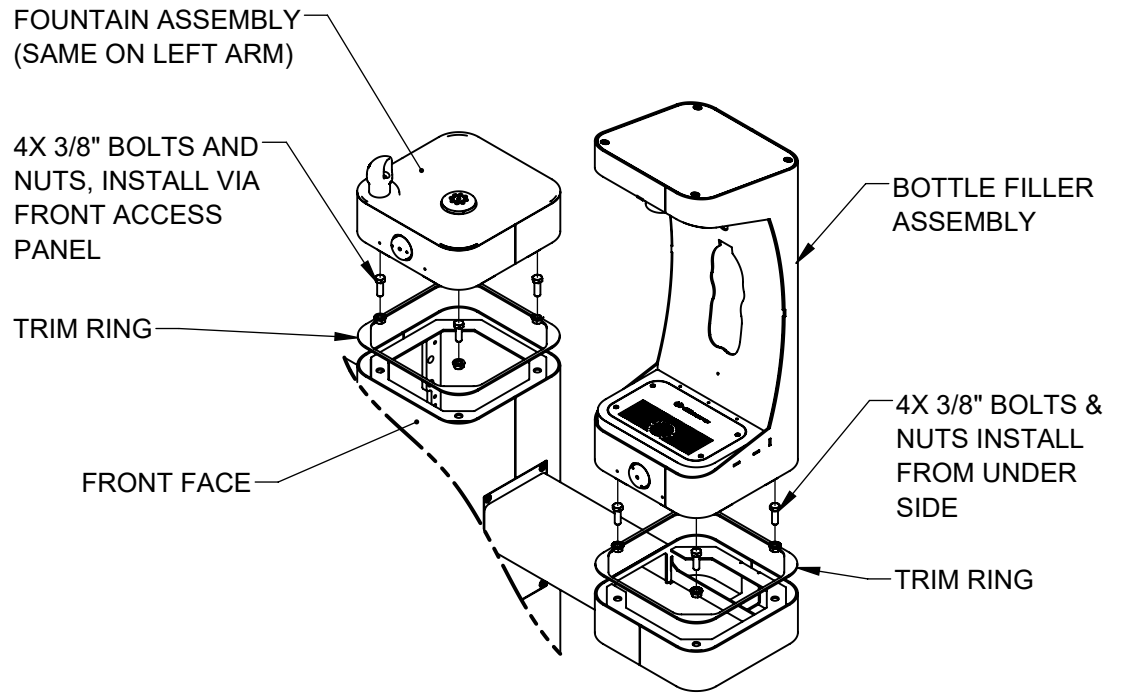

STEP 4
 PLACE SQUARE TRIM RING ON BOTTOM OF BOTTLE FILLER AND PLACE BOTTLE FILLER ON TOP OF EITHER ARM, FACING THE FRONT. USE 3/8" BOLTS AND NUTS TO SECURE BOTTLE FILLER TO THE ARM. PLACE TRIM RING AND INSTALL FOUNTAIN ON PEDESTAL VIA THE FRONT ACCESS PANEL. PLACE TRIM RING AND INSTALL SECOND FOUNTAIN ON REMAINING ARM. CAREFULLY CENTER BOTTLE FILLER, FOUNTAINS, AND TRIM RINGS, THEN TORQUE BOLTS/NUTS TO 18 FT-LBS

		1455 KLEPPE LANE SPARKS, NEVADA 89431 (775) 359-4712 FAX (775) 359-7424 E-MAIL: HAWS@HAWSO.COM WEBSITE: WWW.HAWSO.COM	
		ECN: 5804 DRAWN: DHP APPROVED: FV	REV. ECN: 6030 DATE: 6/11/20 DATE: 07/02/24
PART NUMBER 0510002056.D			REVISION 3
SCALE: 1:12 DRAWING TYPE: INSTALLATION		SIZE: A SHEET 3 OF 8	

INSTALLATION INSTRUCTIONS

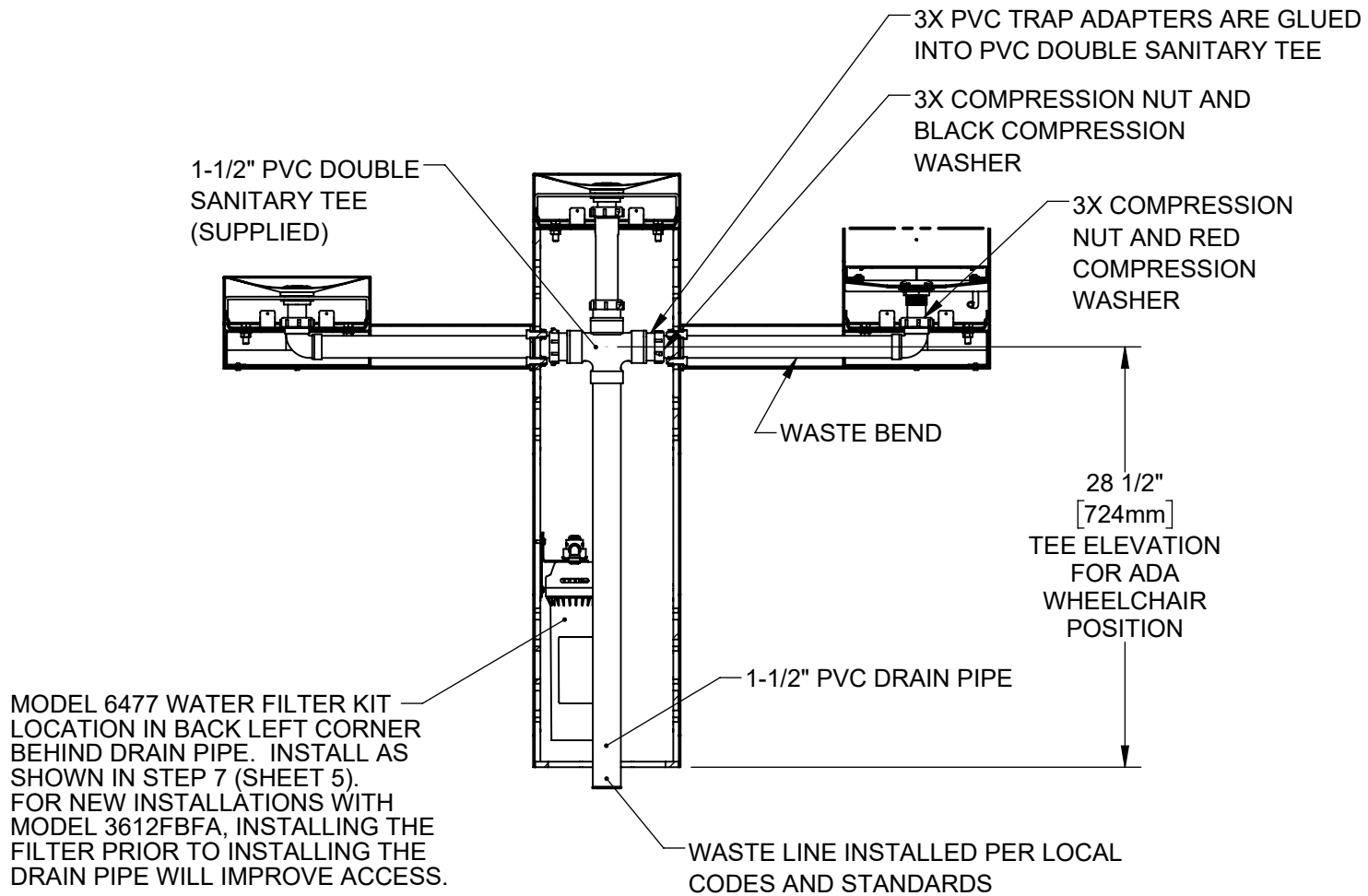

MODEL 3612FBFA (WITH FILTER) SHOWN

STEP 5

INSTALL SUPPLIED DRAIN COMPONENTS AS SHOWN. RED COMPRESSION WASHERS ADAPT FROM 1-1/4" TO 1-1/2" AT EACH DRAIN TAIL PIECE. BLACK COMPRESSION WASHERS ARE USED IN TRAP ADAPTERS AT TEE(S).

USE APPROPRIATE PVC CEMENT TO MAKE SOLVENT CEMENT CONNECTIONS. TRIM WASTE BEND AND/OR TAIL PIECE LENGTH IF REQUIRED. NOTE THAT EXTRA PARTS MAY BE INCLUDED TO FACILITATE OTHER CONFIGURATIONS OF THIS FOUNTAIN.

		1455 KLEPPE LANE SPARKS, NEVADA 89431 (775) 359-4712 FAX (775) 359-7424 E-MAIL: HAWS@HAWS.CO.COM WEBSITE: WWW.HAWS.CO.COM	
		ECN: 5804 DRAWN: DHP APPROVED: FV	REV. ECN: 6030 DATE: 6/11/20 DATE: 07/02/24
PART NUMBER 0510002056.D			REVISION 3
SCALE: 1:12		DRAWING TYPE: INSTALLATION	SHEET 4 OF 8

INSTALLATION INSTRUCTIONS

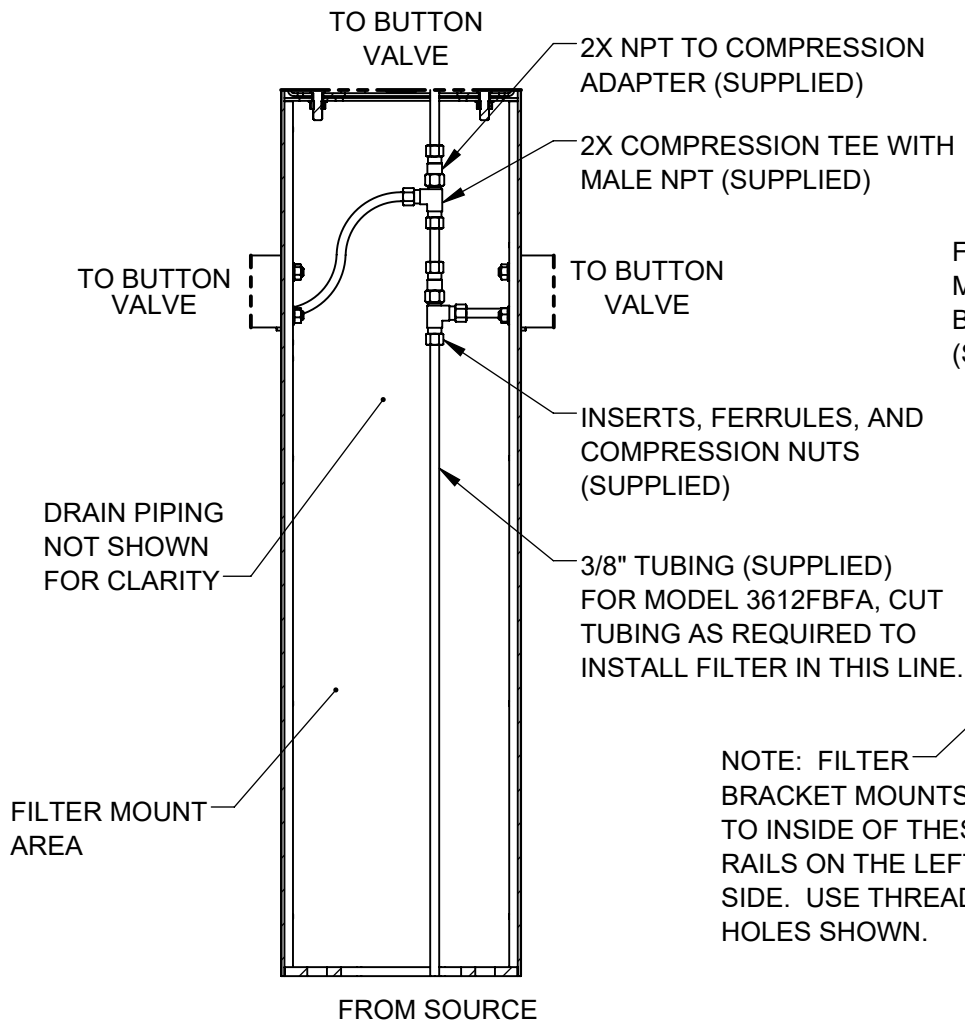

3612BFA SUPPLY PLUMBING

STEP 6

COMPLETE WATER SUPPLY PLUMBING AS SHOWN. OPEN SUPPLY VALVE(S) AND TEST. REPLACE ARM BOTTOM PLATES AND PEDESTAL ACCESS PLATES.

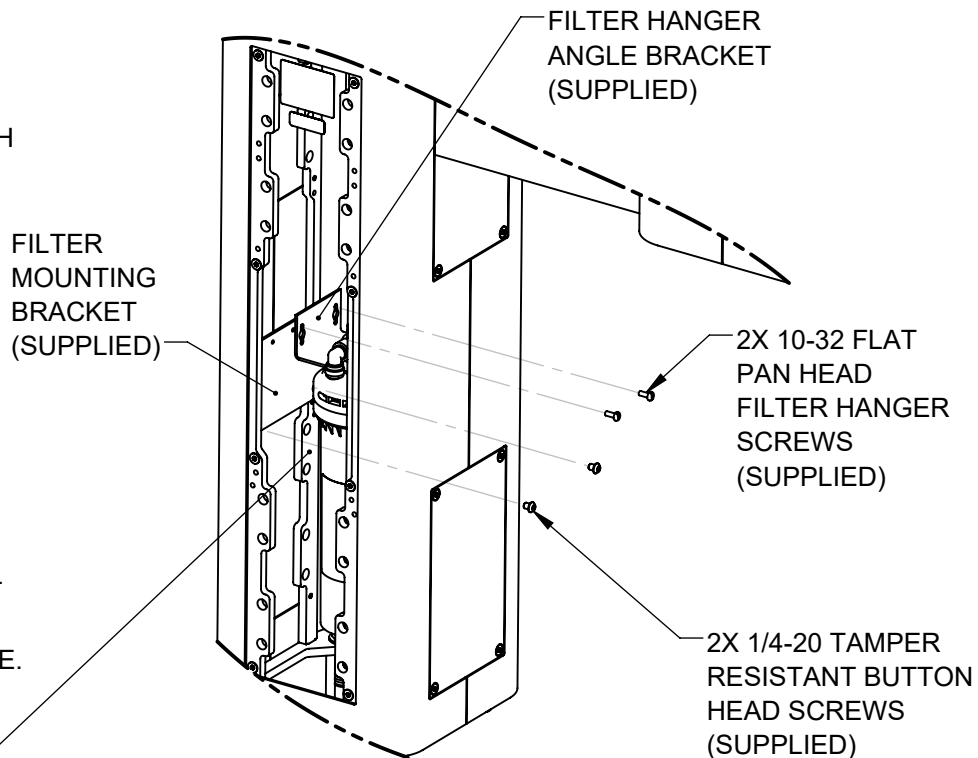

3612FBFA FILTER BRACKET MOUNTING

NOTE: FILTER BRACKET MOUNTS TO INSIDE OF THESE RAILS ON THE LEFT SIDE. USE THREADED HOLES SHOWN.

STEP 5

INSTALL FILTER MOUNTING BRACKET (SUPPLIED WITH MODEL 6477) TO LEFT INSIDE VERTICAL RAILS USING 2 BUTTON HEAD SCREWS AS INDICATED ABOVE. INSTALL FILTER HEAD ON HANGER ANGLE WITH 4 SUPPLIED SELF-TAPPING SCREWS. IF USING THE SUPPLIED 3000-GALLON CAPACITY FILTER, INSTALL FILTER HANGER ANGLE BRACKET IN RIGHTMOST HOLES AS SHOWN. SEE SHEET 6 FOR OWNER-PROVIDED FILTER (6000-GALLON CAP.) INSTALLATION INSTRUCTIONS. SEE MODEL 6477 OPERATION AND MAINTENANCE MANUAL FOR ADDITIONAL DETAILS.

		1455 KLEPPE LANE SPARKS, NEVADA 89431 (775) 359-4712 FAX (775) 359-7424 E-MAIL: HAWS@HAWSO.COM WEBSITE: WWW.HAWSO.COM	
		ECN: 5804 REV. ECN: 6030 DRAWN: DHP APPROVED: FV	BY: FV CHKD: JL DATE: 6/11/20 DATE: 07/02/24
SCALE: 1:8		DRAWING TYPE: INSTALLATION	SIZE: A SHEET 5 OF 8

OPTIONAL OWNER-PROVIDED FILTER INSTALLATION

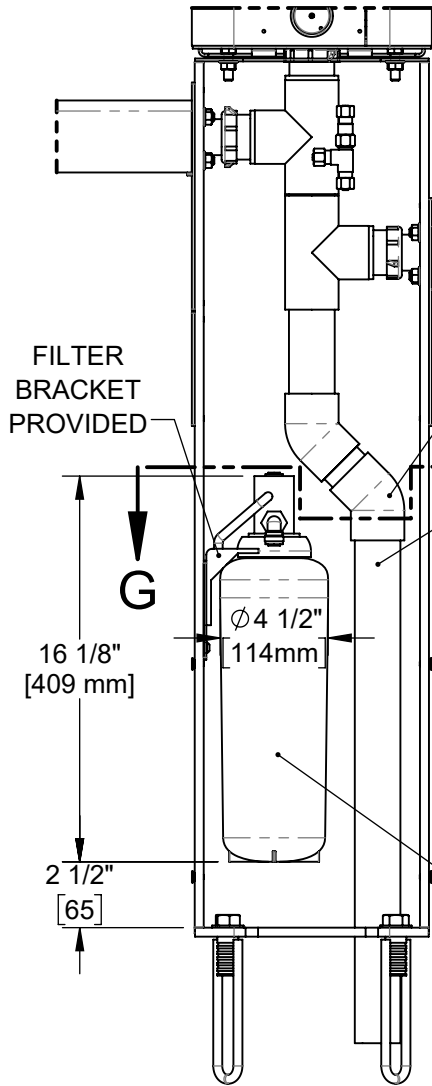

USE SUPPLIED 3" PVC PIPE AND ELBOWS TO ROUTE DRAIN AROUND OPTIONAL CUSTOMER-PROVIDED FILTER.

EXISTING DRAIN PIPE. DRAIN MAY REQUIRE 2" OFFSET LOCATION TO ACCOMMODATE FILTER WITH A LARGER DIAMETER.

*USE 2X SLOTTED 10-32 X 1/2" SCREWS (SUPPLIED) TO MOUNT CUSTOMER-PROVIDED FILTER. USE THREADED HOLES SHOWN

USE 2X TAMPER-RESISTANT 1/4-20 X 5/16 SCREWS (SUPPLIED) TO SECURE MOUNTING BRACKET TO PEDESTAL. USE THREADED HOLES SHOWN.

FOUNTAIN READY TO RECEIVE OPTIONAL OWNER-PROVIDED FILTER RATED UP TO 6000 GALLONS

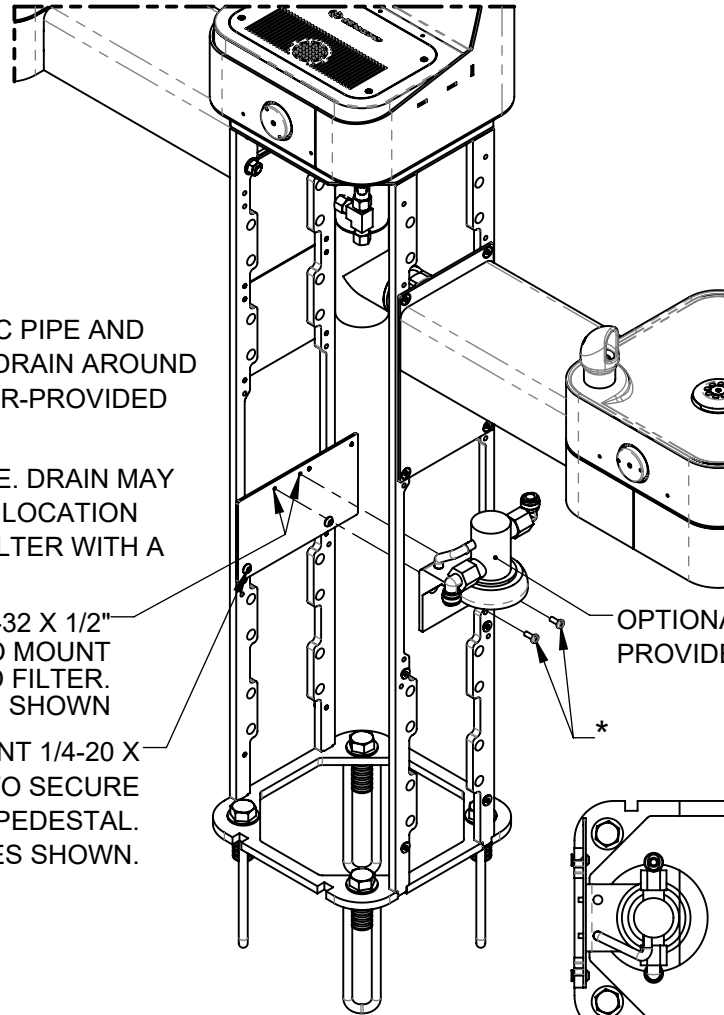

OPTIONAL OWNER-PROVIDED FILTER HEAD

DRAIN OFFSET 2" TO ACCOMMODATE LARGER FILTER MAY BE REQUIRED. CHECK FOR FILTER CLEARANCES BASED ON THE OPTIONAL FILTER YOU PROVIDE, PRIOR TO SETTING DRAIN & ANCHORS.

ALTERNATE DRAIN LOCATION FOR CUSTOMER SUPPLIED OPTIONAL FILTER SECTION A-A

INSTRUCTIONS FOR OPTIONAL OWNER-PROVIDED FILTER

NOTE: MOUNTING BRACKET, 1-1/2" X 3" PVC PIPE AND 45° PVC ELBOWS (QTY. 2) SUPPLIED WITH 6477 FILTER MOUNTING KIT ARE REQUIRED (SHOWN ON MODEL 3612/3612F FOR REFERENCE ONLY). INSTALLATION INSTRUCTIONS APPLY TO EITHER NEW OR RETROFIT APPLICATIONS. SEE SHEETS 4 AND 5 FOR STANDARD FILTER (3000-GALLON CAPACITY) INSTALLATION INSTRUCTIONS.



1455 KLEPPE LANE
SPARKS, NEVADA 89431
(775) 359-4712 FAX (775) 359-7424
E-MAIL: HAWS@HAWS.CO.COM
WEBSITE: WWW.HAWS.CO.COM

ECN: 5804	REV. ECN: 6030	BY: FV	MODEL(S): 3612BFA & 3612FBFA	PART NUMBER: 0510002056.D
DRAWN: DHP	DATE: 6/11/20	CHKD: JL		REVISION: 3
APPROVED: FV	DATE: 07/02/24	SCALE: 1:24	DRAWING TYPE: INSTALLATION	SHEET 6 OF 8

NOTES ON OPTIONAL CONFIGURATIONS

HAWS 3600/3600F SERIES OUTDOOR FOUNTAINS ARE MODULAR AND CAN BE ASSEMBLED AND CONFIGURED MANY DIFFERENT WAYS. DISPLAYED HERE ARE A FEW EXAMPLES. CONFIGURATIONS OTHER THAN THAT SHOWN IN THE INSTALLATION INSTRUCTIONS FOR THE 3612BFA/3612FBFA MAY AFFECT COMPLIANCE WITH ADA REGULATIONS. IT IS THE RESPONSIBILITY OF THE INSTALLER TO UNDERSTAND LOCAL, STATE, AND FEDERAL REGULATIONS AS APPLICABLE IF INSTALLING THIS FOUNTAIN IN CONFIGURATIONS OTHER THAN THAT INDICATED ON SHEET 1 (PAGE 6 OF 13).

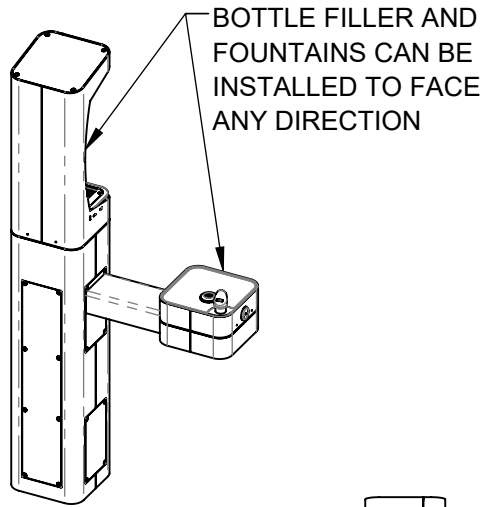

ADA ARM HEIGHT POSITION OPTIONS				
	LEFT SIDE*	RIGHT SIDE*	ARM HEIGHT (LOWER EDGE)	BUBBLER NOZZLE HEIGHT
STANDING ADA	YES (STD)	NO	31-7/8 [809 mm]	39-3/8 [999 mm]**
WHEELCHAIR ADA	YES	YES (STD)	27 [687 mm]	34-5/8 [878 mm]
CHILD ADA	YES	YES	22-1/4 [566 mm]	29-7/8 [757 mm]

* RIGHT AND LEFT CAN BE REVERSED IF PEDESTAL IS ROTATED 180°.

**NOZZLE HEIGHT IS 41-1/2" WHEN FOUNTAIN IS INSTALLED ON TOP OF PEDESTAL.

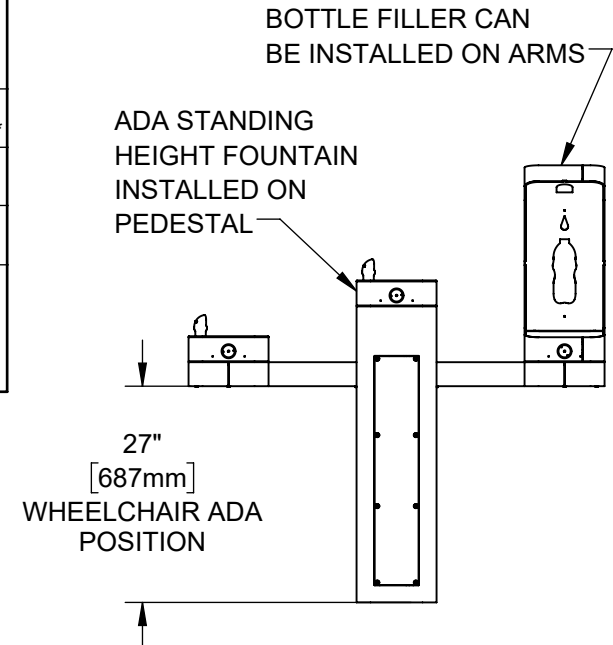
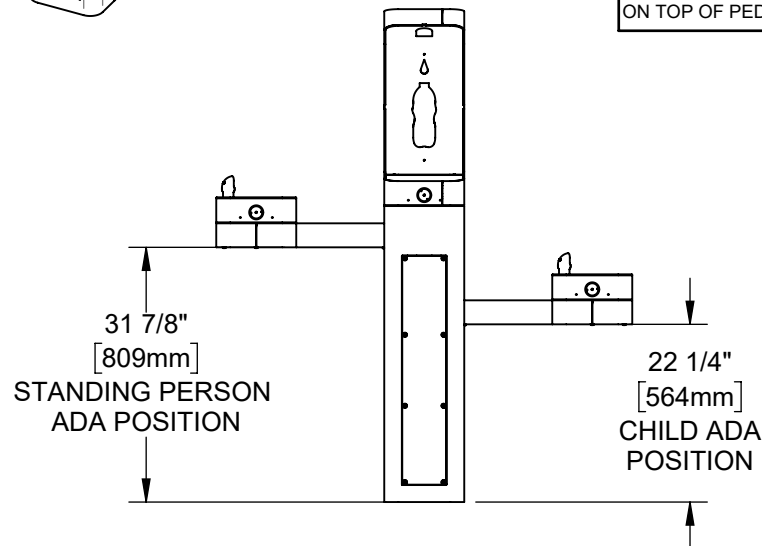



Haws
Since 1906

1455 KLEPPE LANE
SPARKS, NEVADA 89431
(775) 359-4712 FAX (775) 359-7424
E-MAIL: HAWS@HAWSO.COM
WEBSITE: WWW.HAWSO.COM

ECN: 5804	REV. ECN: 6030	BY: FV	MODEL(S): 3612BFA & 3612FBFA	PART NUMBER: 0510002056.D
DRAWN: DHP	DATE: 6/11/20	CHKD: JL		REVISION: 3
APPROVED: FV	DATE: 07/02/24	SCALE: 1:24	DRAWING TYPE: INSTALLATION	SIZE: A SHEET 7 OF 8

NOTES:

4. CLEAR FLOOR SPACES APPLY FOR ALL MODELS WITH A DRINKING FOUNTAIN OR BOTTLE FILLER INSTALLED AT ADA WHEELCHAIR ACCESSIBLE HEIGHT AND PEDESTAL MOUNTED BOTTLE FILLERS.
5. ORIENTATION OF CLEAR FLOOR SPACE IS DEPENDENT ON THE FOUNTAIN OR BOTTLE FILLER ORIENTATION.
6. SOME CALIFORNIA JURISDICTIONS MAY REQUIRE 18" MIN.
7. SOME CALIFORNIA JURISDICTIONS MAY REQUIRE 32" MIN.
8. REFER TO ADA STANDARDS AND/OR YOUR LOCAL BUILDING CODE FOR CLEAR SPACE GUIDELINES FOR PARALLEL APPROACH.

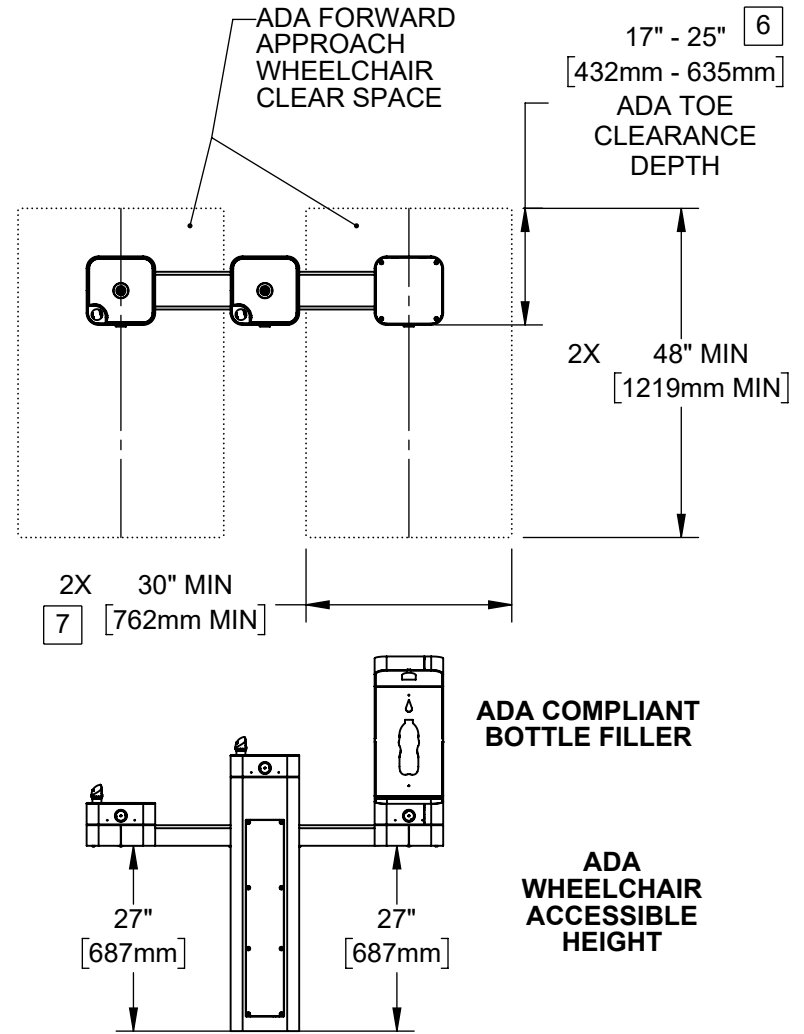
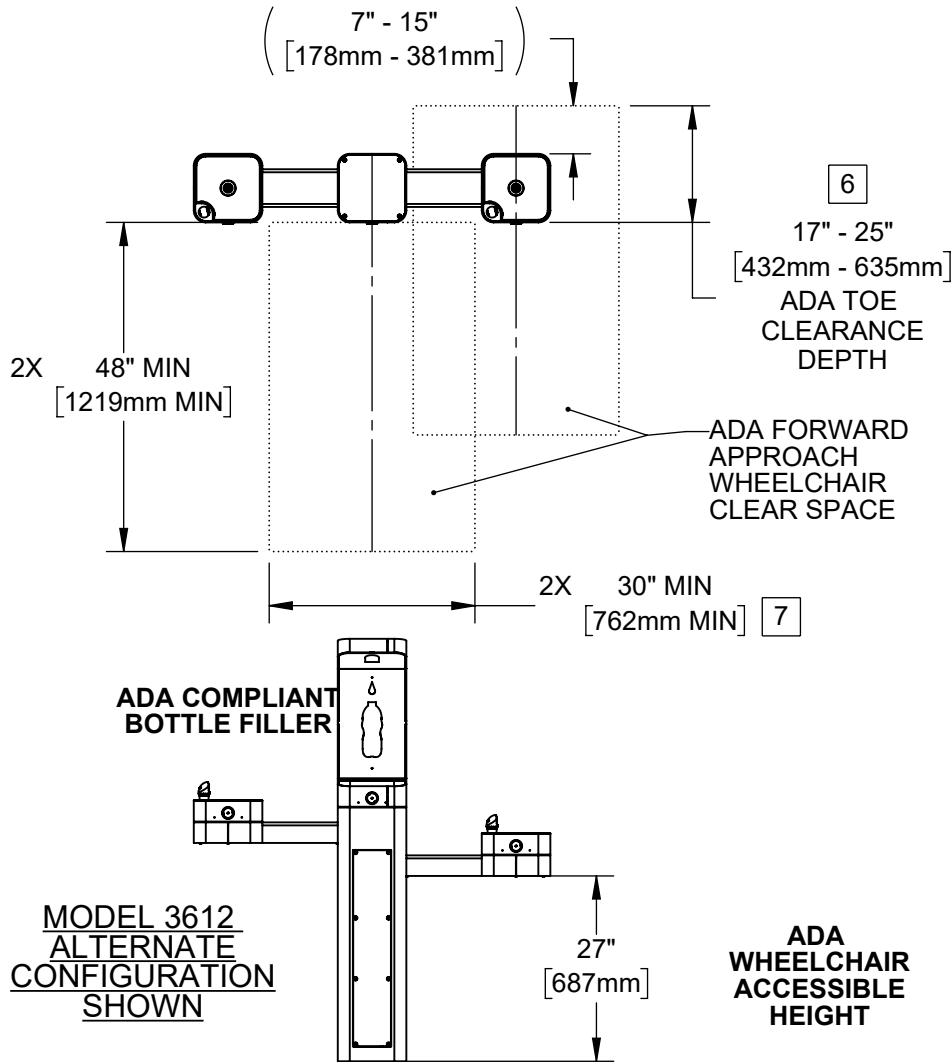

MODEL 3612BFA CONFIGURATION SHOWN

THESE HAWS MODELS ARE FULLY COMPLIANT WITH THE FEDERAL 2010 AMERICANS WITH DISABILITIES ACT (ADA) ACCESSIBILITY REQUIREMENTS WHEN INSTALLED AS SHOWN HERE AND WHEN INSTALLED WITH PROPER CLEARANCES AND ACCESS. IT IS THE RESPONSIBILITY OF THE INSTALLER TO ADHERE TO LOCAL, STATE, AND FEDERAL CODES WHEN INSTALLING THIS UNIT. DISTANCE TO SURROUNDING OBJECTS, APPROACH SURFACES, ETC. SHOULD BE CONSIDERED.

ECN: 5804		REV. ECN: 6030	BY: FV	MODEL(S)	1455 KLEPPE LANE SPARKS, NEVADA 89431 (775) 359-4712 FAX (775) 359-7424 E-MAIL: HAWS@HAWSO.COM WEBSITE: WWW.HAWSO.COM
DRAWN: DHP	DATE: 6/11/20	CHKD: JL		3612BFA & 3612FBFA	PART NUMBER 0510002056.D
APPROVED: FV	DATE: 07/02/24				REVISION 3
SCALE: 1:28		DRAWING TYPE: INSTALLATION		SIZE: A	SHEET 8 OF 8