

FEATURES & BENEFITS

CONSTRUCTION

One-piece stamped basin with low-profile design made of 14-gauge Type 304 stainless steel with integral 1/4" (.6 cm) mounting plate, and vandal-resistant bottom plate. Satin finish resists stains and corrosion.

BOTTLE FILLER

14-gauge Type 304 stainless steel bottle filler housing with touchless operation and 1 gpm (3.78 L) laminar flow with 30-second obstruction time-out.

VANDAL RESISTANT

The bubbler head, sensor, drain strainer and bottom plate are locked in place, discouraging unwanted vandal tampering, and 30-second obstruction time-out to reduce tampering of sensor.

BUBBLER HEAD

Polished chrome-plated brass bubbler head with integral 11/16" dia. basin shank and stainless anti-rotation roll pin for vandal resistance strength. Shielded, angled stream opening provides a steady, sanitary source of drinking water at .45 gpm.

FOUNTAIN VALVES

Bottle filler incorporates a touchless sensor operated stainless steel solenoid valve controlled by a transformer, and a push-button activated valve which offers the only all stainless-steel valve body that is machined out of solid bar stock and is fully serviceable through the front of the push button assembly offering access to the water control cartridge and integral water supply strainer on the fountain.

ACCESS

Low-profile designed bowl and integral trap allow for knee clearance for adult or child ADA access (when installed at appropriate heights).

OPTIONS

- Water Filter: Model 6480 filter kit with 3000 gallon carbon block filter, filter head, and mounting bracket.
- Back Panel: Model BP15C, one-piece panel for fountain/bottle filler combination when child-height ADA requirements are needed.
- Mounting Plate: Model 6700, in-wall mounting plate for model 1920HO and/or model 1107L.
- Mounting Plate: Model 6700R, on-wall mounting plate for model 1920HO.
- Support Frame: Model 6800 In-wall floor mounted fixture support legs, welded steel 4-bolt floor flanges, and supplied with 'U' bolts and hardware.
- Bottle Filler Stand: Model BTL1107, add-on stainless steel stand to place bottle on when 1920 bottle filler is used.

For more information, visit www.hawsco.com or call (888) 640-4297.



SPECIFICATIONS

1107L / BP7 / 1920HO / BP15

Order these items to make up the Model 1107L-1920HO fountain with stainless steel back panel, bottle filler with stainless steel back plate.

FOR INDOOR USE ONLY

APPLICATIONS

Model 1107L-1920HO wall-mounted vandal-resistant ADA drinking fountain and motion activated bottle filler shall include a 14-gauge Type 304 Stainless Steel satin-finish basin with integral 1/4" stainless steel mounting plate, 14 gauge bottle filler bracket, touchless sensor operated solenoid valve with 30-second obstruction time-out on the bottle filler, and vandal-resistant push-button operated stainless-steel valve with front-accessible cartridge and flow adjustment on the fountain, 100% lead-free waterways, polished chrome plated brass vandal-resistant bubbler head, 1 gpm (3.78 L) laminar flow bottle filler, polished chrome-plated brass vandal-resistant waste strainer, vandal-resistant bottom plates, and 1-1/4" NPT integral trap. Unit can be mounted to meet ADA or Child ADA specifications. Manufactured to be lead-free by all known definitions including NSF/ANSI/CAN 61-Section 9, NSF/ANSI/ CAN 372, California Proposition 65, and the Federal Safe Drinking Water Act. Product is compliant to California Health and Safety Code 116875 (AB 1953-2006), and 116876 (AB 100) "NSF/ANSI/CAN 61: Q ≤ 1".

The bottle filler requires a mounting plate; either the Haws model 6700 in-wall or the 6700R on-wall support plate.



NOTES:

1. HOLD ROUGH-IN DIMENSIONS ± 1/4" (6.4mm)
2. WHEN INSTALLING THIS UNIT, LOCAL, STATE OR FEDERAL CODES SHOULD BE ADHERED TO. FOR INSTALLATION HEIGHTS OTHER THAN SHOWN, DIMENSIONS MARKED (*) MUST BE ADJUSTED ACCORDINGLY.
3. REFER TO 5874 SERIES OPERATION AND MAINTENANCE MANUAL FOR PUSH BUTTON AND VALVE INSTALLATION AND MAINTENANCE INSTRUCTIONS.
4. ROUGH IN DIMENSIONS FOR FOUNTAIN HEIGHTS:

CHILD WHEELCHAIR HEIGHT: SEE SHT 2 FIG 1
 WASTE: 26-1/4" (667mm)
 SUPPLY: 26-1/8" (664mm)
 MOUNTING HOLE: 24-13/16" (630mm)
 MOUNTING PLATE: 23-3/16" (589mm)
 FOUNTAIN: 24" (610mm)
 BUBBLER: 29-7/8" (756mm)

ADULT WHEELCHAIR HEIGHT: SEE SHT 2 FIG 2
 WASTE: 29-1/4" (743mm)
 SUPPLY: 29-1/8" (740mm)
 MOUNTING HOLE: 27-13/16" (706mm)
 MOUNTING PLATE: 26-3/16" (665mm)
 FOUNTAIN: 27" (686mm)
 BUBBLER: 32-7/8" (832mm)

STANDING ADULT HEIGHT: SEE SHT 2 FIG 3

WASTE: 34-3/4" (883mm)
 SUPPLY: 34-5/8" (879mm)
 MOUNTING HOLE: 33-5/16" (846mm)
 MOUNTING PLATE: 31-11/16" (805mm)
 FOUNTAIN: 32-1/5" (826mm)
 BUBBLER: 38-3/8" (972mm)

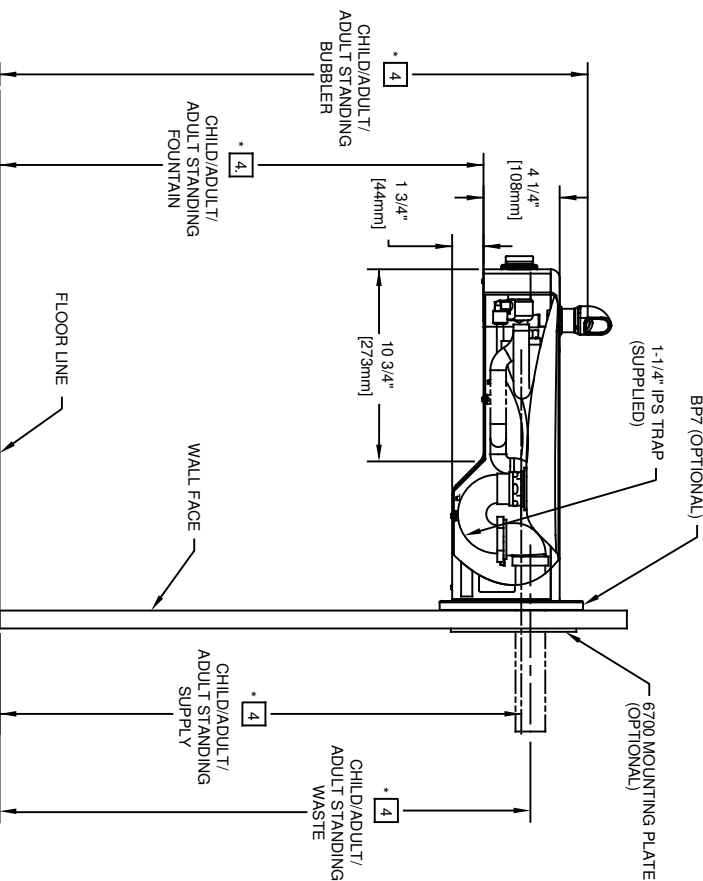
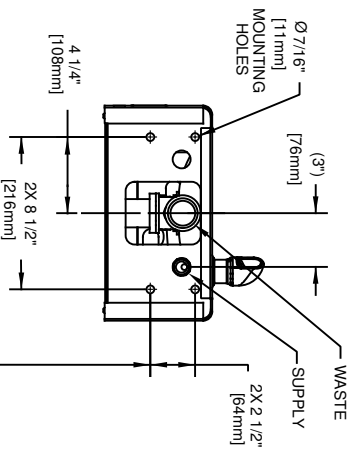
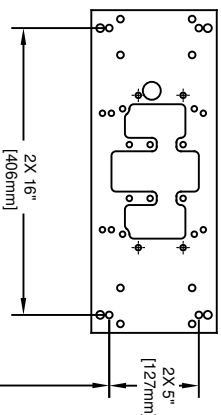
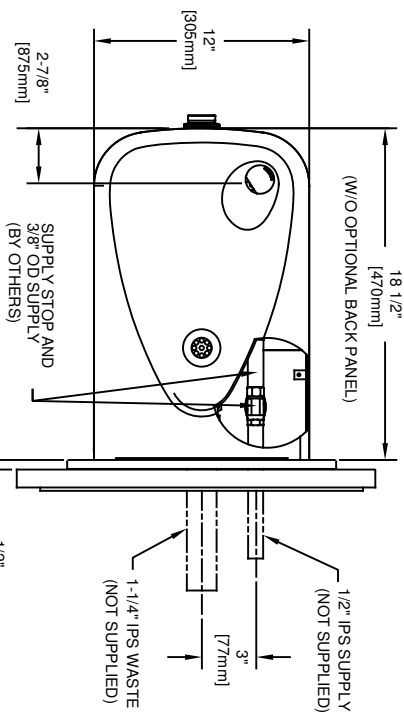
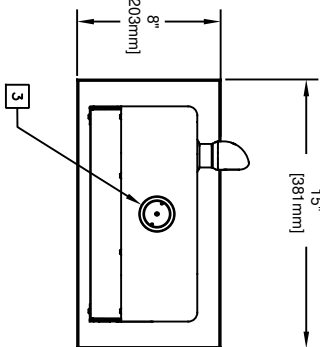

MOUNTING DETAIL

BACK VIEW

MOUNTING PLATE
(OPTIONAL, HAWS 6700)

HAWS

1459 KLEPPE LANE
 SPARKS, NEVADA, 89431
 (775) 359-4712 FAX (775) 359-7424
 E-MAIL: HAWS@HAWS.CO.COM
 WEBSITE: WWW.HAWS.CO.COM

ECN NO. REVISED PER BY: MODEL(S)
 ECN: 5215 JP
 DATE: 10/25/06 GC
 DRAWN: DATE: CHKD:
 C/FENNER: 10/25/06 GC
 APPROVED: DATE: SCALE: 1:1 DRAWING TYPE: INSTALLATION
 EV: 11/22/17 SHEET 1 OF 1

1107L

REVISION: 15

0002080232.D

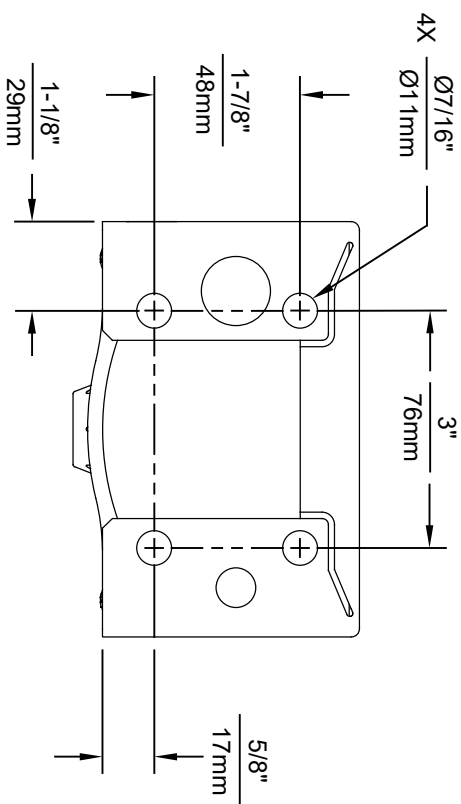
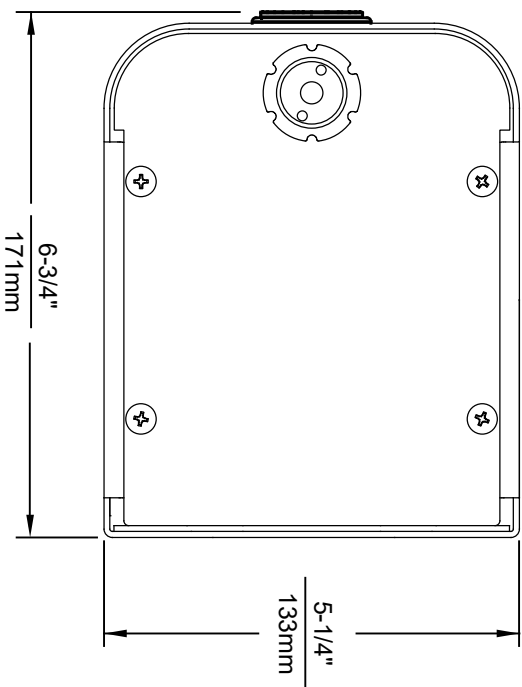
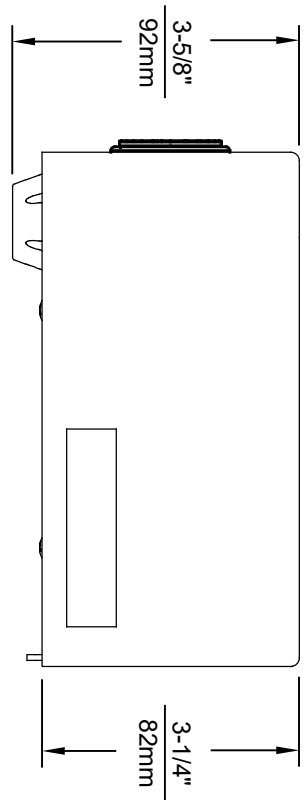

1920HO SERIES MOUNTING HOLE LOCATIONS
(3/8" - 16 UNC MOUNTING HARDWARE NOT SUPPLIED)

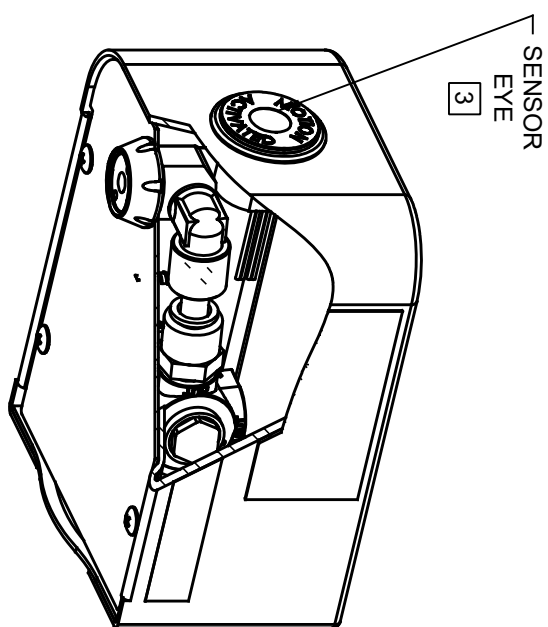

NOTES:

1. SEE SEPARATE INSTALLATION DRAWINGS FOR MOUNTING PLATES AND BACKPANELS
2. WHEN INSTALLING THIS UNIT, LOCAL, STATE OR FEDERAL CODES SHOULD BE ADHERED TO FOR INSTALLATION LOCATIONS, WASTE AND SUPPLY REQUIREMENTS OTHER THAN SHOWN.
3. REFER TO 1RKHO.H OPERATION & MAINTENANCE INSTRUCTIONS FOR SENSOR SETUP.



1455 KLEPPE LANE
SPARKS, NEVADA 89431
(775) 359-4712 FAX (775) 359-7424
E-MAIL: HAWS@HAWSCCO.COM
WEBSITE: WWW.HAWSCCO.COM

EQ. NO. REVISION	PER BY	DATE	SCALE	INSTALLATION	SIZE	SHEET
0510001063.D					A	1 OF 6
0510001063.D						4

THIS DOCUMENT IS TRUE AND CORRECT AT TIME OF PUBLICATION. CONTINUED PRODUCT IMPROVEMENTS MAKE SPECIFICATIONS AND MEASUREMENTS SUBJECT TO CHANGE WITHOUT NOTICE.

6700 MOUNTING PLATE
(BEHIND FINISH WALL)
- OR -
6700R RETROFIT PLATE
(ON TOP OF FINISH WALL)

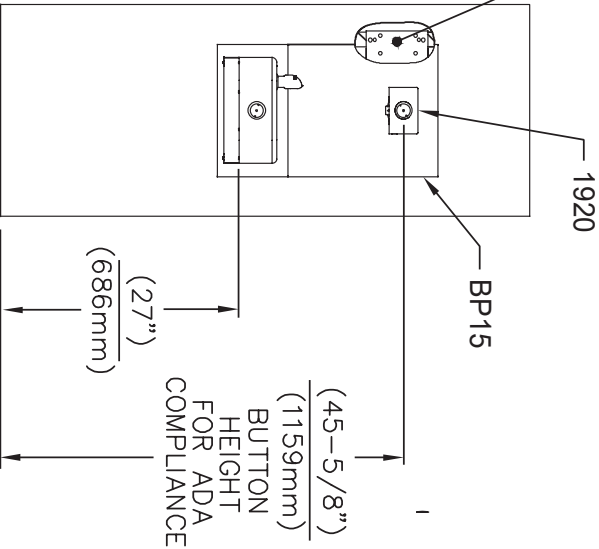

* IF YOUR FOUNTAIN IS THIS STYLE USE THESE DIMENSIONS

1. SEE SEPARATE INSTALLATION DRAWINGS FOR MOUNTING PLATES AND BACKPANELS
2. WHEN INSTALLING THIS UNIT, LOCAL, STATE OR FEDERAL CODES SHOULD BE ADHERED TO FOR INSTALLATION LOCATIONS, WASTE & SUPPLY REQUIREMENTS OTHER THAN SHOWN.

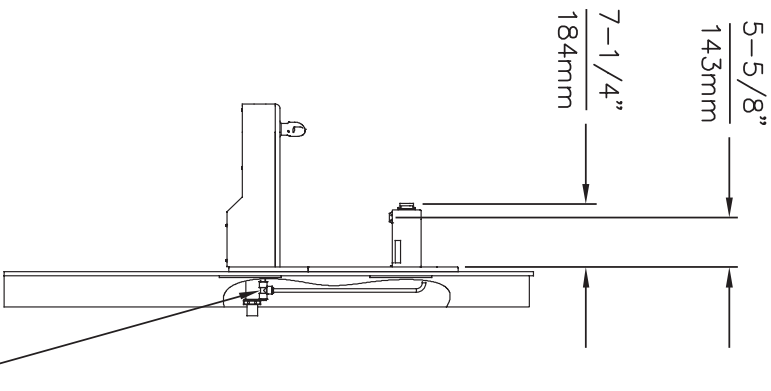
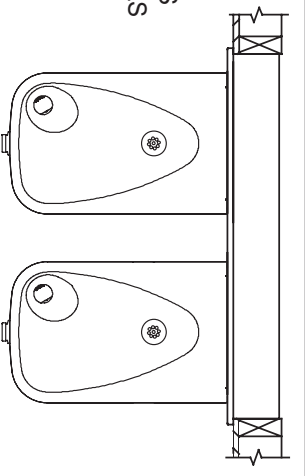

3/8" PUSH IN TEE
(CONNECT TO
FOUNTAIN SUPPLY)



1455 KLEPPPE LANE
SPARKS, NEVADA 89431
(775) 359-4712 FAX (775) 359-7424
E-MAIL: HAWS@HAWS.CO.COM
WEBSITE: WWW.HAWS.CO.COM

ECONO. REVISED PERBY:	MODEL(S)	MODEL 1107L
DRAWING:	EN. DATE:	CHGO
SCC:	DATE:	08/13/17
APPROVED:	SCALE:	NA
	DRAWING TYPE:	INSTALLATION
	SIZE:	A 1 SHEET 1 OF 2
	PART NUMBER:	1107L-20
	REVISION:	0A.1

©2017 Haws Corporation - All Rights Reserved. HAWS® and other trademarks used in these materials are the exclusive property of Haws Corporation.

DUAL FOUNTAIN

SHOWN FROM REAR

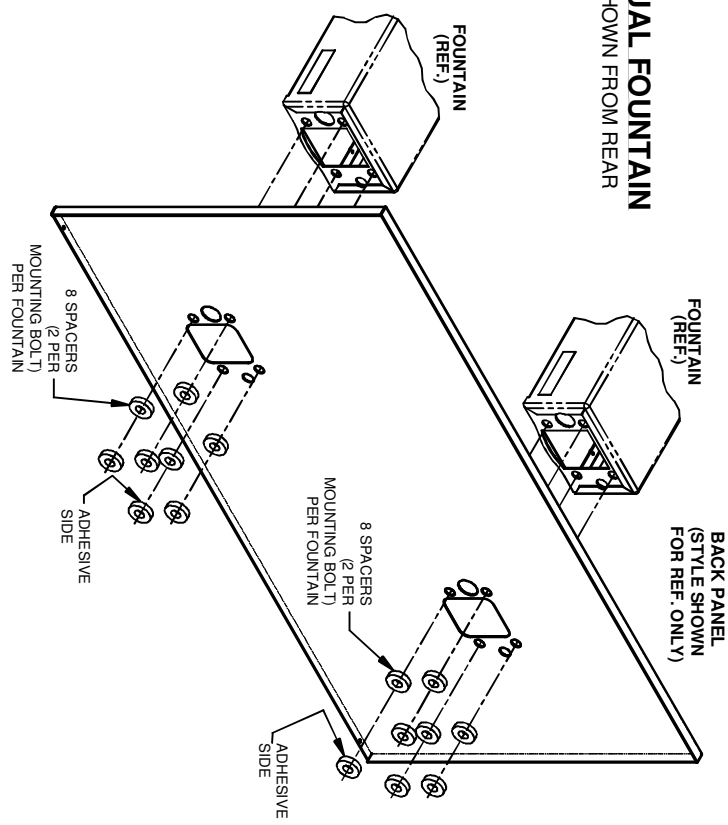

SINGLE FOUNTAIN

SHOWN FROM REAR

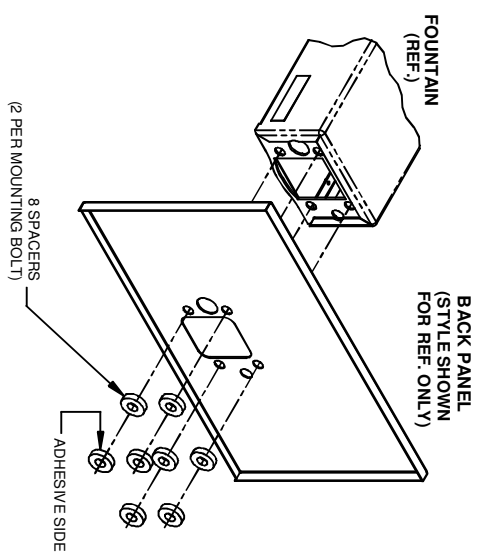

- NOTES:**
- 1 ON ALL BACK PANEL MODELS, SPACERS ARE NOT USED WHEN A MOUNTING FRAME IS USED EXCEPT AS SPECIFIED IN NOTE 2
 - 2 INDICATED SPACERS ARE USED WITH MOUNTING FRAME (DUAL ADJUSTABLE)

DUAL FOUNTAIN ADJUSTABLE

SHOWN FROM REAR

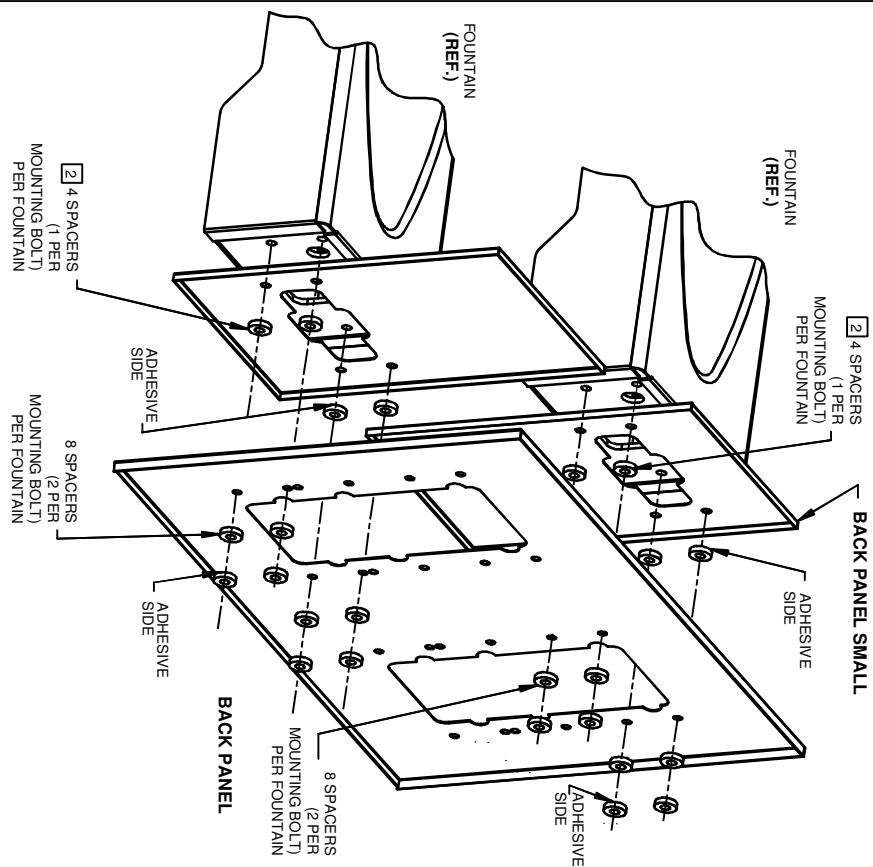

		MODELS(S)	
EGN NO. REVISED PERI BY:	EGN: 4595	BACK PANEL	
DRAWN: CHKD:	DATE: 10/28/92	SPACER INSTRUCTIONS	
APPROVED:	DATE:	INSTALLATION	
SCALE: 1:10		SIZE: A	SHEET 1 OF 1
1455 KLEPPE LANE		PART NUMBER	
SPARKS, NEVADA 89431		0002082219	
(775) 359-4712 FAX (755) 359-7424		DRAWING NO. REV	
E-MAIL: HAWS@HAWSCO.COM		08292001 5	
WEBSITE: WWW.HAWSCO.COM			

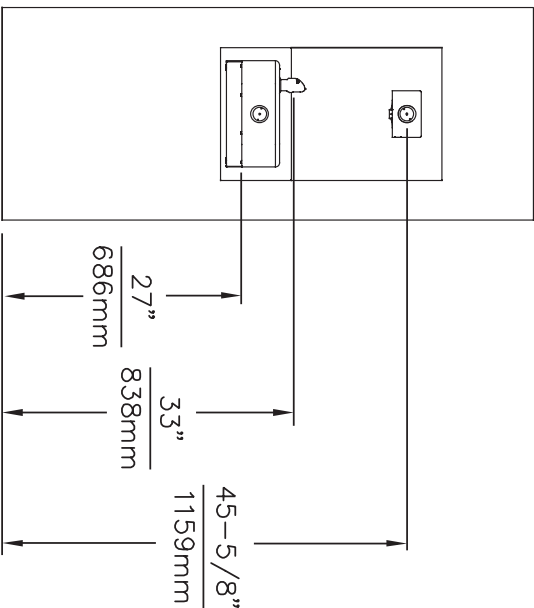

ADA ADULT ACCESSIBLE DIMENSIONS 1107L AND H1107.8
H1107.8 GRILL NOT SHOWN FOR CLARITY

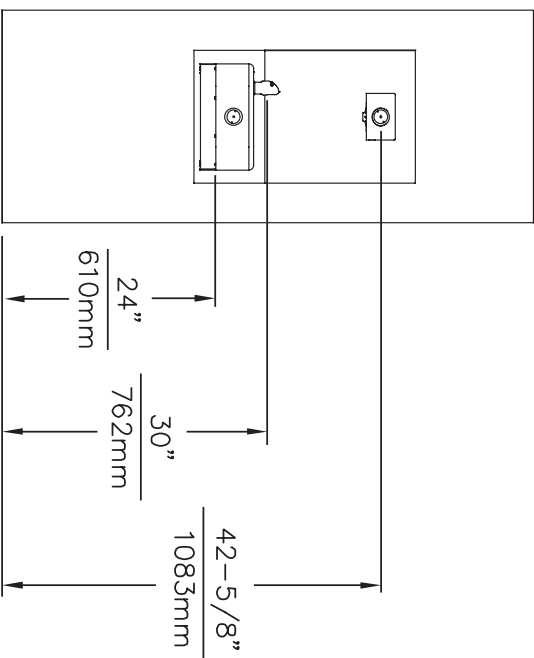

ADA CHILD ACCESSIBLE DIMENSIONS 1107L AND H1107.8
H1107.8 GRILL NOT SHOWN FOR CLARITY



Haws

1485 KLEPPE LANE
SPARKS, NEVADA 89431
(775) 359-4712 FAX (775) 359-7424
EMAIL: HAWS@HAWSCO.COM
WEBSITE: WWW.HAWSCO.COM

EQUIP. NO.	REVISED PER:	BY:	DATE:	CHKD.:	DATE:	MODEL(S)	SCALE:	SIZE:	SHEET:
DRAWN:	EQP. NO.	DATE:	CHKD.:	DATE:	MODEL(S)	SCALE:	SIZE:	SHEET:	
APPROVED:	DATE:	DATE:	DATE:	DATE:	MODEL(S)	SCALE:	SIZE:	SHEET:	
						MODEL 1107L AND H1107.8	N/A	A	1
						WITH MODEL 1920 BOTTLE FILLER			
						PART NUMBER			
						1107L-24			
						REVISION			
						0A.1			