

## FEATURES & BENEFITS

### CONSTRUCTION

Heavy-duty cast-iron ADA accessible bowl with a glossy white enamel finish is designed for the toughest of applications, and at the same time is gentle to all users with its soft rounded corners. Unit also ships with vandal-resistant bottom plates to provide added peace of mind.

### VANDAL RESISTANT

The bubbler heads, drain strainers and bottom plates are locked in place, discouraging unwanted vandal tampering.

### BUBBLER HEADS

Polished chrome-plated brass bubbler heads with integral laminar flow prevents splashing while providing a superior flow pattern. The integral 11/16" dia. basin shank and stainless anti-rotation roll pin for vandal resistance strength. Shielded, angled stream opening provides a steady source of drinking water at .45 gpm.

### FOUNTAIN VALVES

Fountain incorporates a touchless sensor operated stainless steel solenoid valves controlled by a transformer for hands free operation. A pressure regulator is used to adjust the bubbler flow according to incoming water pressures.

### MOUNTING

3/16" (.47 cm) thick steel mounting plate (sold separately) is larger, thicker and stronger than any other plate in the industry, and shall include the all-thread studs, nuts, and washers which allows for easy installation to a framed wall.

### INTEGRATED TRAP

All cast brass 1-1/4" NPT adjustable traps completely concealed inside bottom plates for easy installation and lack of unwanted access.

## OPTIONS

- Bottle Filler: Model 1920WHO, touchless bottle filler can be a stand-alone station, or mounted above Haws 1501HO series touchless drinking fountain models.
- Remote Drinking Fountain Water chiller: Model HCR8, 8 gph (30.3 L) remote water chiller provides instantaneous cooling to meet a continuous demand for chilled water.
- Support Frame: Model 6800 universal in-wall mounting support for use with most fountains.
- Bottle Filler Stand: Model BTL1311, add-on stainless steel stand to place bottle on when 1920 bottle filler is used.

For more information, visit [www.hawsc.com](http://www.hawsc.com) or call (888) 640-4297.



## SPECIFICATIONS

Model 1501HO2 vandal-resistant wall-mounted ADA motion activated drinking fountain shall include dual white enameled-iron basins, touchless sensor operated stainless steel solenoid valves with 30-second obstruction time-out controlled by a transformer, 100% lead-free waterways, polished chrome-plated brass vandal resistant bubbler heads, polished chrome-plated brass vandal resistant waste strainers, vandal-resistant bottom plates, white powder coated stainless steel back panel and 1-1/4" NPT traps.

**REQUIRES MODEL 6715 PRICED SEPARATELY**

**FOR INDOOR USE ONLY**

## APPLICATIONS

Perfect for either public or private settings, our gleaming white enameled iron series is one of the sturdiest wall mounted fountains Haws produces. This unit is the perfect fit for high traffic areas where there is a greater need for multiple drinking stations. Elegant gloss finish and color consistency throughout the enameled iron maintain the fountain's overall appeal so it always remains looking as new as it did when it was installed. Specifically, this type of wall mounted drinking fountain may be placed in settings such as: parks, schools, and other indoor/outdoor environments where the temperature remains above freezing. Model meets all current Federal Regulations for the disabled including those in the Americans with Disabilities Act. Haws manufactures drinking fountains, faucets and electric water coolers to be lead-free by all known definitions including NSF/ANSI/CAN 61- Section 9, NSF/ANSI/CAN 372, California Proposition 65, and the Federal Safe Drinking Water Act. Product is compliant to California Health and Safety Code 116875 (AB 1953-2006), and NSF/ANSI/CAN 61: Q ≤ 1.



**NOTES:**

- 1 1 1/4" DIM TO SLOTTED OPENING ON THE MOUNTING PLATE MUST BE ON THE TOP LEFT HAND SIDE WHEN INSTALLED.
- 2 1/2" DIM TO SLOTTED OPENING ON THE BACKPANEL MUST BE ON TOP LEFT HAND SIDE WHEN INSTALLED.
- 3 HOLD ROUGH-IN DIMENSIONS ± 1/4" (6.4MM).
4. WHEN INSTALLING THIS UNIT, LOCAL, STATE, OR FEDERAL CODES SHOULD BE ADHERED TO. FOR INSTALLATION HEIGHTS OTHER THAN SHOWN, DIMENSIONS MARKED (?) MUST BE ADJUSTED ACCORDINGLY.
- 5 REFER TO 5874 SERIES OPERATION AND MAINTENANCE MANUAL FOR PUSH BUTTON AND VALVE INSTALLATION/MAINTENANCE INSTRUCTIONS.

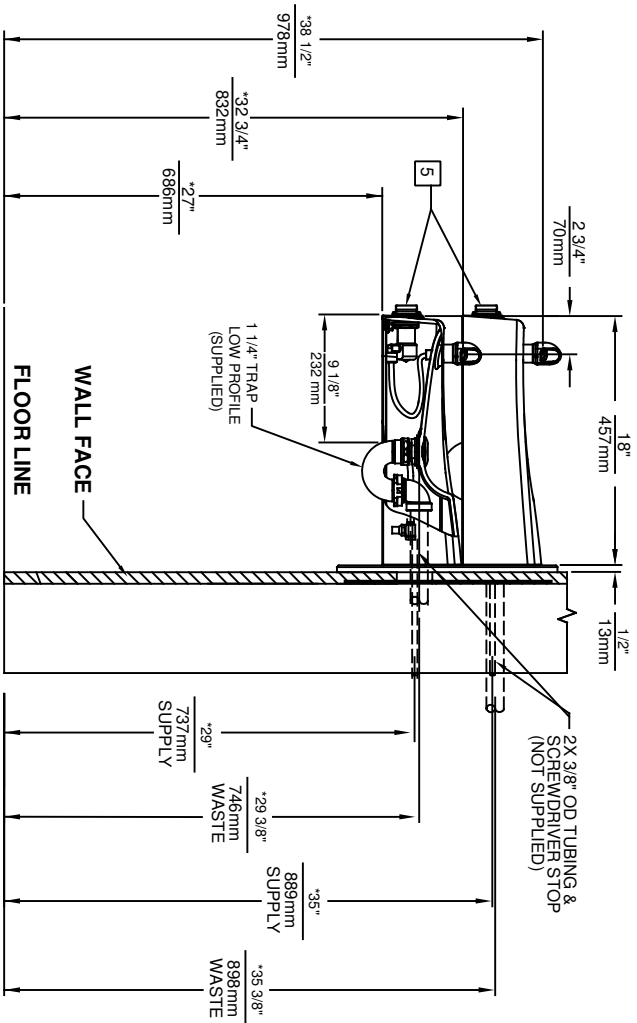
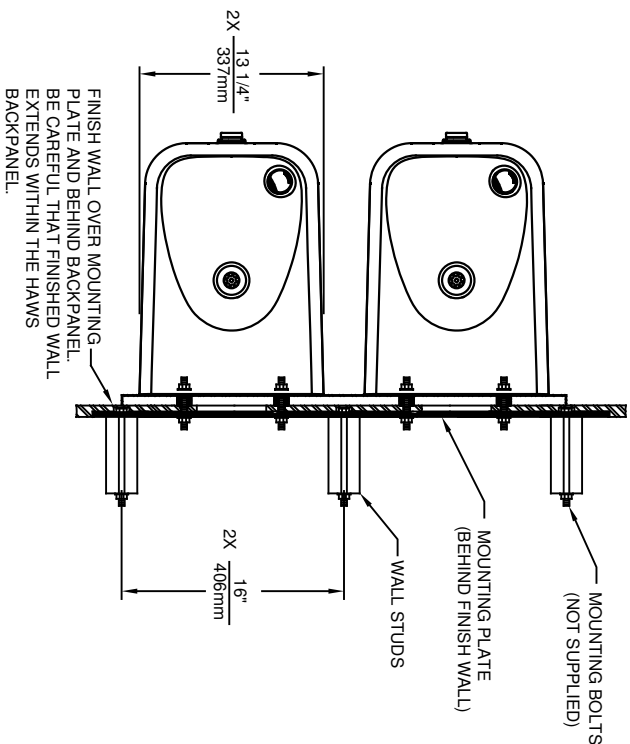
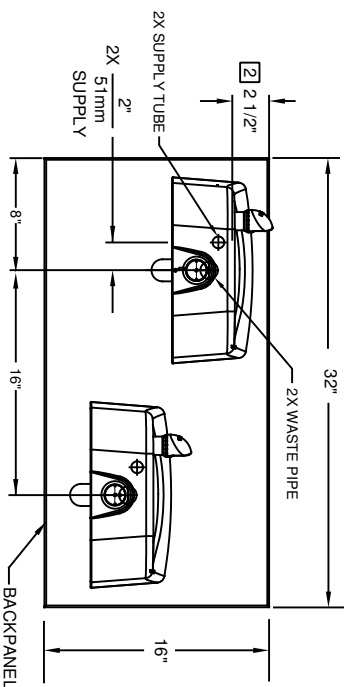
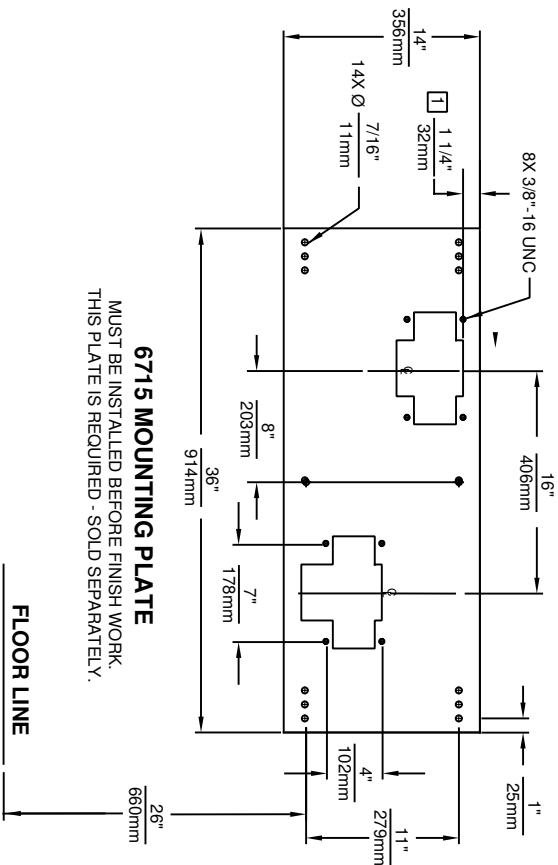

1459 KLEPPE LANE  
SPARKS, NEVADA 89431  
(775) 359-4712 FAX (775) 359-7424  
E-MAIL: HAWS@HAWS.CO.COM  
WEBSITE: WWW.HAWS.CO.COM

ECN NO. REVISED PER BY:	MODEL(S)	1501
DRAWN: HM	DATE: 08/25/15	DP
ECN: 5527	CHKD: EV	DATE: 04/02/20
APPROVED: EV	SCALE: 1:1	DRAWING TYPE: INSTALLATION
PART NUMBER: 0510000047.D	REVISION: 5	SHEET: 1 OF 1

NOTES:

- 2RKHO.P AND 2RKHO.H RETROFIT KITS ALLOW INDOOR FOUNTAINS TO BE CONVERTED FROM A HAWS 5874 PUSH BUTTON VALVE TO HANDS-OFF (TOUCHLESS) OPERATION. FOUNTAINS (NOT SUPPLIED) MAY BE MOUNTED ON THE EXTERNAL WALL OF A BUILDING PROVIDED THE TRANSFORMER SHALL BE MOUNTED INSIDE THE WALL AND PROTECTED FROM WATER AS SHOWN IN THIS INSTALLATION PER NEC/CEC AND LOCAL CODE. AVOID DIRECT CONTACT WITH SUNLIGHT ON THE SENSOR LENS.
- RETROFIT KIT MODEL:  
2RKHO.P: INDOOR HO RETRO-FIT KIT (INCLUDES 2X HO SENSOR WITH MOUNTING HARDWARE, 2X SOLENOID VALVE, 2X REGULATOR, WIRE SPLITTER, AND 100-240V PLUG-IN TRANSFORMER - SEE SHEET 2).  
2RKHO.H: INDOOR HO RETRO-FIT KIT (INCLUDES 2X HO SENSOR WITH MOUNTING HARDWARE, 2X SOLENOID VALVE, 2X REGULATOR, WIRE SPLITTER, AND 100-277V HARDWIRE TRANSFORMER - SEE SHEET 3).
- 2RKHO.P REQUIRES 100-240VAC POWER CONNECTION. 2RKHO.H REQUIRES 100-277V POWER CONNECTION.
- TRANSFORMERS MUST BE MOUNTED SUCH THAT THEY ARE PROTECTED FROM WATER.
- 2RKHO.P TRANSFORMER IS COMPATIBLE WITH TYPE A AND TYPE B NORTH AMERICAN ELECTRICAL OUTLETS. FOR OTHER RECEPTACLE TYPES, AN ADAPTER (NOT SUPPLIED) MUST BE PROVIDED BY OTHERS.

(NOTES CONTINUED ON SHEET 4)

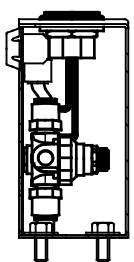

EXAMPLE 1920 BOTTLE FILLER INSTALLATION

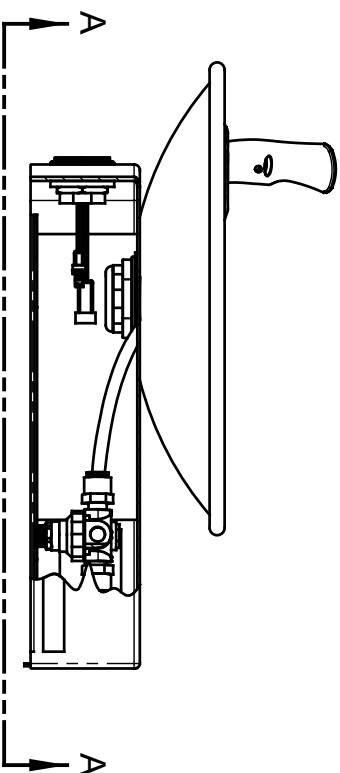

EXAMPLE 1011 FOUNTAIN INSTALLATION

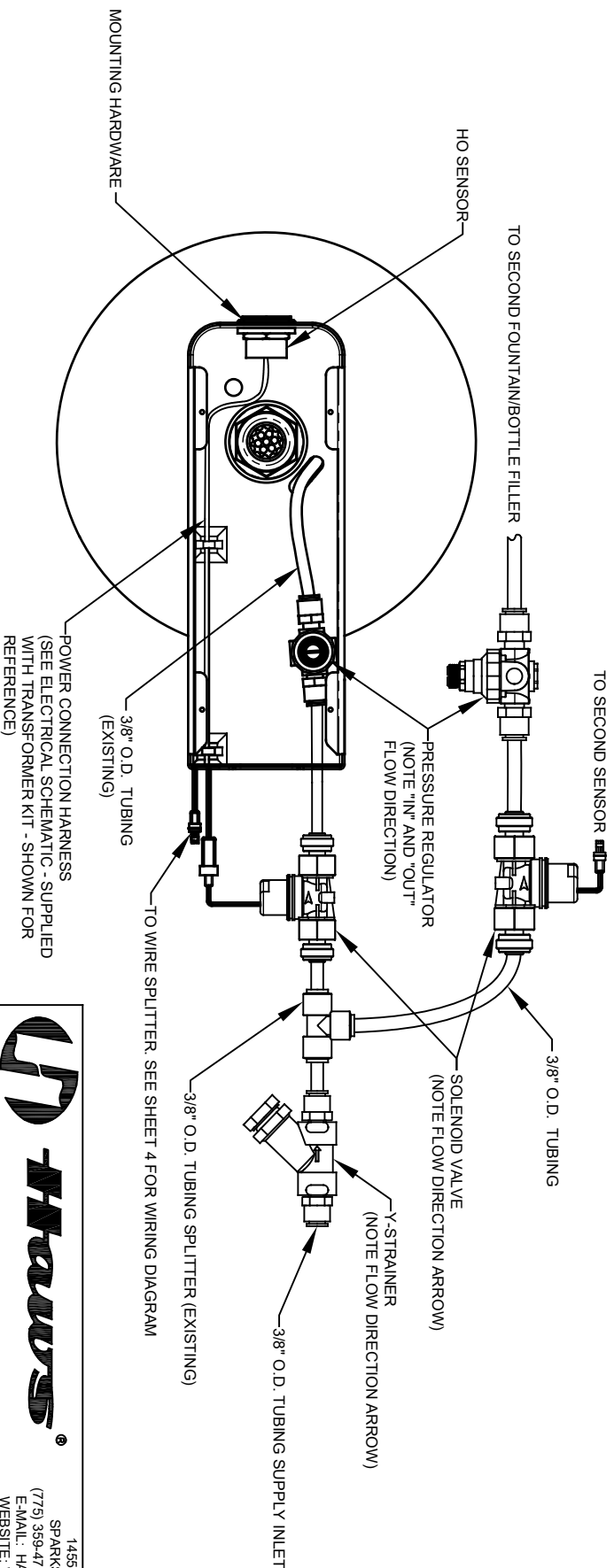

VIEW A - A

(BOTTOM PLATE OMITTED FOR CLARITY)

		<b>MODEL(S)</b>	
1456 KLEPPE LANE SPARKS, NEVADA, 89431 (775) 359-4712 FAX (775) 359-7424 E-MAIL: HAWS@HAWSCO.COM WEBSITE: WWW.HAWSCO.COM		2RKHO.P / 2RKHO.H DUAL HANDS-OFF RETRO-FIT KIT	
ECN NO. REVISED PER BY:	5849	ECN. 5749	BJM
DATE:	02/10/21	CHK'D:	FV
APPROVED:	BJM	DATE:	10/28/21
SCALE:	N/A	DRAWING TYPE:	INSTALLATION
PART NUMBER	0580001156.D	REVISION	4

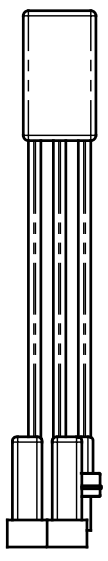

DUAL POWER SPLITTER

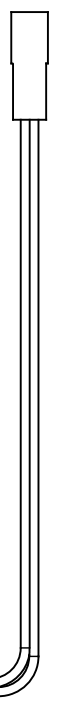

HARDWARE TRANSFORMER  
VRKH08

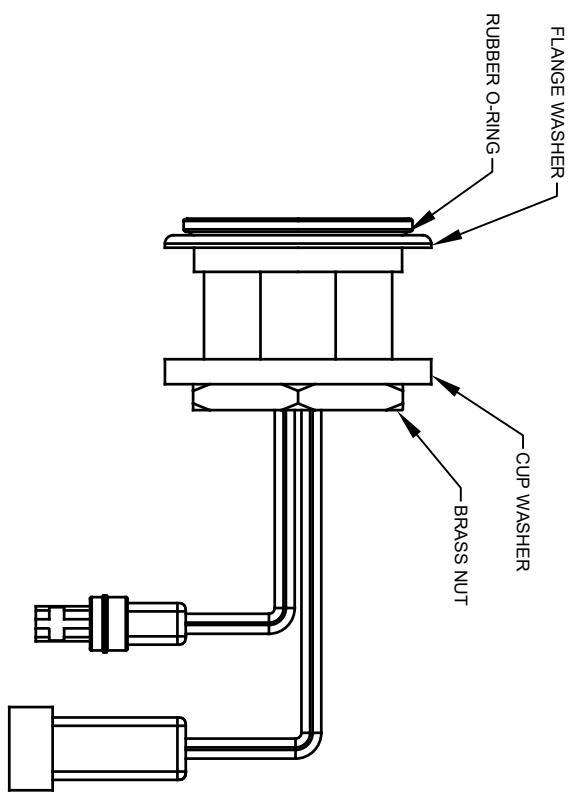

SOLENOID VALVE ASSEMBLY (2X)  
VRKH05

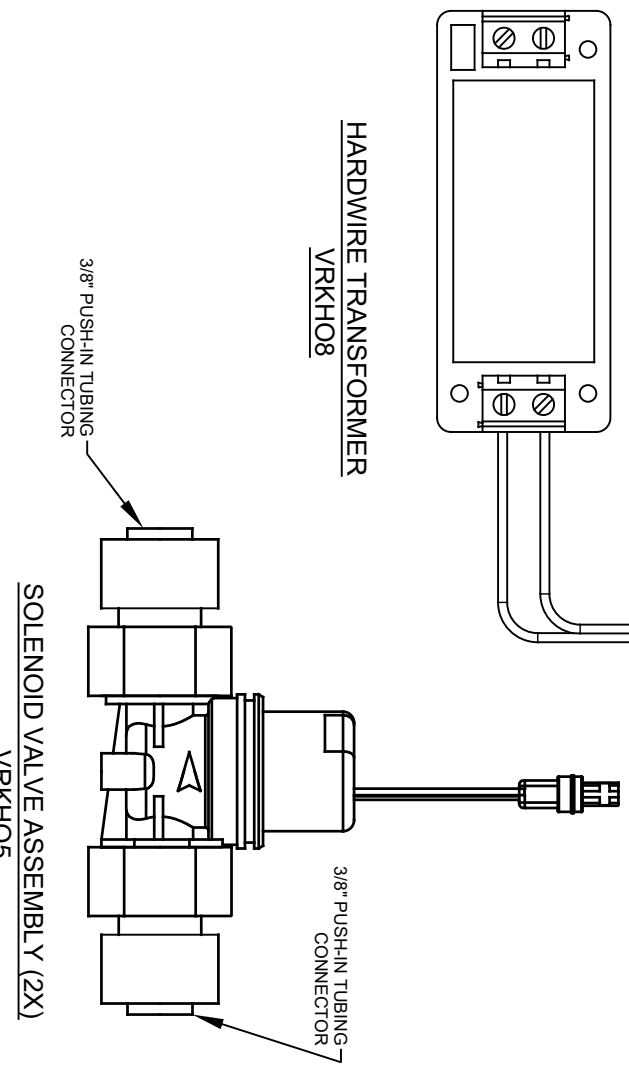

SOLENOID VALVE ASSEMBLY (2X)  
VRKH05

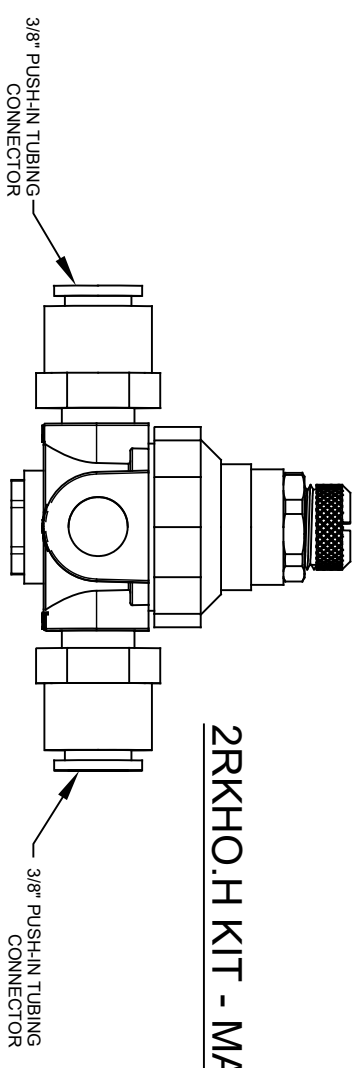

VALVE REGULATOR (2X)  
5867

2RKHO.H KIT - MAIN PARTS

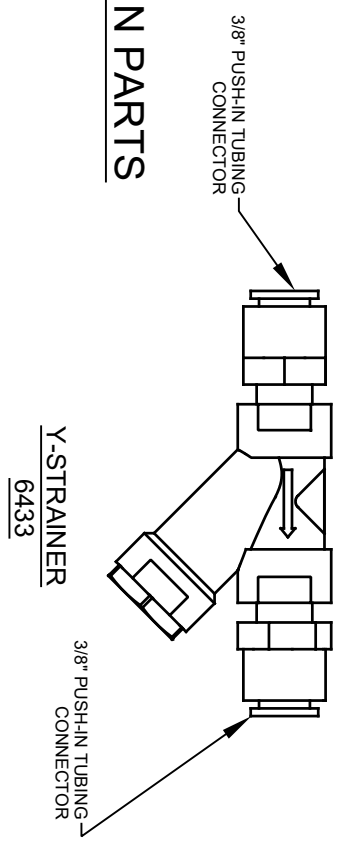

Y-STRAINER  
6433

		<b>Haws</b>	
1456 KLEPPE LANE SPARKS, NEVADA, 89431 (775) 359-4712 FAX (775) 359-7424 E-MAIL: HAWS@HAWS.CO.COM WEBSITE: WWW.HAWS.CO.COM			
ECN NO. REVISED PER BY: 5849 B.M.	DATE: 02/10/21	CHK'D: F.V.	DATE: 10/20/21
APPROVED: B.M.	SCALE: N/A	DRAWING TYPE: INSTALLATION	SIZE: A
MODEL(S) 2RKHO.P / 2RKHO.H		PART NUMBER 0580001156.D	
DUAL HANDS-OFF RETRO-FIT KIT		REVISION: 4	
DRAWING TYPE: N/A		SHEET 3 OF 4	