



model 1119HO-1920HO

ADA Vandal-Resistant Motion-Activated/Push Button Fountain w/Bottle Filler

## FEATURES & BENEFITS

### CONSTRUCTION

Rugged ADA accessible 18 gauge Type 304 stainless steel bowls and 14 gauge Type 304 Stainless Steel bottle filler. Unit features stainless steel satin finish back panels, vandal-resistant bottom plate, and 1-1/4" integrated trap.

### BOTTLE FILLER

Vandal-resistant, 14-gauge Type 304 stainless steel bottle filler housing with touchless operation and 1 gpm (3.78 L) laminar flow.

### FOUNTAIN VALVES

Fountain incorporates touchless sensor operated stainless steel solenoid valves controlled by a transformer on the bottle filler and on one side of the fountain, and a push-button activated valve which offers the only all stainless-steel valve body that is machined out of solid bar stock and is fully serviceable through the front of the push button assembly offering access to the water control cartridge and integral water supply strainer on the other.

### BUBBLER HEADS

Polished chrome-plated brass bubbler heads with integral 11/16" dia. basin shank and stainless anti-rotation roll pin for vandal resistance strength. Shielded, angled stream opening provides a steady, sanitary source of drinking water at .45 gpm.

### INTEGRATED TRAP

All-cast adjustable brass 1-1/4" NPT trap is internally mounted completely concealed within the fountain's bottom plate for easy installation and access.

### VANDAL-RESISTANT

The bubbler heads, push button, drain strainers and bottom plates are locked in place, discouraging unwanted vandal tampering.

## OPTIONS

Mounting Plate::Model 6700, in-wall mounting plate for model 1920.

Mounting Plate::Model 6700R, on-wall mounting plate for model 1920.

Mounting Plate: Model 6700.4, in-wall mounting plate which is 36" wide by 3/16" thick solid steel that spans three studs for a heavy-duty vandal-resistant rigid installation.

Support Frame: Model 6800 In-wall floor mounted fixture support legs, welded steel 4-bolt floor flanges, and supplied with 'U' bolts and hardware.

For more information, visit [www.hawsc.com](http://www.hawsc.com) or call (888) 640-4297.



## REQUIRED MODELS

### 1119HO / 6469 / 1920HO / BP32

Order these items to make up the model 1119HO-1920HO fountain and bottle filler with stainless steel back panel shown above.

**FOR INDOOR USE ONLY**

## SPECIFICATIONS

Model 1119HO-1920HO ADA vandal-resistant wall mounted motion-activated/push button drinking fountain and bottle filler shall include dual 18 gauge Type 304 Stainless Steel satin finish basins, 14 gauge bottle filler bracket, touchless sensor operated solenoid valves with 30-second obstruction time-out on the bottle filler and on one side of the fountain, and a vandal-resistant push-button operated stainless-steel valve with front-accessible cartridge and flow adjustment on the other, polished chrome-plated brass vandal-resistant bubbler heads, 1 gpm (3.78 L) laminar flow bottle filler, polished chrome-plated brass vandal-resistant waste strainers, vandal resistant bottom plates, stainless steel satin finish back panels, high and low fountain mounting levels, and 1-1/4" NPT traps. Manufactured to be lead-free by all known definitions including NSF/ ANSI/ CAN 61-Section 9, NSF/ANSI/ CAN 372, California Proposition 65, and the Federal Safe Drinking Water Act. Product is compliant to California Health and Safety Code 116875 (AB 1953-2006), and NSF/ ANSI/CAN 61: Q ≤ 1.



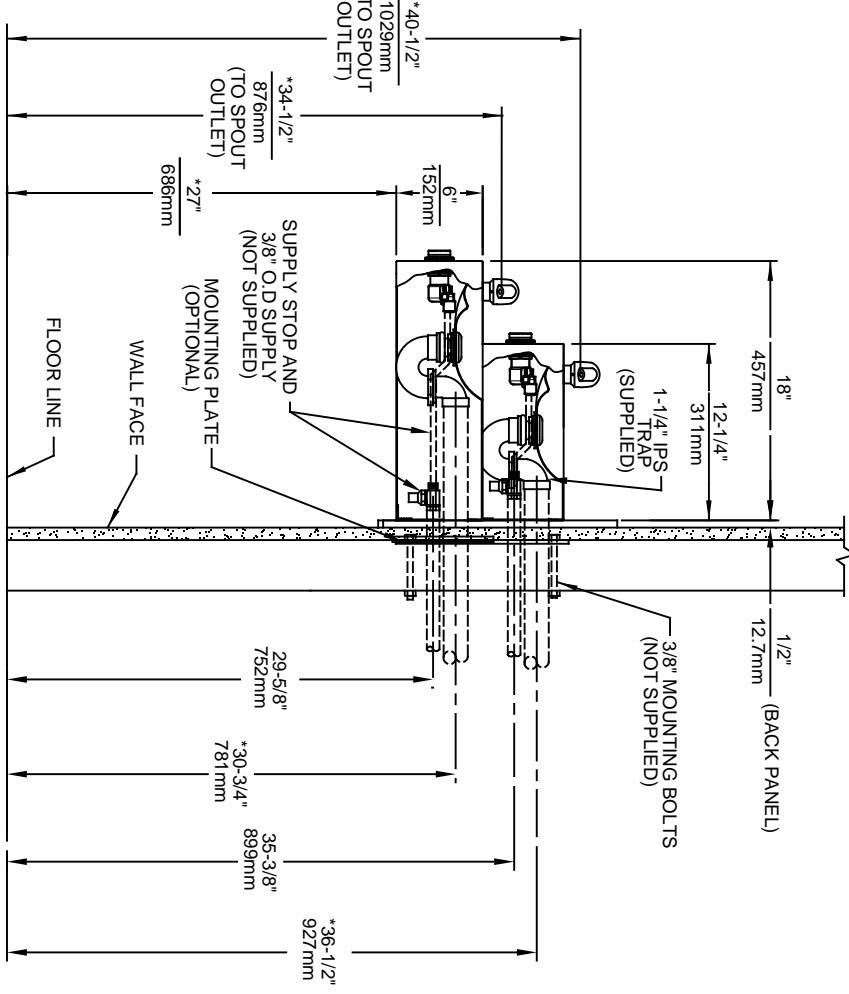
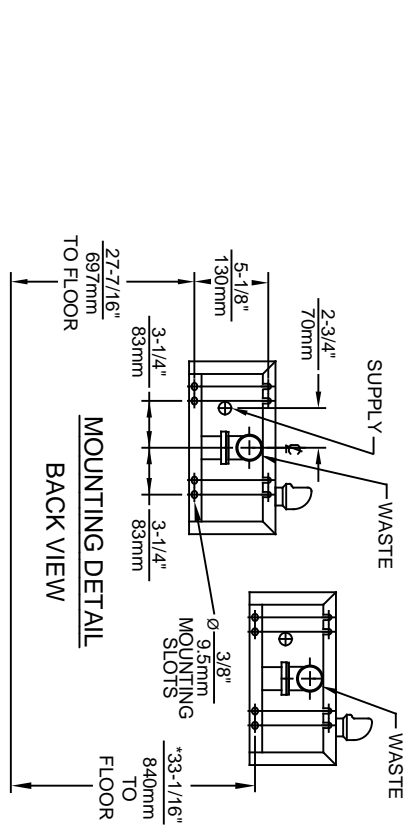
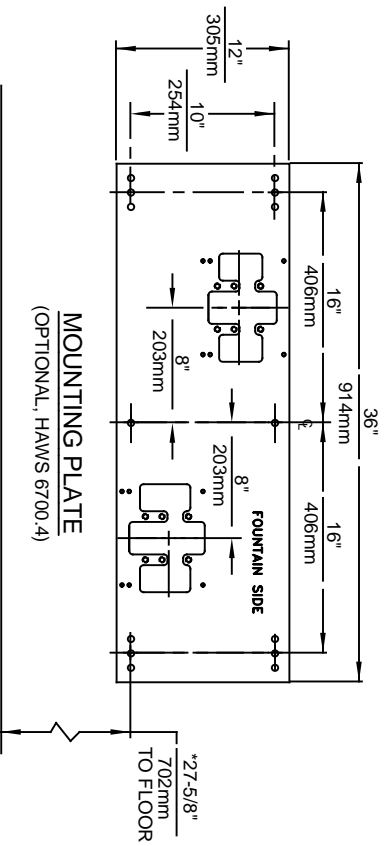
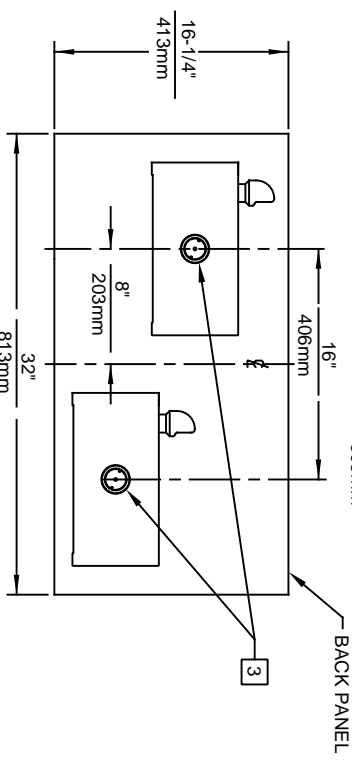
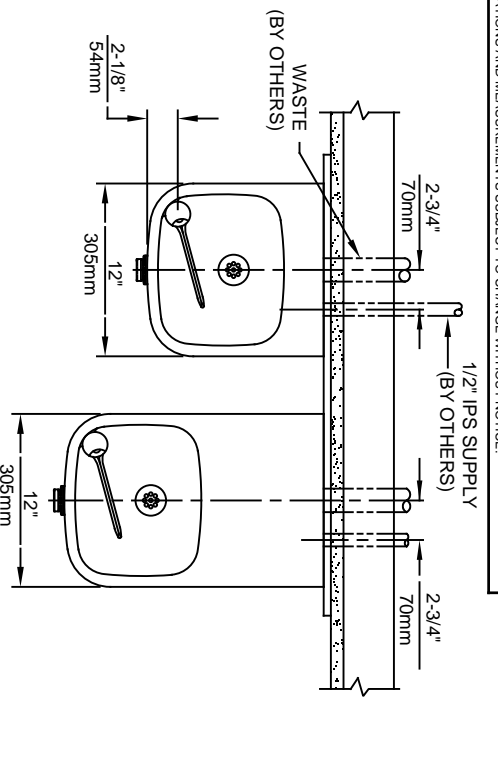

**NOTES:**

1. HOLD ROUGH-IN DIMENSIONS ± 1/4" (6.4mm).
2. WHEN INSTALLING THIS UNIT, LOCAL, STATE, OR FEDERAL CODES SHOULD BE ADHERED TO, FOR INSTALLATION HEIGHTS OTHER THAN SHOWN, DIMENSIONS MARKED (\*) MUST BE ADJUSTED ACCORDINGLY.
3. REFER TO 5874 SERIES/VK5874 OPERATION AND MAINTENANCE MANUAL FOR PUSH BUTTON AND VALVE INSTALLATION/MAINTENANCE INSTRUCTIONS.

		<b>MODEL(S)</b>	
1456 KLEPPE LANE SPARKS, NEVADA, 89431 (775) 359-4712 FAX (775) 359-7424 E-MAIL: HAWWS@HAWSCO.COM WEBSITE: WWW.HAWSCO.COM		1119	
ECN NO. REVISED PER BY:	ECN: 5330	DATE:	CHKD:
DATE:	04/15/98	DP:	
APPROVED:	DATE:	SCALE:	DRAWING TYPE:
NE:	02/28/20	1:14	INSTALLATION
PART NUMBER		SHEET 1 OF 1	
0002076716.D		REVISION: 20	

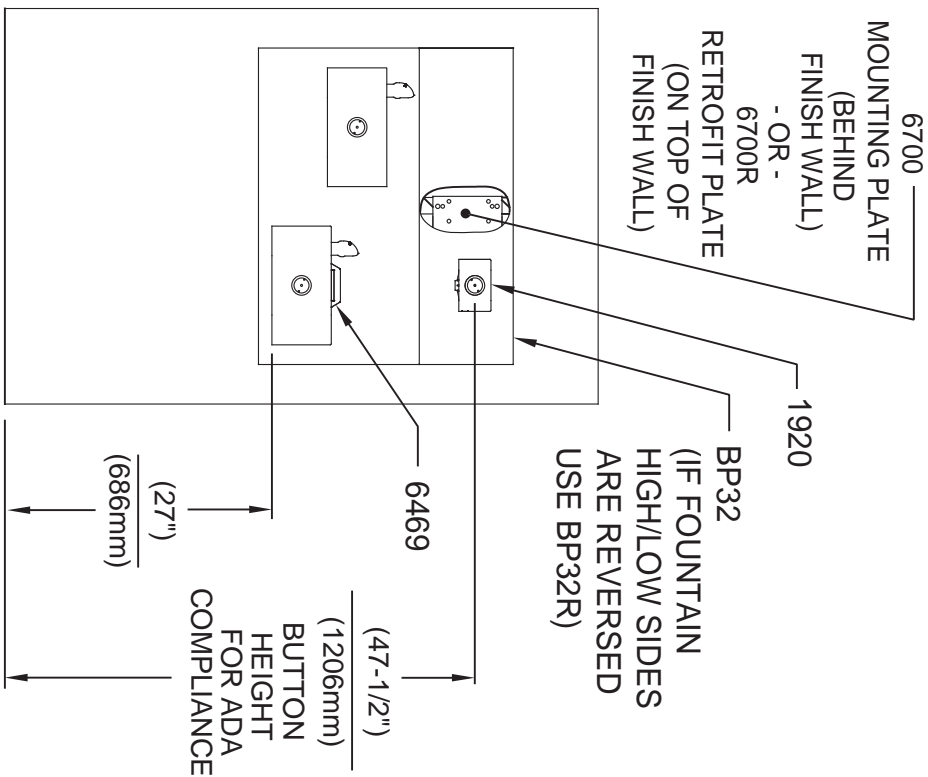

**INSTALLATION ABOVE HAWES 1119, 1119.14, H1119.8**

\* IF YOUR FOUNTAIN IS THIS STYLE USE THESE DIMENSIONS

1. SEE SEPARATE INSTALLATION DRAWINGS FOR MOUNTING PLATES, BACKPANELS & DRIP TRAY

2. WHEN INSTALLING THIS UNIT, LOCAL, STATE OR FEDERAL CODES SHOULD BE ADHERED TO FOR INSTALLATION LOCATIONS, WASTE & SUPPLY REQUIREMENTS OTHER THAN SHOWN.

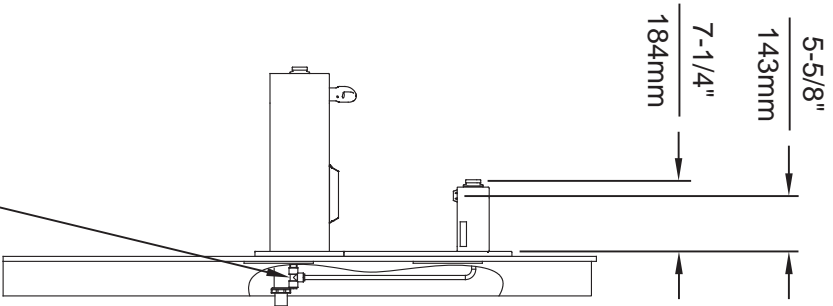
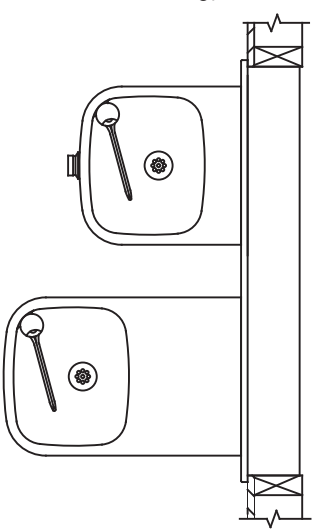

		<b>Haws</b>	
EQ# NO. REVISED PER BY:	MODEL(S)	1920/1920HPS	
DATE:	SCALE:	N/A	
DATE:	DRAWING TYPE:	INSTALLATION	
DATE:	SIZE:	A	
DATE:	SHEET:	3 OF 6	
DATE:	REVISION:	6	
1455 KLEPPE LANE SPARKS, NEVADA 89431 (775) 359-4712 FAX (775) 359-7424 E-MAIL: HAWS@HAWS.CO.COM WEBSITE: WWW.HAWS.CO.COM			
PART NUMBER		0510000490.D	

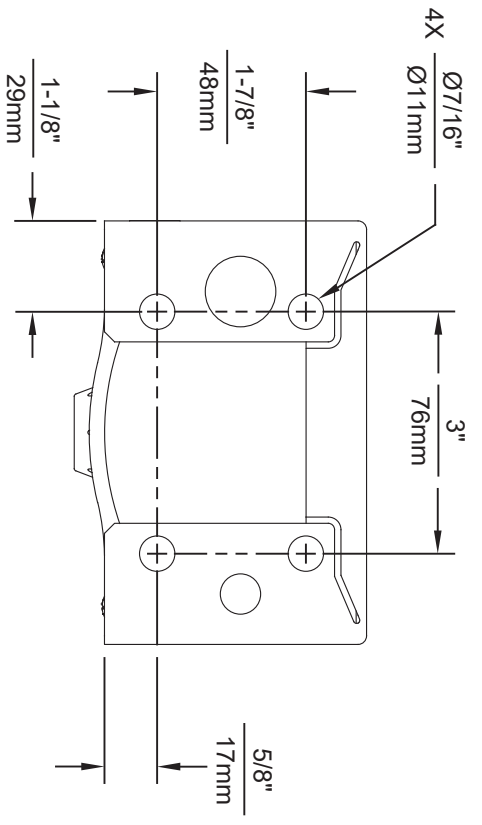
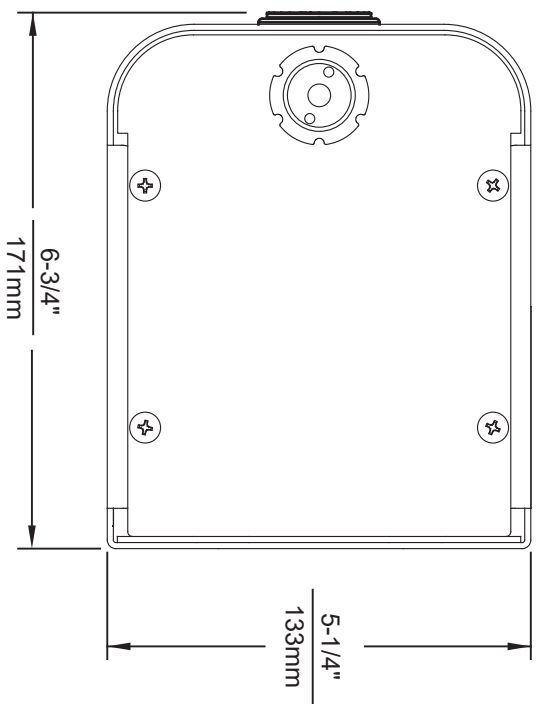
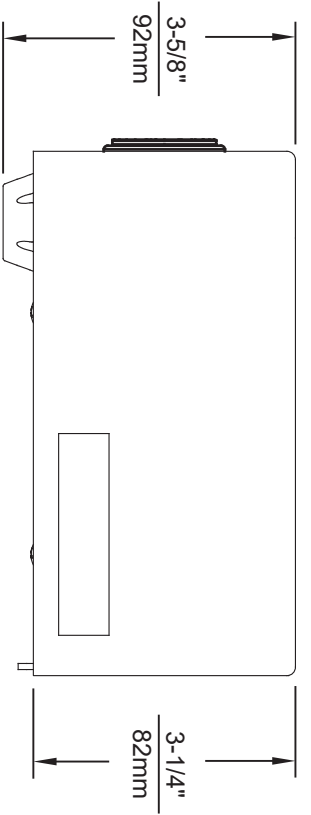

1920HO SERIES MOUNTING HOLE LOCATIONS  
(3/8\"-16 UNC MOUNTING HARDWARE NOT SUPPLIED)

NOTES:

1. SEE SEPARATE INSTALLATION DRAWINGS FOR MOUNTING PLATES AND BACKPANELS
2. WHEN INSTALLING THIS UNIT, LOCAL, STATE OR FEDERAL CODES SHOULD BE ADHERED TO FOR INSTALLATION LOCATIONS, WASTE AND SUPPLY REQUIREMENTS OTHER THAN SHOWN.
3. REFER TO 1RKHO.H OPERATION & MAINTENANCE INSTRUCTIONS FOR SENSOR SETUP.

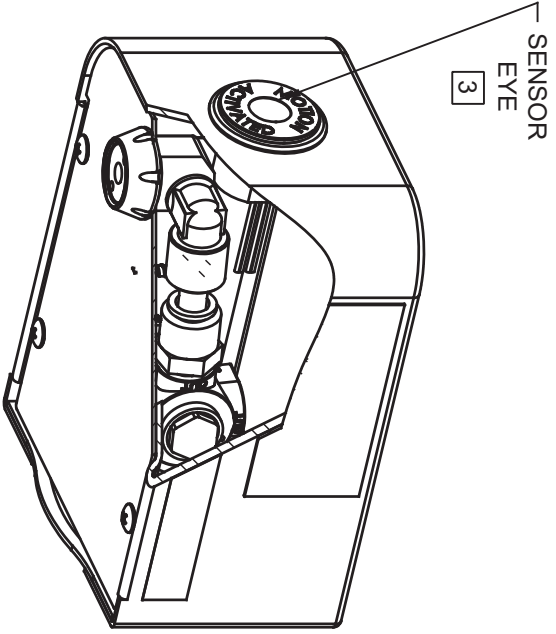

		<b>Haws</b>	
1459 KLEPPE LANE SPARKS, NEVADA, 89431 (775) 359-4712 FAX (775) 359-7424 E-MAIL: HAWS@HAWSCO.COM WEBSITE: WWW.HAWSCO.COM		MODEL(S) 1920HO/1920HPSHO/1920WHO	
ECN NO. REVISED PER BY: 5574 ECN: 5694 BJM	DATE: CHKD: 08/18/20 FV	APPROVED: BJM	DATE: 09/13/21
SCALE: N/A	DRAWING TYPE: INSTALLATION	SIZE: A	SHEET 1 OF 6
PART NUMBER 0510001063.D		REVISION 4	

### 6469 BOTTLE FILLER DRIP TRAY INSTALLATION

1. THE 6469 BOTTLE FILLER DRIP TRAY ALLOWS THE INSTALLATION OF THE 1920 BOTTLE FILLER OVER HAWS 1109/1119 MODEL DRINKING FOUNTAINS. CENTER THE LOWER DRAIN PAN ALONG THE CENTERLINE OF THE FOUNTAIN.
2. EXTEND THE FRONT EDGE OF THE LOWER DRAIN PAN OVER THE EDGE OF THE FOUNTAIN BOWL BY APPROXIMATELY 1/4" (6mm). IT IS RECOMMENDED TO TEMPORARILY TAPE THE DRAIN PAN IN PLACE, INSTALL THE TOP COVER, AND ACTIVATE THE BOTTLE FILLER TO VERIFY THE WATER STREAM IS ALIGNED TO THE INLET HOLE. VERIFY THE LIP OF THE TOP COVER HANGS OVER THE EDGE OF THE FOUNTAIN BOWL.
3. MARK THE DRAIN PAN HOLE LOCATIONS ON THE FOUNTAIN. THE DRAIN PAN CAN NOW BE PERMANENTLY INSTALLED USING AN APPROPRIATE FASTENING METHOD (FASTENERS NOT SUPPLIED). FASTENING OPTIONS INCLUDE THRU BOLTS, RIVETS, TACK WELDS, AND DOUBLE-SIDED FOAM TAPE. INSTALL THE TOP COVER AND SECURE TO THE DRAIN PAN WITH THE SUPPLIED 4-40 FLATHEAD SCREWS.

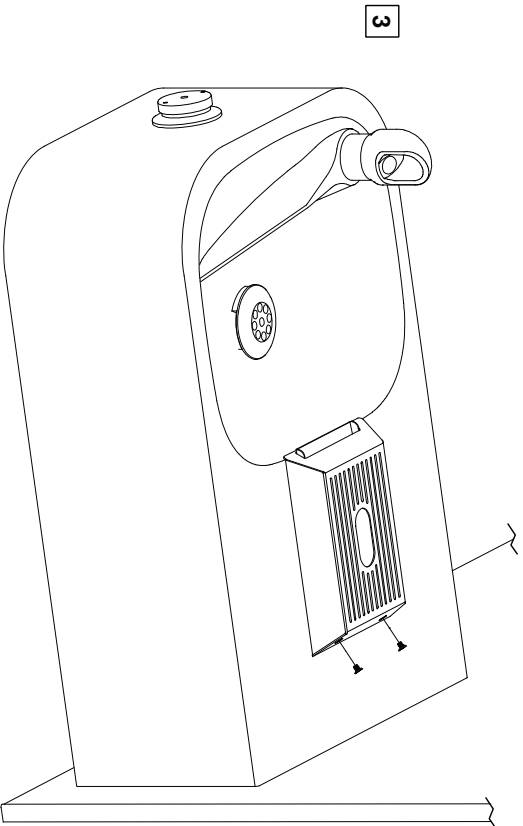
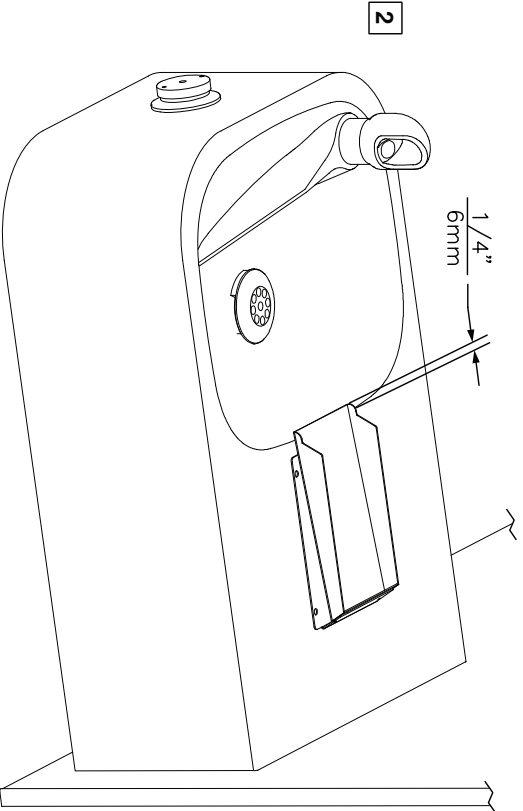
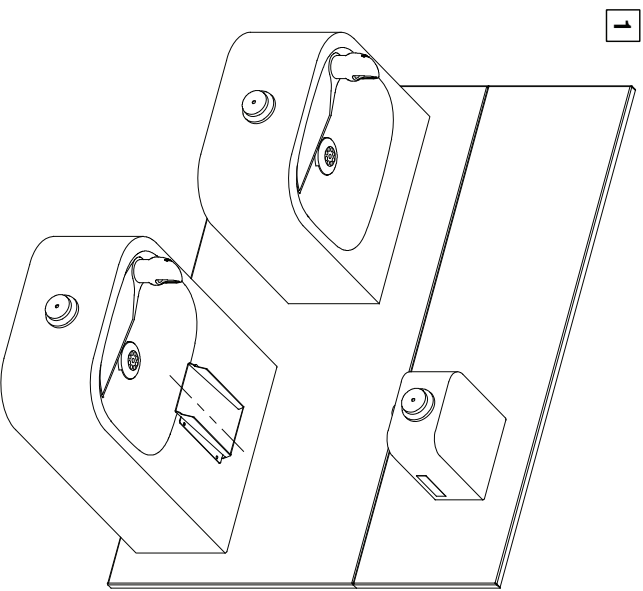

		<b>Haws</b>	
1455 KLEPPE LANE SPARKS, NEVADA 89431 (775) 358-4712 FAX (775) 359-7424 E-MAIL: HAWS@HAWSCO.COM WEBSITE: WWW.HAWSCO.COM			
CON. NO. 5150	REVISED PER BY: MJ	MODEL(S)	
DRAWN: MJ	DATE: 01/10/17	DRAWING: 6469 BOTTLE FILLER DRIP TRAY	
APPROVED: TV	DATE: 01/10/17	SCALE: 1:4	DRAWING TYPE: INSTALLATION
PART NUMBER: 0510000657.D		REVISION: 1	
SIZE: A		SHEET: 1 OF 1	

THIS DOCUMENT IS TRUE AND CORRECT AT TIME OF PUBLICATION. CONTINUED PRODUCT IMPROVEMENTS MAKE SPECIFICATIONS AND MEASUREMENTS SUBJECT TO CHANGE WITHOUT NOTICE.

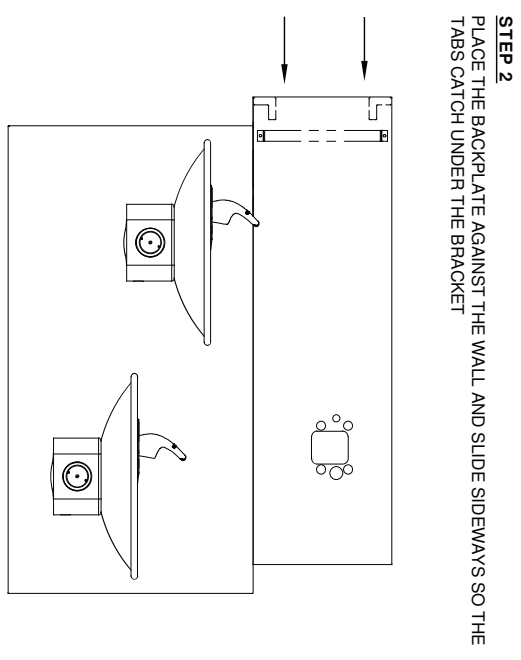
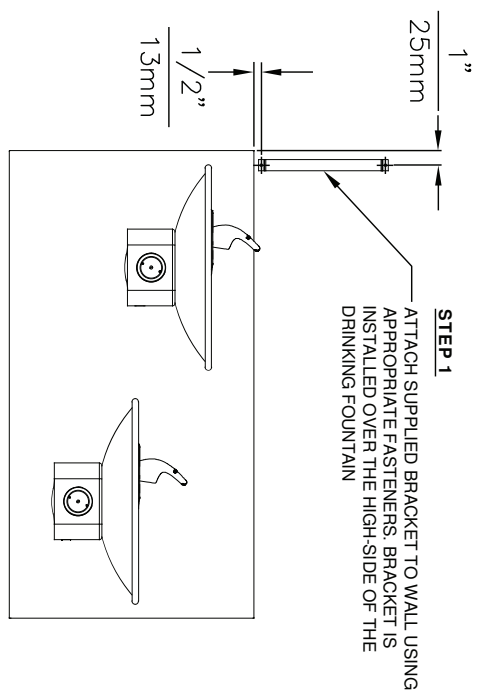

**STEP 3**  
INSTALL THE BOTTLE FILLER PER THE INSTRUCTIONS SUPPLIED WITH THE UNIT

NOTES:  
1. WHEN INSTALLING THIS UNIT, LOCAL, STATE OR FEDERAL CODES SHOULD BE ADHERED TO.

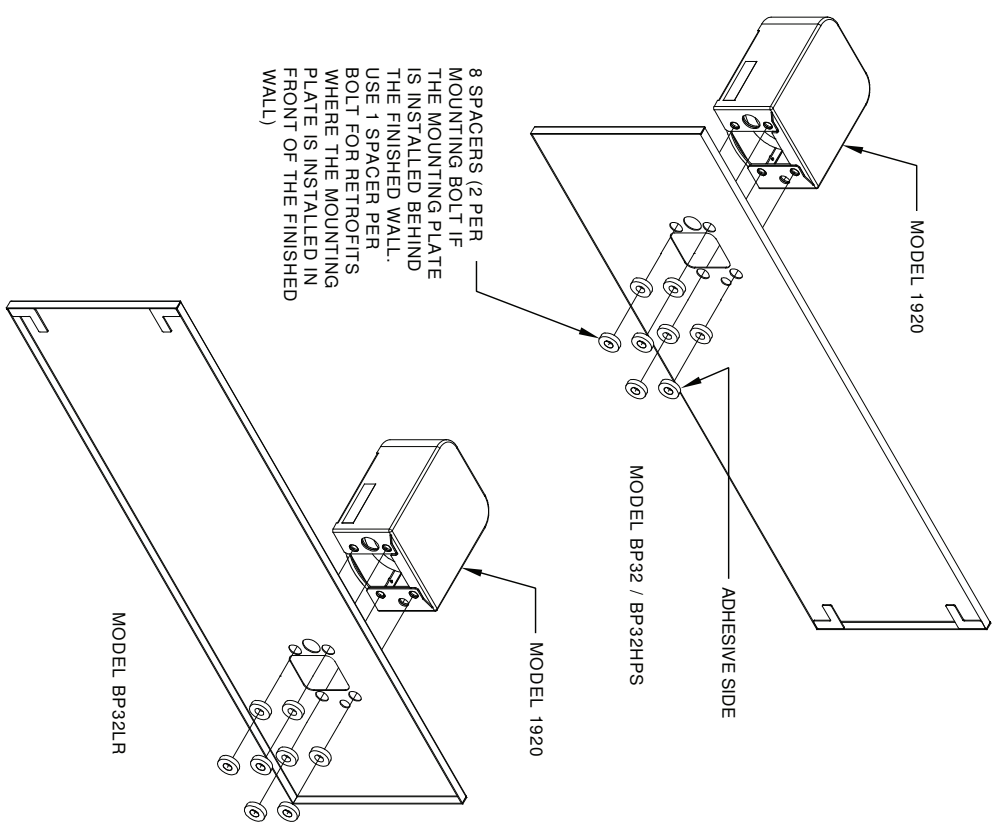

**INSTALLATION OVER DOUBLE FOUNTAIN**  
SHOWN FROM REAR



**Haws**

1455 KLEPPER LANE  
SPARKS, NEVADA 89431  
(775) 359-4712 FAX (775) 359-7424  
E-MAIL: HAWS@HAWS.CO.COM  
WEBSITE: WWW.HAWS.CO.COM

ENGINEERED BY: M.J.	MODEL(S)	PART NUMBER
DRAWN BY: E.C./C.R.	DRAWING, BACK PANEL SPACER INST, BF	0310000493.D
DATE: 02/27/17	SCALE: 1:1	REVISION
APPROVED BY: F.V.	DRAWING TYPE: INSTALLATION	2
DATE: 02/27/17	SIZE: A	SHEET 2 OF 2

©2017 Haws Corporation - All Rights Reserved. HAWS® and other trademarks used in these materials are the exclusive property of Haws Corporation.