



**Haws**<sup>®</sup>

model 1107LHO-1920HO

ADA Vandal-Resistant Motion-Activated Fountain and Bottle Filler

## FEATURES & BENEFITS

### CONSTRUCTION

One-piece stamped basin with low-profile design made of 14-gauge Type 304 stainless steel with integral 1/4" (.6 cm) mounting plate, and vandal-resistant bottom plate. Satin finish resists stains and corrosion.

### BOTTLE FILLER

14-gauge Type 304 stainless steel bottle filler housing with touchless operation and 1 gpm (3.78 L) laminar flow with 30-second obstruction time-out.

### FOUNTAIN VALVES

Fountain incorporates touchless sensor operated stainless steel solenoid valves controlled by a transformer for hands-free operation. A pressure regulator is used to adjust the bubbler flow according to incoming water pressures

### BUBBLER HEAD

Polished chrome-plated brass bubbler head with integral 11/16" dia. basin shank and stainless anti-rotation roll pin for vandal resistance strength. Shielded, angled stream opening provides a steady, sanitary source of drinking water at .45 gpm.

### TAMPER RESISTANT

30-second obstruction time-out to reduce tampering of sensor.

### VANDAL-RESISTANT

The bubbler head, sensor, drain strainer and bottom plate are locked in place, discouraging unwanted vandal tampering.



## OPTIONS

Mounting Plate: Model 6700, in-wall mounting plate for model 1920HO and/or model 1107L.

Mounting Plate: Model 6700R, on-wall mounting plate for model 1920HO.

Support Frame: Model 6800 In-wall floor mounted fixture support legs, welded steel 4-bolt floor flanges, and supplied with 'U' bolts and hardware.

Bottle Filler Stand: Model BTL1107, add-on stainless steel stand to place bottle on when 1920 bottle filler is used.

Custom Logo Panel: Standard Model 6475 comes with "Hydration By Haws™" logo. Customize the panel with your choice of logo, slogan, or graphic. For customization, call 888-640-4297.

## REQUIRED MODELS

### 1107LHO / BP7 / 1920HO / BP15

Order these items to make up the Model 1107LHO-1920HO fountain with stainless steel back panel, bottle filler with stainless steel back plate.

**FOR INDOOR USE ONLY**

## SPECIFICATIONS

Model 1107LHO-1920HO wall-mounted vandal-resistant ADA motion activated drinking fountain and bottle filler shall include a 14-gauge Type 304 Stainless Steel satin-finish basin with integral 1/4" stainless steel mounting plate, 14 gauge bottle filler bracket, touchless sensor operated solenoid valves with 30-second obstruction time-out controlled by a transformer, 100% lead-free waterways, polished chrome plated brass vandal-resistant bubbler head, 1 gpm (3.78 L) laminar flow bottle filler, polished chrome-plated brass vandal-resistant waste strainer, vandal-resistant bottom plates, and 1-1/4" NPT integral trap. Unit can be mounted to meet ADA or Child ADA specifications. Manufactured to be lead-free by all known definitions including NSF/ANSI/CAN 61-Section 9, NSF/ANSI/CAN 372, California Proposition 65, and the Federal Safe Drinking Water Act. Product is compliant to California Health and Safety Code 116875 (AB 1953-2006), and NSF/ANSI/CAN 61: Q ≤ 1.



**NOTES:**

1. HOLD ROUGH-IN DIMENSIONS ± 1/4" (6.4mm)
2. WHEN INSTALLING THIS UNIT, LOCAL, STATE OR FEDERAL CODES SHOULD BE ADHERED TO. FOR INSTALLATION HEIGHTS OTHER THAN SHOWN, DIMENSIONS MARKED (\*) MUST BE ADJUSTED ACCORDINGLY.
3. REFER TO 5874 SERIES OPERATION AND MAINTENANCE MANUAL FOR PUSH BUTTON AND VALVE INSTALLATION AND MAINTENANCE INSTRUCTIONS.
4. ROUGH IN DIMENSIONS FOR FOUNTAIN HEIGHTS:

- CHILD WHEELCHAIR HEIGHT: SEE SHT 2 FIG 1  
 WASTE: 26-1/4" (667mm)  
 SUPPLY: 26-1/8" (664mm)  
 MOUNTING HOLE: 24-13/16" (630mm)  
 MOUNTING PLATE: 23-3/16" (589mm)  
 FOUNTAIN: 24" (610mm)  
 BUBBLER: 29-7/8" (756mm)
- ADULT WHEELCHAIR HEIGHT: SEE SHT 2 FIG 2  
 WASTE: 29-1/4" (743mm)  
 SUPPLY: 29-1/8" (740mm)  
 MOUNTING HOLE: 27-13/16" (706mm)  
 MOUNTING PLATE: 26-3/16" (665mm)  
 FOUNTAIN: 27" (686mm)  
 BUBBLER: 32-7/8" (832mm)

- STANDING ADULT HEIGHT: SEE SHT 2 FIG 3  
 WASTE: 34-3/4" (883mm)  
 SUPPLY: 34-5/8" (879mm)  
 MOUNTING HOLE: 33-5/16" (846mm)  
 MOUNTING PLATE: 31-1/16" (805mm)  
 FOUNTAIN: 32-1/5" (826mm)  
 BUBBLER: 38-3/8" (972mm)

Available with hands off sensor  
 in lieu of push button valve.

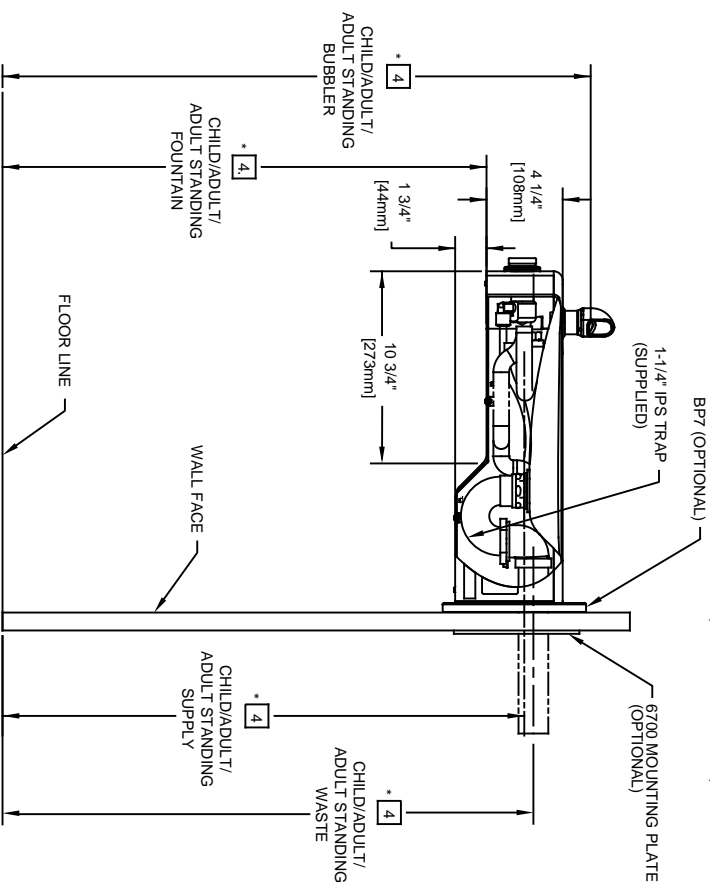
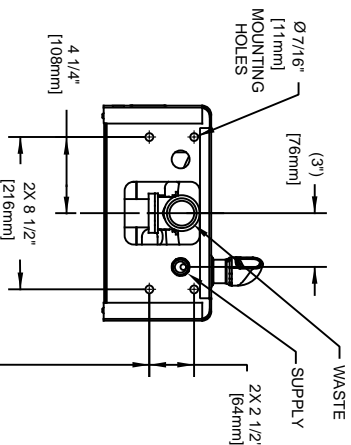
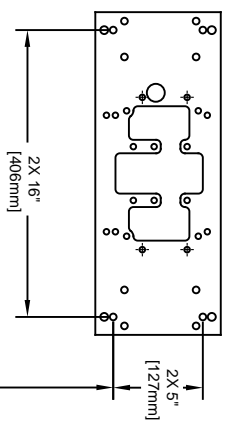
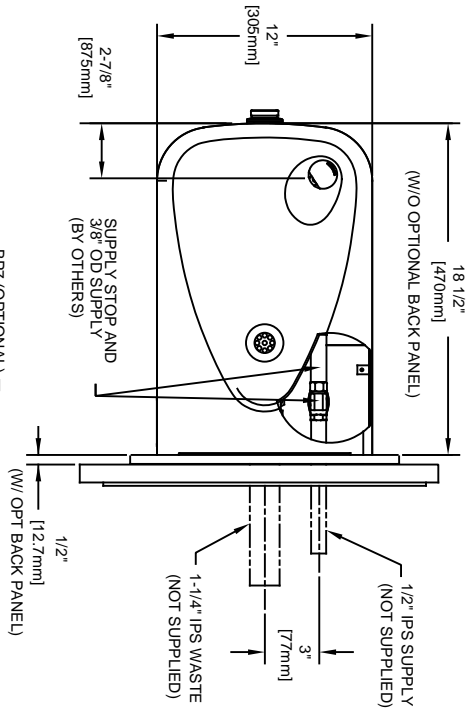
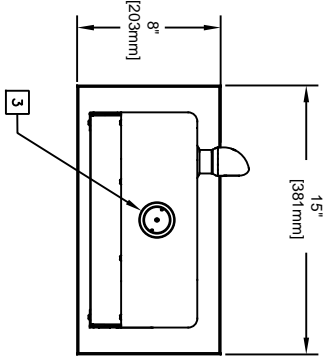

**MOUNTING DETAIL**  
 BACK VIEW

**MOUNTING PLATE**  
 (OPTIONAL, HAWS 6700)

1456 KLEPPE LANE  
 SPARKS, NEVADA, 89431  
 (775) 359-4712 FAX (775) 359-7424  
 E-MAIL: HAWS@HAWS.CO.COM  
 WEBSITE: WWW.HAWS.CO.COM

ECN NO. REVISED PER BY: MODEL(S)  
 ECN: 5215 JP  
 DATE: 10/25/06 GC  
 DRAWN: DATE: CHKD:  
 C.FENNER: 10/25/06 GC  
 APPROVED: DATE: SCALE: 1:1 DRAWING TYPE: INSTALLATION  
 FV: 11/21/17

1107L/1107LHO

PART NUMBER: 0002080232.D  
 REVISION: 15

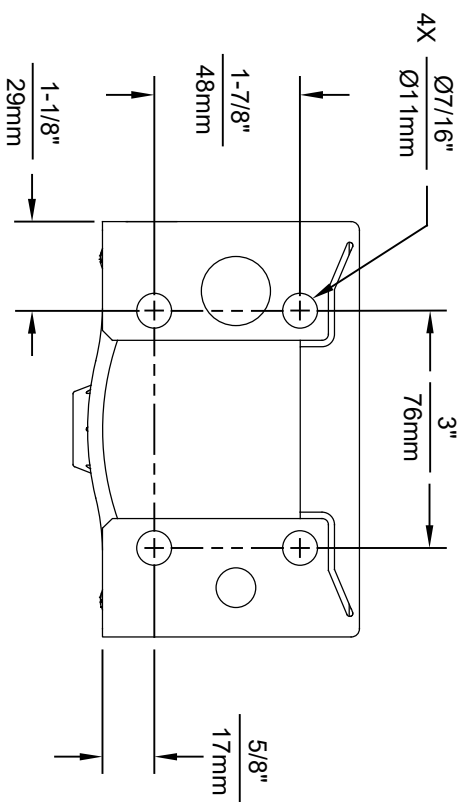
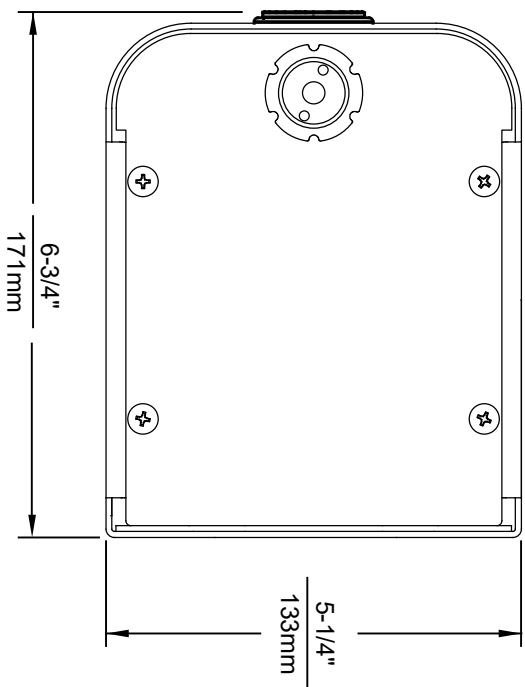
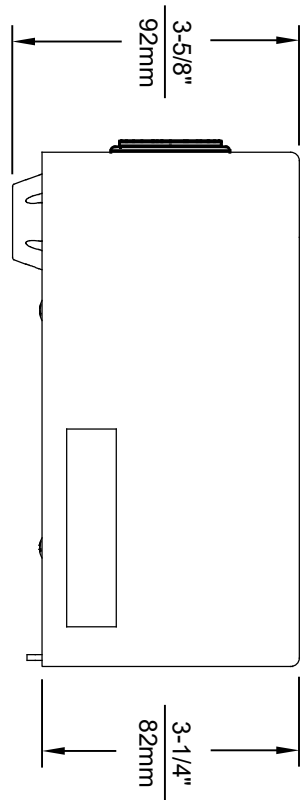

1920HO SERIES MOUNTING HOLE LOCATIONS  
(3/8" - 16 UNC MOUNTING HARDWARE NOT SUPPLIED)

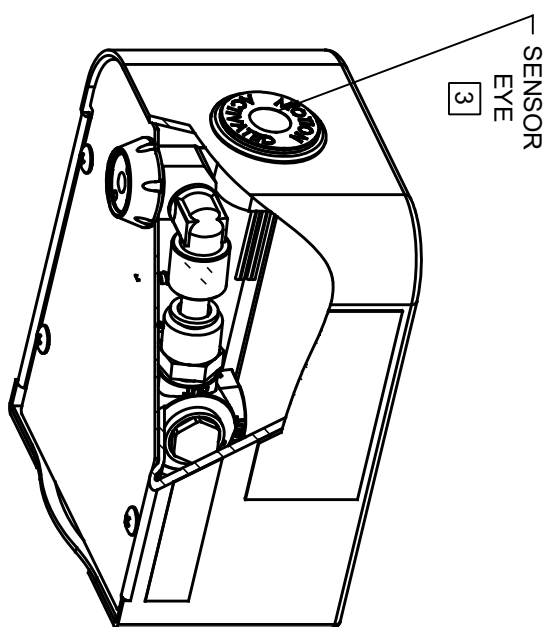

NOTES:

1. SEE SEPARATE INSTALLATION DRAWINGS FOR MOUNTING PLATES AND BACKPANELS
2. WHEN INSTALLING THIS UNIT, LOCAL, STATE OR FEDERAL CODES SHOULD BE ADHERED TO FOR INSTALLATION LOCATIONS, WASTE AND SUPPLY REQUIREMENTS OTHER THAN SHOWN.
3. REFER TO 1RKHO.H OPERATION & MAINTENANCE INSTRUCTIONS FOR SENSOR SETUP.



1455 KLEPPE LANE  
SPARKS, NEVADA 89431  
(775) 359-4712 FAX (775) 359-7424  
E-MAIL: HAWS@HAWSCCO.COM  
WEBSITE: WWW.HAWSCCO.COM

EQ. NO. REVISION	PER. BY	DATE	SCALE	INSTALLATION	SIZE	SHEET
0510001063.D	B.M.	05/19/21	N/A		A	1 OF 6
REV. NO.	DATE	BY	SCALE	INSTALLATION	SIZE	SHEET
4	05/19/21	B.M.	N/A		A	1 OF 6

THIS DOCUMENT IS TRUE AND CORRECT AT TIME OF PUBLICATION. CONTINUED PRODUCT IMPROVEMENTS MAKE SPECIFICATIONS AND MEASUREMENTS SUBJECT TO CHANGE WITHOUT NOTICE.

6700 MOUNTING PLATE  
(BEHIND FINISH WALL)  
- OR -  
6700R RETROFIT PLATE  
(ON TOP OF FINISH WALL)

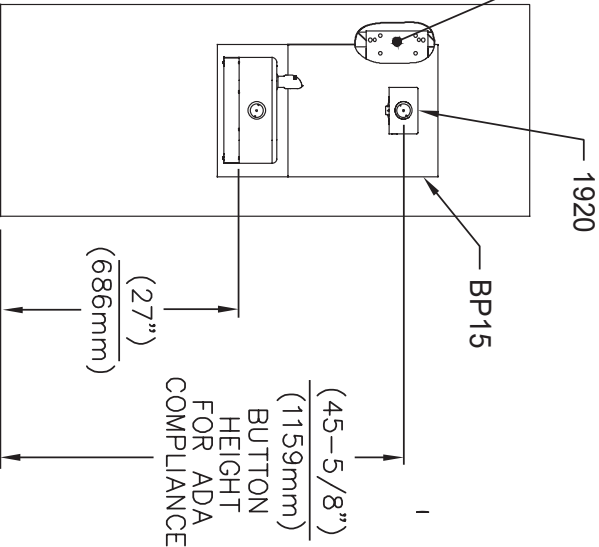

INSTALLATION ABOVE HAWS 1107L



3/8" PUSH IN TEE  
(CONNECT TO  
FOUNTAIN SUPPLY)

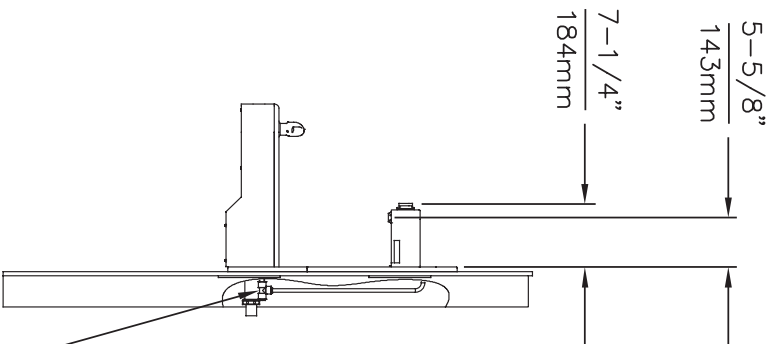

\* IF YOUR FOUNTAIN IS THIS STYLE USE THESE DIMENSIONS

1. SEE SEPARATE INSTALLATION DRAWINGS FOR MOUNTING PLATES AND BACKPANELS
2. WHEN INSTALLING THIS UNIT, LOCAL, STATE OR FEDERAL CODES SHOULD BE ADHERED TO FOR INSTALLATION LOCATIONS, WASTE & SUPPLY REQUIREMENTS OTHER THAN SHOWN.

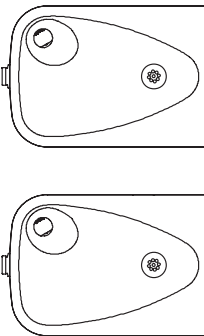

1455 KLEPPPE LANE  
SPARKS, NEVADA 89431  
(775) 359-4712 FAX (775) 359-7424  
E-MAIL: HAWS@HAWS.CO.COM  
WEBSITE: WWW.HAWS.CO.COM

ECONO. REVISED PERBY:	MODEL(S)	MODEL 1107L
DRAWING:	EN. DATE:	CHGO
SCC:	DATE:	08/13/17
APPROVED:	SCALE:	NA
	DRAWING TYPE:	INSTALLATION
	SIZE:	A 1 SHEET 1 OF 2
	PART NUMBER:	1107L-20
	REVISION:	0A.1
	WITH MODEL:	1920 BOTTLE FILLER

©2017 Haws Corporation - All Rights Reserved. HAWS® and other trademarks used in these materials are the exclusive property of Haws Corporation.

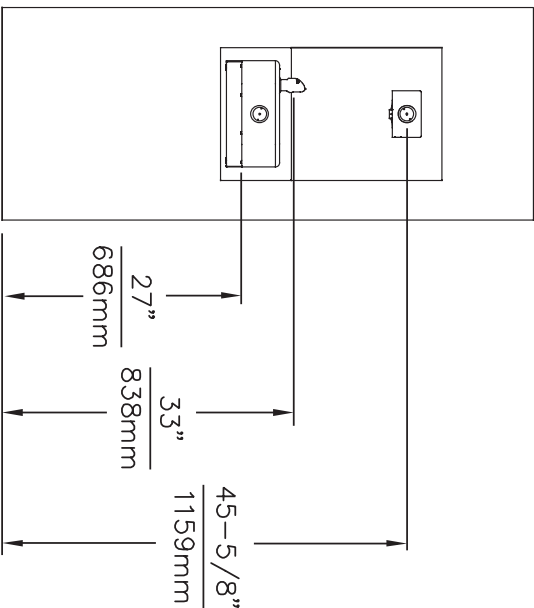

**ADA ADULT ACCESSIBLE DIMENSIONS 1107L AND H1107.8**  
H1107.8 GRILL NOT SHOWN FOR CLARITY

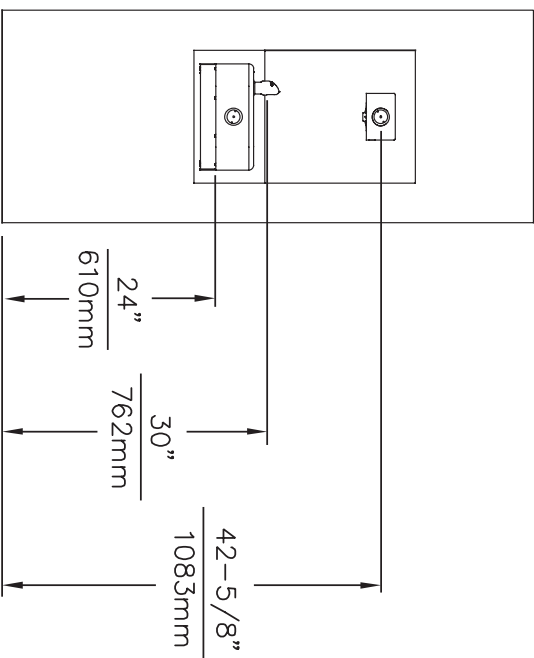

**ADA CHILD ACCESSIBLE DIMENSIONS 1107L AND H1107.8**  
H1107.8 GRILL NOT SHOWN FOR CLARITY

		<b>Haws</b>		1485 KLEPPE LANE	
SPARKS, NEVADA 89431		(775) 359-4712 FAX (775) 359-7424		EMAIL: HAWS@HAWSCO.COM	
WEBSITE: WWW.HAWSCO.COM		ECON. NO. REVISED PER BY:		MODEL(S)	
DRAWN	EQX	DATE	CHKD.	MODEL 1107L AND H1107.8	
APPROVED	DATE	DATE		WITH MODEL 1920 BOTTLE FILLER	
SCALE: N/A		DRAWING TYPE:		INSTALLATION	
SIZE: A		SHEET: 1 OF 1		PART NUMBER	
				1107L-24	
				REVISION	
				0A.1	