



model H1117LN.8-1920

ADA Low Profile Chilled Vandal-Resistant Fountain and Bottle Filler

FEATURES & BENEFITS

ADA COMPLIANCE

ADA-compliant bottle filling station and dual-height high low drinking fountain required for wheel chair use, and for the standing person.

CONSTRUCTION

One-piece drinking fountains with low-profile design made of 14 gauge Type 304 stainless steel with 1/4" (.6 cm) thick stainless back plates welded in, and vandal-resistant stainless bottom plates.

MOUNTING

In-wall mounting frame is made of 16 gauge galvanized steel with welded-in heavy-duty 10 gauge mounting plate with pre-punched mounting holes. Further convenience is given to the chiller with the integral fold-out shelf.

BUBBLER HEADS

Polished chrome-plated brass bubbler head with integral 11/16" dia. basin shank and stainless anti-rotation roll pin for vandal resistance strength. Shielded, angled stream opening provides a steady, sanitary source of drinking water at .45 gpm

PUSH BUTTON VALVES

The push-button activated valves have all stainless steel bodies, with chrome plated brass push button assemblies which allow for front access to water stream adjustment, water control cartridge, and water supply strainer replacement without having to go through the bottom plate. Operating pressure range of 30 to 90 psi (2.1 to 6.2 bar).

BOTTLE FILLER

Vandal-resistant, 14-gauge Type 304 stainless steel bottle filler housing with push button operation and 1 gpm (3.78 L) laminar flow.

VANDAL-RESISTANT

The bubbler heads, push buttons, drain strainers and bottom plates are locked in place, discouraging unwanted vandal tampering.

OPTIONS

Mounting Plate: Model 6700, in-wall mounting plate for model 1920.

Mounting Plate: Model 6700R, on-wall mounting plate for model 1920.

Water Filter: Model 6426, 12" x 2" (30.5 x 5.1 cm), in-line lead removal element that reduces lead from incoming water supply.

Custom Logo Panel: Standard Model 6475 comes with "Hydration By Haws™" logo. Customize the panel with your choice of logo, slogan, or graphic. For customization, call 888-640-4297. cane detection for the Haws Hi-Lo drinking fountains.



REQUIRED MODELS

H1117LN.8 / HCR8 / MTGFR.LG / 1920 / BP32

Order these items to make up the Model H1117LN.8-1920 fountain with stainless steel back panel, bottle filler with stainless steel back plate, and fountain mounting frame shown above.

SPECIFICATIONS

Model H1117LN.8-1920 electric vandal-resistant wall mounted ADA water cooler and bottle filler shall include dual 14 gauge Type 304 Stainless Steel satin finish basins, vandal-resistant push-button operated stainless steel valves with front-accessible cartridge, in-line strainer and flow adjustment, 100% lead-free waterways, 1 gpm (3.78L) laminar flow bottle filler, polished chrome-plated brass vandal-resistant bubbler heads, and polished chrome-plated vandal-resistant waste strainers. Unit shall also include vandal-resistant stainless bottom plates, stainless steel satin finish back panel and louvered intrusion-proof grille, high and low fountain mounting levels, and 1-1/4" NPT concealed all cast-brass traps. The patented design allows the unit to be mounted to meet ADA or Child ADA specifications. The R-134a refrigeration system is hermetically sealed and delivers a minimum of 8 gph (30.3 L) of water at 50° F (10° C) cooled from 80° F (26.7° C) inlet water at 90° F (32.2° C) ambient. 115 Volts, 60Hz, rated watts: 370, full load amps: 5 Manufactured to be lead-free by all known definitions including NSF/ ANSI/CAN 61-Section 9, NSF/ANSI/ CAN 372, California Proposition 65, and the Federal Safe Drinking Water Act. Product is compliant to California Health and Safety Code 116875 (AB 1953-2006), and NSF/ ANSI/CAN 61: Q ≤ 1.



NOTES:

1. HOLD ROUGH-IN DIMENSIONS $\pm 1/8"$ (3.2mm)
2. WHEN INSTALLING THIS UNIT, LOCAL, STATE, OR FEDERAL CODES SHOULD BE ADHERED TO. FOR INSTALLATION HEIGHTS OTHER THAN SHOWN, DIMENSIONS MARKED (*) MUST BE ADJUSTED ACCORDINGLY.
3. REFER TO MTG.FRLG INSTALLATION DRAWING FOR FRAME ROUGH-IN DIMENSIONS.
4. REFER TO 5874 SERIES OPERATION AND MAINTENANCE MANUAL FOR PUSH BUTTON AND VALVE INSTALLATION/MAINTENANCE INSTRUCTIONS.
5. ROUGH-IN DIMENSIONS FOR FOUNTAIN HEIGHTS:

ADULT WHEELCHAIR HEIGHT: SEE SHEET 2 FIG 2

WASTE: 29-1/4" (743mm)
FOUNTAIN: 27" (686mm)
BUBBLER: 32-7/8" (832mm)

ADULT STANDING HEIGHT: SEE SHEET 2 FIG 3

WASTE: 34-3/4" (883mm)
FOUNTAIN: 32-1/2" (826mm)
BUBBLER: 39-3/8" (972mm)

NOTES CONTINUED ON SHEET 2 OF 2

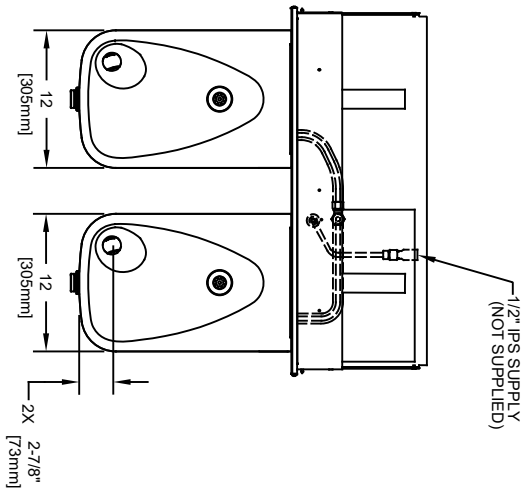

IMPORTANT: MOUNTING FRAME MUST BE INSTALLED SO THAT LIP OF FRAME SITS AGAINST FINISHED WALL FACE.

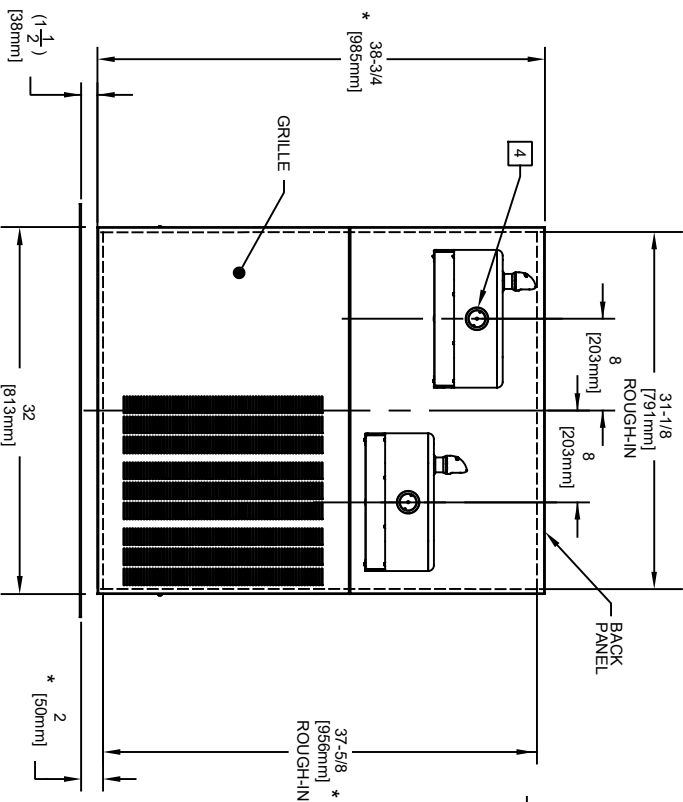
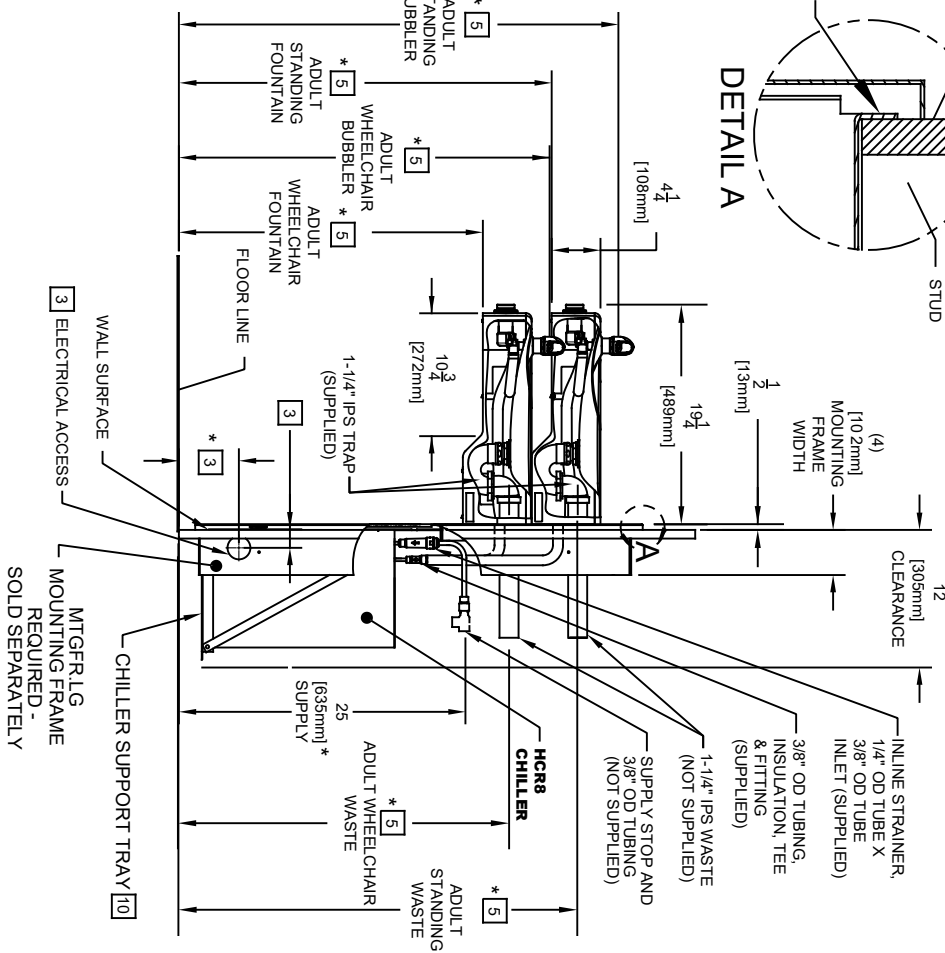
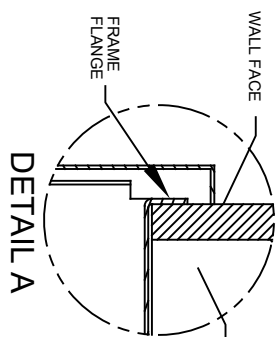

		MODEL(S)	
1456 KLEPPE LANE SPARKS, NEVADA, 89431 (775) 359-4712 FAX (775) 359-7424 E-MAIL: HAWWS@HAWSCO.COM WEBSITE: WWW.HAWSCO.COM		H11177LN 8	
ECN NO. REVISED PER BY:	DP	DATE:	SCALE: N/A
5871	DP	03/24/21	DRAWING TYPE:
DATE:	CHKD:	DATE:	INSTALLATION:
03/24/21	FV	06/21/21	SIZE: A
APPROVED:	DP	SCALE:	SHEET 1 OF 2
DP	DP		
PART NUMBER		REVISION	
0510001192.D		2	

NOTES:

- [6] USE SHADED HOLES TO MOUNT BOWLS AT INDICATED POSITIONS.
- 7. REFER TO SHEET 1 OF 2 NOTE 5, FOR INSTALLED FOUNTAIN DIMENSIONS.
- [8] INSERT 5/16"-18 PANEL NUT RETAINERS FROM OPPOSITE SIDE AT LOCATIONS INDICATED (SHOWN BY DARKENED HOLES). USE THE UPPER OUTERMOST HOLES ON THE LEFT AND LOWER OUTERMOST HOLES ON THE RIGHT.
- [9] TO INSERT OR REMOVE NUT RETAINERS: SNAP NUT RETAINERS INTO INDICATED LOCATIONS. IF REMOVAL IS REQUIRED, FIRST REMOVE SCREWS AND THEN SQUEEZE CLIPS ON NUT RETAINER TO POP OUT.
- [10] ALIGN HOLES IN CHILLER SUPPORT TRAY WITH HOLES IN FRAME AND FASTEN WITH #10 SHEETMETAL SCREWS (SEE SHEET 1).

NOTE: BACK PANEL MUST BE INSTALLED WITH THESE CUT-OUTS ORIENTED AS SHOWN.

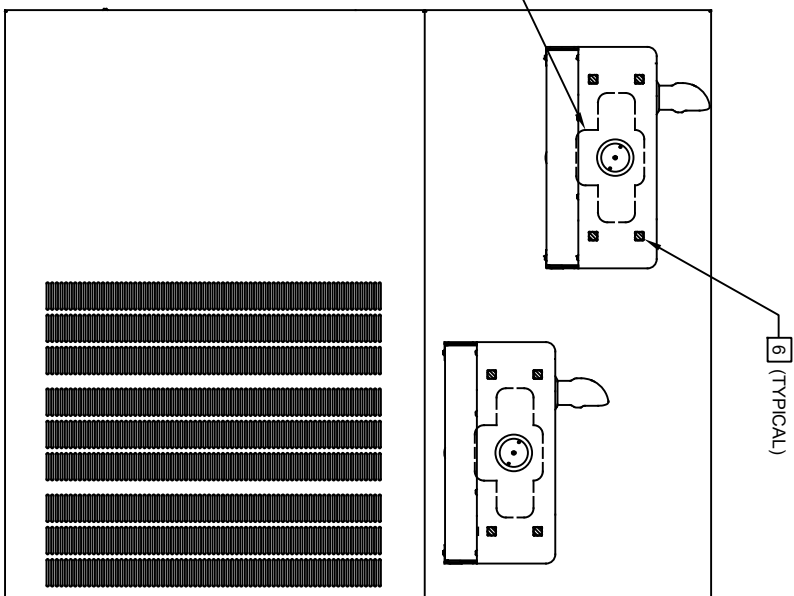

ADULT STANDING / ADULT WHEELCHAIR

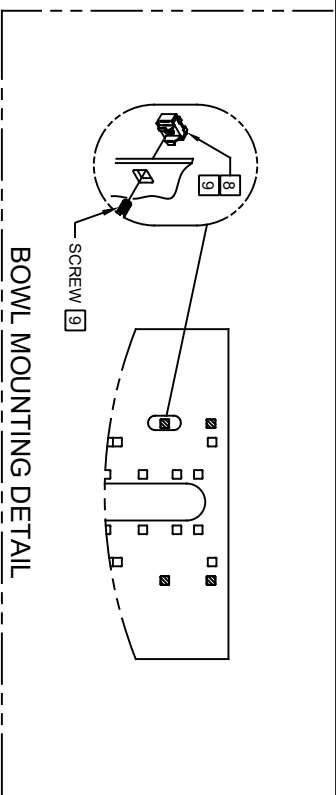

BOWL MOUNTING DETAIL

BOWL MOUNTING LOCATIONS

		Haws		1459 KLEPPE LANE SPARKS, NEVADA, 89431 (775) 359-4712 FAX (775) 359-7424 E-MAIL: HAWS@HAWSCO.COM WEBSITE: WWW.HAWSCO.COM	
ECN NO. REVISED PER BY:	MODEL(S)	H11177LN 8			
5671 ECN:5671 DP	DATE: 03/24/21	CHKD: EV	SCALE: N/A	DRAWING TYPE: INSTALLATION	SIZE: A
APPROVED: DP	DATE: 06/21/21	SCALE: N/A	DRAWING TYPE: INSTALLATION	SIZE: A	SHEET 2 OF 2
PART NUMBER 0510001192.D			REVISION 2		

THIS DOCUMENT IS TRUE AND CORRECT AT TIME OF PUBLICATION. CONTINUED PRODUCT IMPROVEMENTS MAKE SPECIFICATIONS AND MEASUREMENTS SUBJECT TO CHANGE WITHOUT NOTICE.

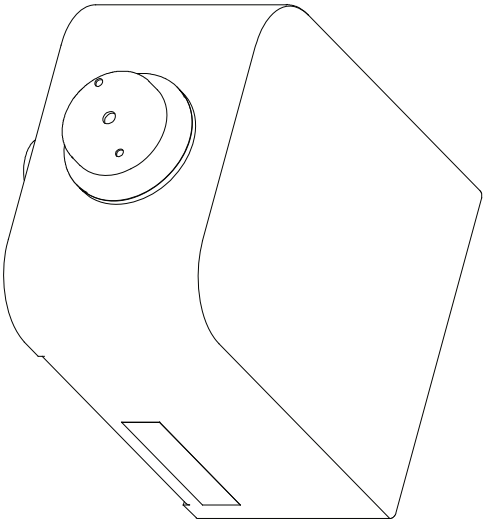
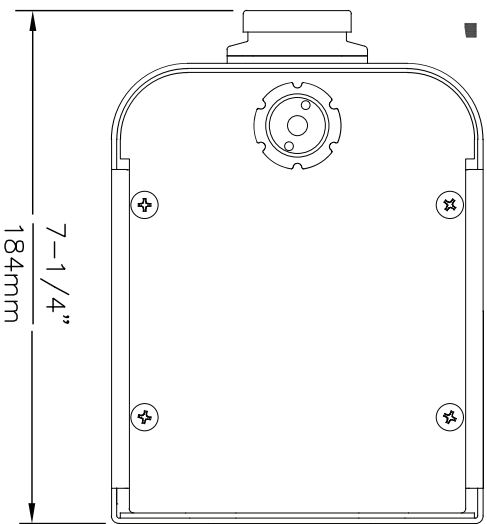
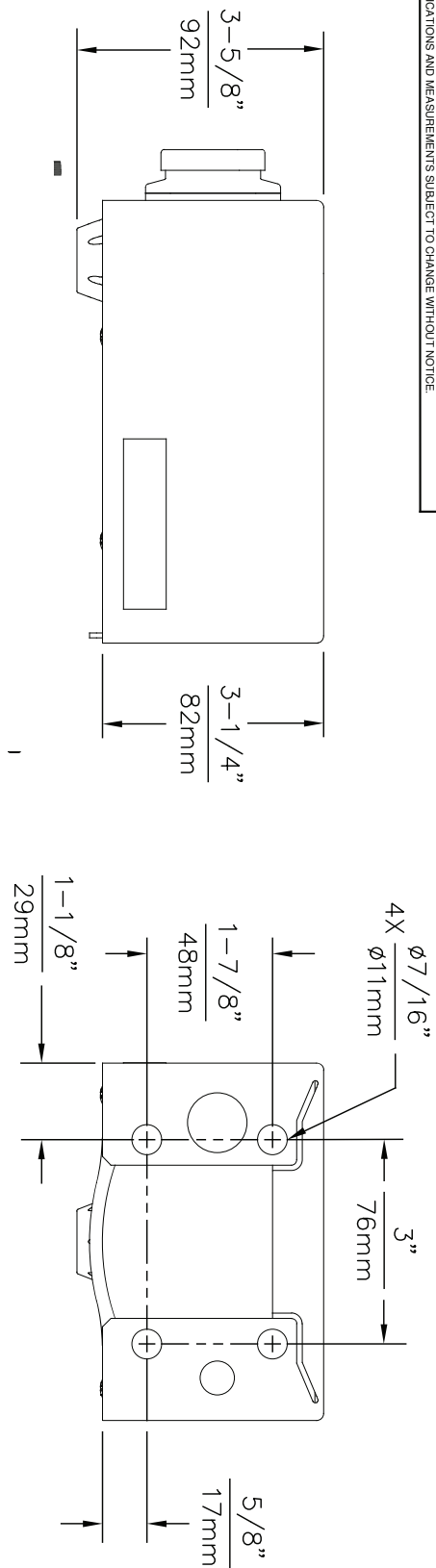

NOTES:

1. SEE SEPERATE INSTALLATION DRAWINGS FOR MOUNTING PLATES AND BACKPANELS
2. WHEN INSTALLING THIS UNIT, LOCAL, STATE OR FEDERAL CODES SHOULD BE ADHERED TO FOR INSTALLATION LOCATIONS, WASTE & SUPPLY REQUIREMENTS OTHER THAN SHOWN.

				1455 KLEPPE LANE SPARKS, NEVADA 89431 (775) 359-4712 FAX (775) 359-7424 E-MAIL: HAWS@HAWSCO.COM WEBSITE: WWW.HAWSCO.COM	
EON NO. 9081 DRAWN: DS APPROV: EV	REVISION PERBY: MJ DATE: 09/25/18 CHKD: EV	MODEL(S) MODEL 1920/1920HPS/1920W	SCALE: N/A DRAWING TYPE: INSTALLATION	SIZE: A SHEET: 1 OF 5	PART NUMBER REVISION 0510000490.D 2

©2017 Haws Corporation - All Rights Reserved. HAWS® and other trademarks used in these materials are the exclusive property of Haws Corporation.

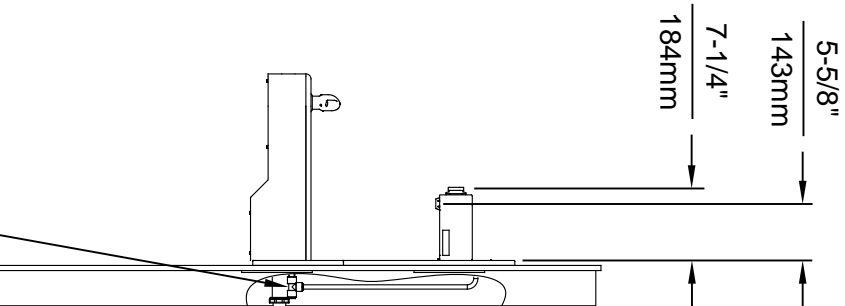
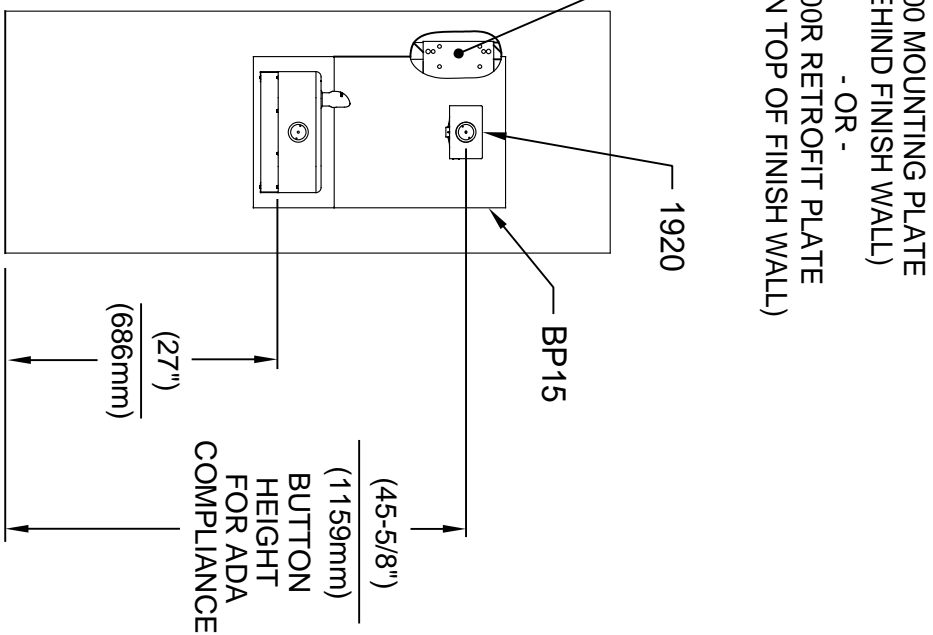
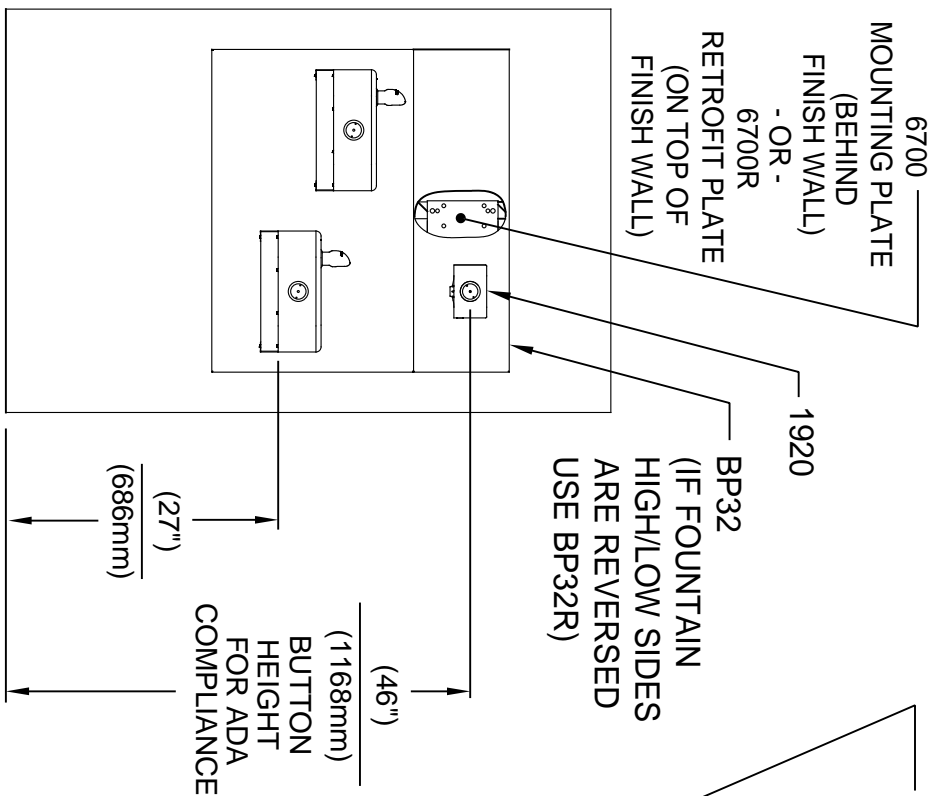

* IF YOUR FOUNTAIN IS THIS STYLE USE THESE DIMENSIONS



1. SEE SEPARATE INSTALLATION DRAWINGS FOR MOUNTING PLATES AND BACKPANELS
2. WHEN INSTALLING THIS UNIT, LOCAL, STATE OR FEDERAL CODES SHOULD BE ADHERED TO FOR INSTALLATION LOCATIONS, WASTE & SUPPLY REQUIREMENTS OTHER THAN SHOWN.



Haws

1456 KLEPPE LANE
SPARKS, NEVADA 89431
(775) 359-4712 FAX (775) 359-7424
E-MAIL: HAWS@HAWS.CO.COM
WEBSITE: WWW.HAWS.CO.COM

ECN NO. REVISED PER BY:	MODEL(S)	1920/1920HPS/1920W
5081	DATE:	01/20/17
MD	CHK'D:	SLS
APPROVED:	DATE:	08/13/20
EV	SCALE:	N/A
	DRAWING TYPE:	INSTALLATION
	SIZE:	A
	SHEET:	4 OF 6
	REVISION:	7
	PART NUMBER:	0510000490.D

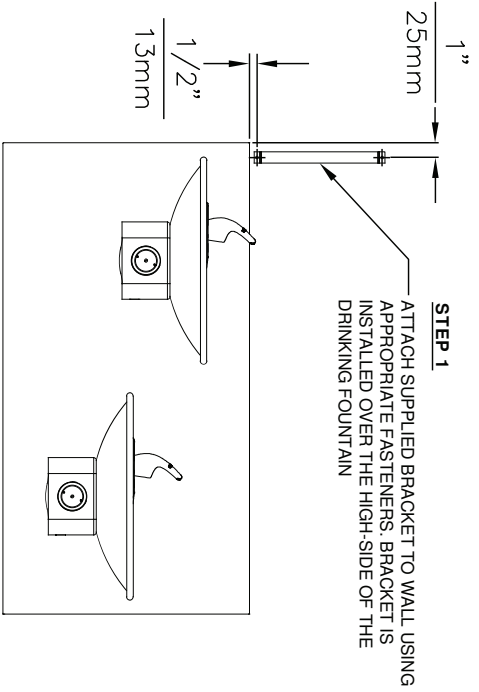

STEP 2
PLACE THE BACKPLATE AGAINST THE WALL AND SLIDE SIDEWAYS SO THE TABS CATCH UNDER THE BRACKET

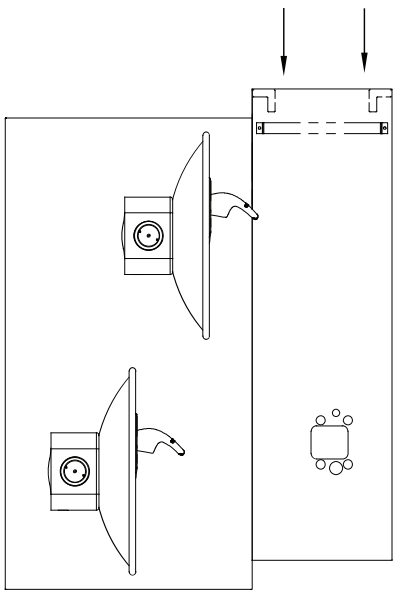

STEP 3
INSTALL THE BOTTLE FILLER PER THE INSTRUCTIONS SUPPLIED WITH THE UNIT

NOTES:
1. WHEN INSTALLING THIS UNIT, LOCAL, STATE OR FEDERAL CODES SHOULD BE ADHERED TO.

©2017 Haws Corporation - All Rights Reserved. HAWS® and other trademarks used in these materials are the exclusive property of Haws Corporation.

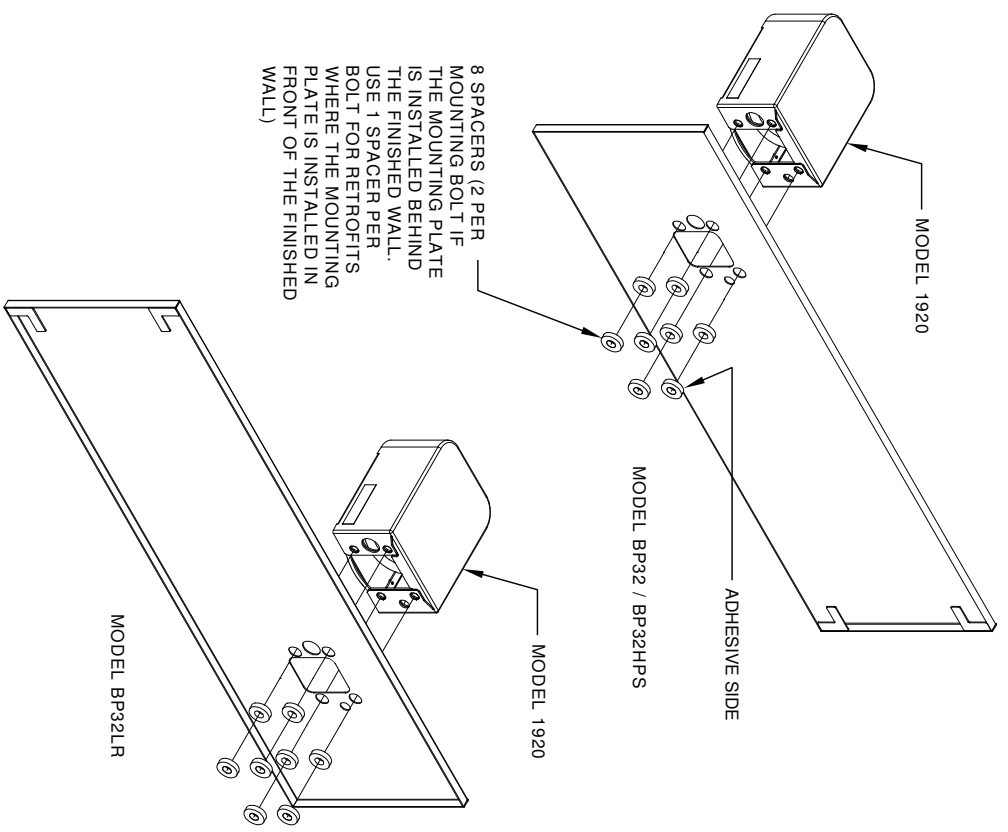

INSTALLATION OVER DOUBLE FOUNTAIN
SHOWN FROM REAR

		HAWS®	
1455 KLEPPE LANE SPARKS, NEVADA 89431 (775) 359-4712 FAX (775) 359-7424 E-MAIL: HAWS@HAWSCO.COM WEBSITE: WWW.HAWSCO.COM		MODEL(S) DRAWING: BACK PANEL SPACER INST. BF	
ECN NO: 5081	ECN: 5172	DATE: 10/20/17	DATE: 09/21/17
DRAWN: MJ	CHK'D: MJ	REV: 1	REV: 1
APPROVED: TV	SCALE: 1:1	DRAWING TYPE: INSTALLATION	SHEET: 2 OF 2
PART NUMBER: 0510000493.D		REVISION: 2	