

## FEATURES & BENEFITS

### CONSTRUCTION

Unit is made of 14 gauge Type 304 stainless steel with a white painted finish that resists stains and corrosion, and has soft rounded corners. Unit features vandal-resistant bottom plate and dispensing nozzle.

### BOTTLE FILLER VALVE

Fountain incorporates a touchless sensor operated stainless steel solenoid valve controlled by transformers for hands-free operation. A pressure regulator is used to adjust the bubbler flow according to incoming water pressures.

### LAMINAR FLOW

Adjustable, splash-free, 1 gpm (3.78 L) laminar water flow.

### EFFICIENT & FLEXIBLE INSTALLATION

Unit is designed for retrofit or new construction applications. No drain required for mounting over existing drinking fountain.

### MOUNTING OPTIONS

Select from mounting plate and back panel models to complete installation. Unit can mount on various wall types.

### VANDAL RESISTANT

The push button and bottom plate are locked in place, discouraging unwanted vandal tampering.



## OPTIONS

- Mounting Plate: Model 6700R on-wall mounting plate for model 1920WHO.
- Mounting Plate: Model 6700 in-wall mounting plate for model 1920WHO.
- Back Panel: Models BP15W white powder-coated stainless steel panel.
- Back Panel: Model BP8W white powder-coated stainless steel back panel.

For more information, visit [www.hawscow.com](http://www.hawscow.com) or call (888) 640-4297.

## SPECIFICATIONS

Model 1920WHO motion-activated wall mounted vandal-resistant bottle filler shall include 100% lead-free waterways, gloss white finish, stainless steel construction, 1 gpm (3.78 L) laminar flow, and touchless sensor operated stainless steel solenoid valve with 30-second obstruction time-out controlled by a transformer. It can be used as a stand-alone station, or mounted above the Haws® 1311 and 1501 drinking fountain models.

**This product requires a mounting plate; either the 6700 in-wall or the 6700R on-wall support plate. (See options below)**

**FOR INDOOR USE ONLY**

## APPLICATIONS

This type of wall mounted bottle filler may be placed in settings such as schools and other locations in and around office buildings, or with existing fountain installations where the temperature remains above freezing. Haws manufactures drinking fountains, faucets and electric water coolers to be lead-free by all known definitions including NSF/ANSI/CSA 61-Section 9, NSF/ANSI/CSA 372, California Proposition 65, and the Federal Safe Drinking Water Act. Product is compliant to California Health and Safety Code 116875 (AB 1953-2006), and 116876 (AB 100) "NSF/ANSI/CAN 61: Q ≤ 1".



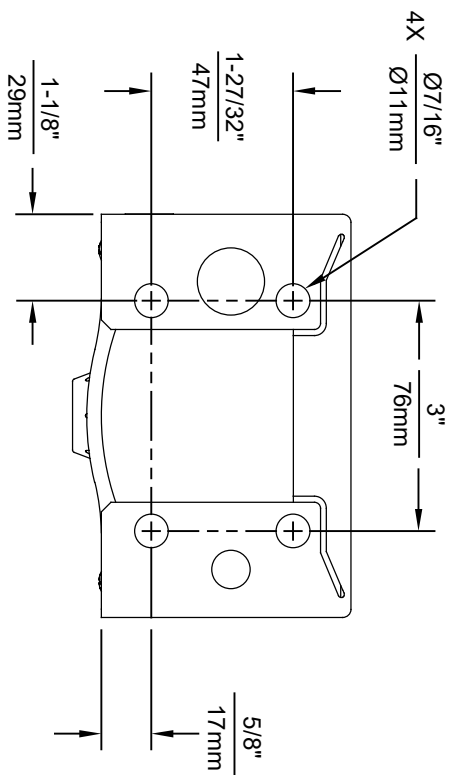
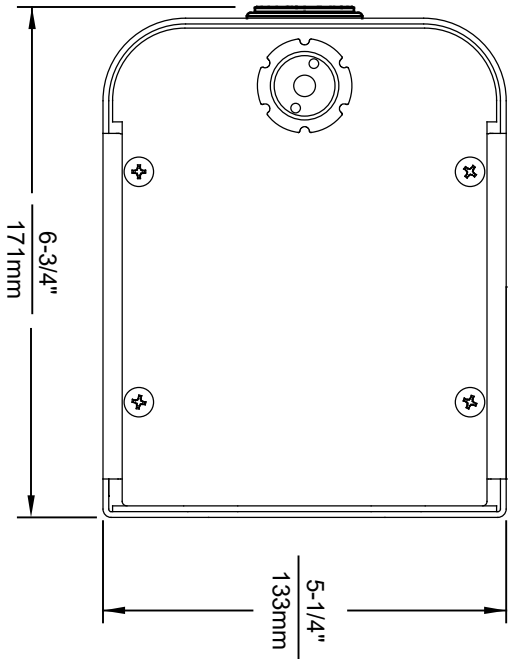
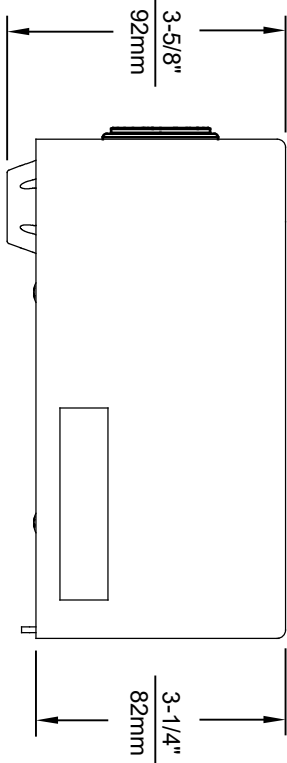

1920HO SERIES MOUNTING HOLE LOCATIONS  
(3/8" - 16 UNC MOUNTING HARDWARE NOT SUPPLIED)

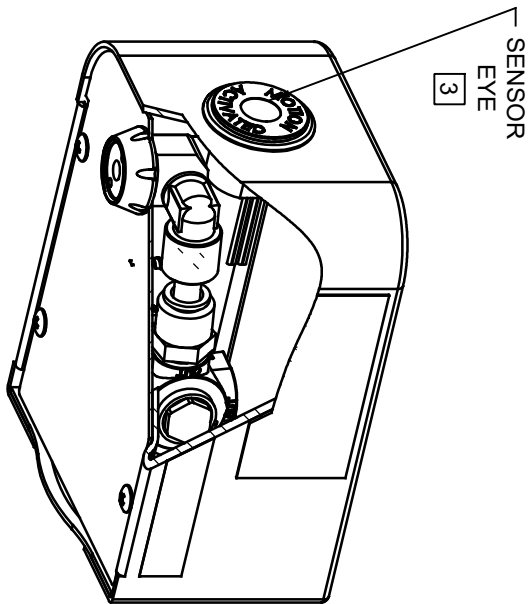

NOTES:

1. SEE SEPARATE INSTALLATION DRAWINGS FOR MOUNTING PLATES AND BACK PANELS (SHOWN FOR REFERENCE - NOT SUPPLIED).
2. WHEN INSTALLING THIS UNIT, LOCAL, STATE OR FEDERAL CODES SHOULD BE ADHERED TO FOR INSTALLATION LOCATIONS, WASTE AND SUPPLY REQUIREMENTS OTHER THAN SHOWN.
- 3 REFER TO 1RKHO.H OPERATION & MAINTENANCE INSTRUCTIONS FOR SENSOR SETUP.

		1455 KLEPPLE LANE SPARKS, NEVADA 89431 (775) 359-4712 FAX (775) 359-7424 E-MAIL: HAWS@HAWSCO.COM WEBSITE: WWW.HAWSCO.COM	
EGN NO: 5574 DRAWN: FV FV	REVISION PERMITS: ECN: 5883 DATE: 08/18/20 CHKD: KAN DATE: 09/06/23	MODEL(S) 1920HO/1920HPSHO/1920WHO	SCALE: N/A DRAWING TYPE: INSTALLATION SIZE: A1 SHEET: 1 OF 7
PART NUMBER 0510001063.D		REVISION: 6	

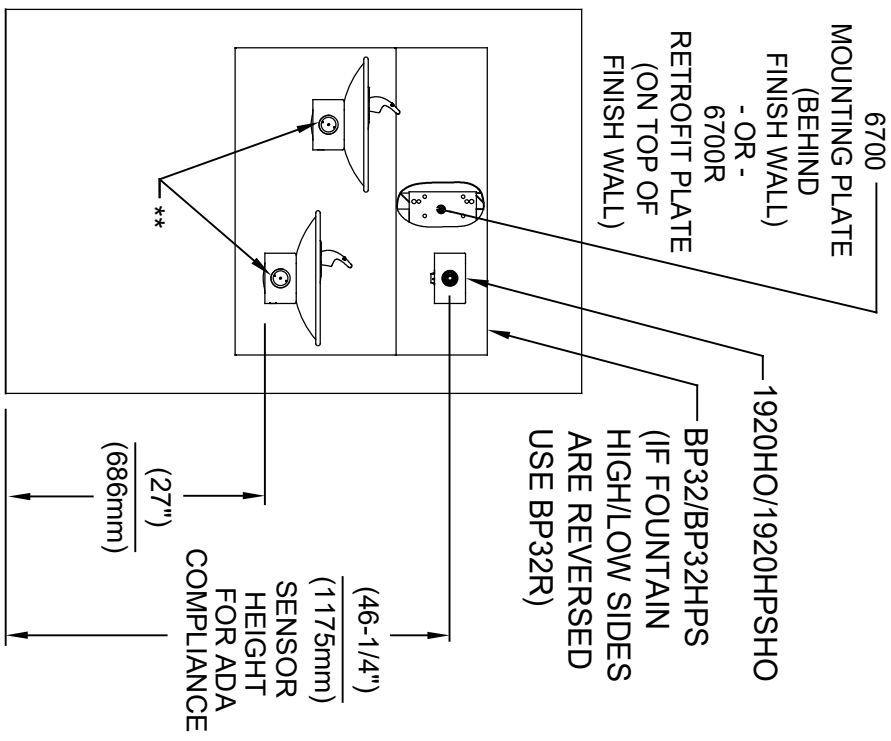

**INSTALLATION ABOVE HAWS 1011 & H1011.8 SERIES**

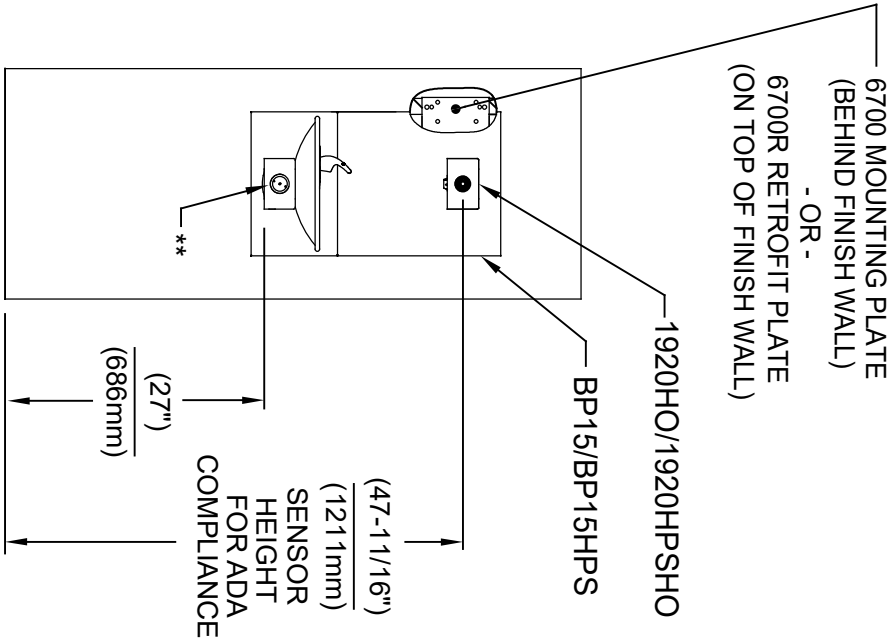

**INSTALLATION ABOVE HAWS 1001 & H1001.8 SERIES**

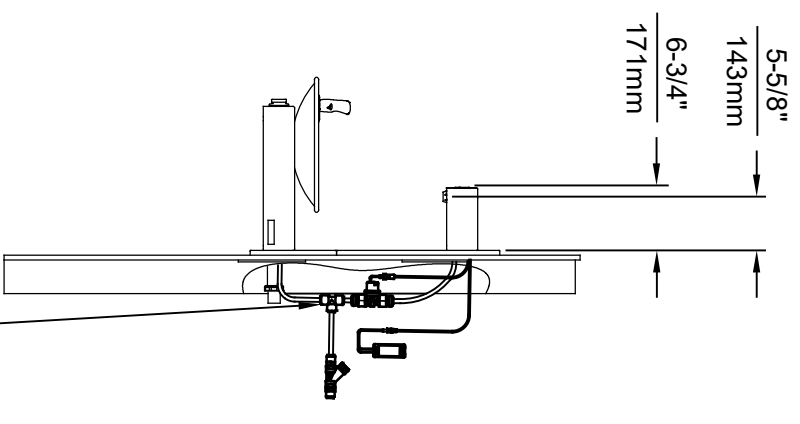

\* IF YOUR FOUNTAIN IS THIS STYLE USE THESE DIMENSIONS

1. SEE SEPARATE INSTALLATION DRAWINGS FOR MOUNTING PLATES AND BACK PANELS (SHOWN FOR REFERENCE - NOT SUPPLIED).
2. WHEN INSTALLING THIS UNIT, LOCAL, STATE OR FEDERAL CODES SHOULD BE ADHERED TO FOR INSTALLATION LOCATIONS, WASTE & SUPPLY REQUIREMENTS OTHER THAN SHOWN.

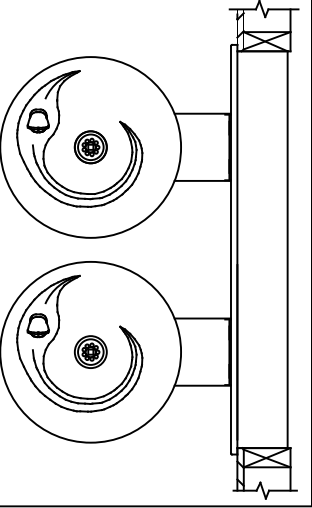

\*\* EXISTING PUSH BUTTON ASSEMBLY SHOWN, CAN BE CONVERTED TO HANDS OFF STYLE, USING RETRO-FIT KIT MODEL 1RKHO.H OR 2RKHO.H DEPENDING ON CUSTOMER REQUIREMENTS.

3/8" O.D. SUPPLY TUBING AND 3/8" O.D. PUSH-IN TEE SUPPLIED. (CONNECT TO FOUNTAIN SUPPLY LINE)



EQUIP. NO. REVISED PER BY:		MODEL(S)	
5574	ECN: 5883	1920HO/1920HPSHO/1920WHO	
DATE:	CHKD:	PART NUMBER	
08/18/20	KM	0510001063.D	
APPROVED:	DATE:	SCALE:	DRAWING TYPE:
FV	09/06/23	N/A	INSTALLATION
1455 KLEPPLE LANE		SIZE:	A1 SHEET 2 OF 7
SPARKS, NEVADA 89431			
(775) 359-4712 FAX (775) 359-7424			
E-MAIL: HAWS@HAWS.CO.COM			
WEBSITE: WWW.HAWS.CO.COM			
REVISION:		6	

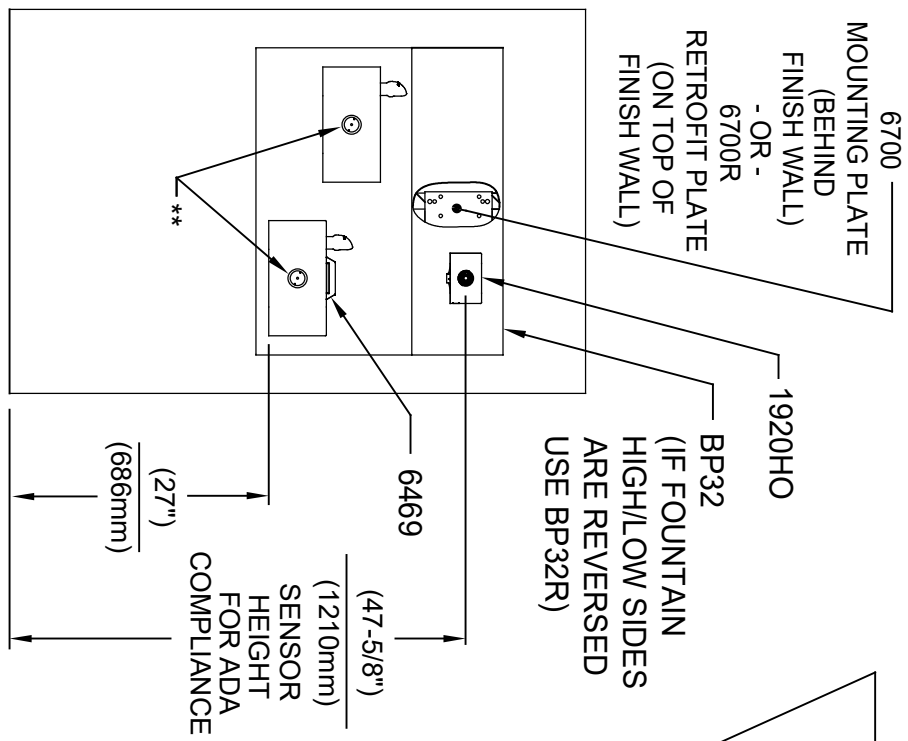

**INSTALLATION ABOVE HAWES 1119 & H1119.8 SERIES**

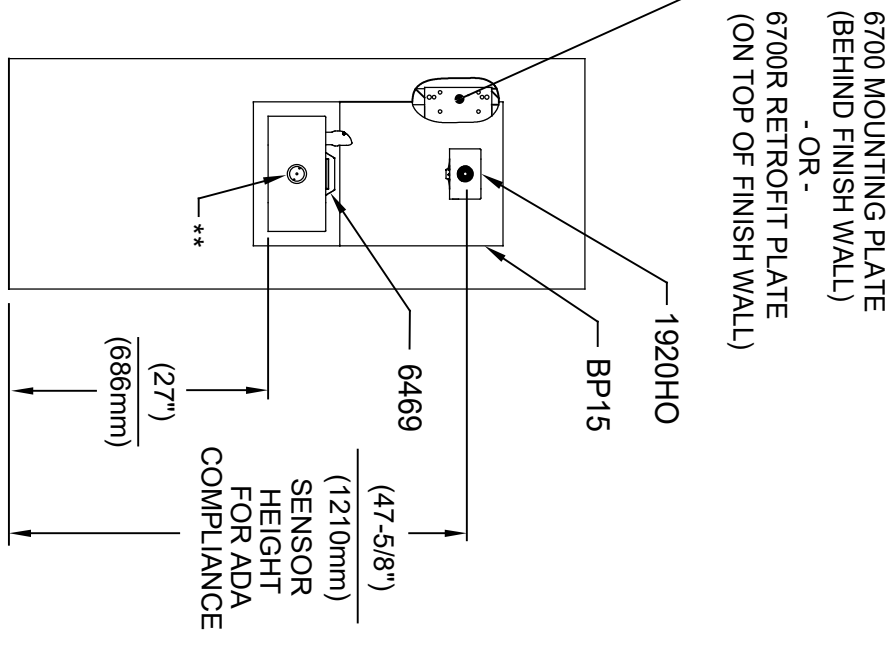

**INSTALLATION ABOVE HAWES 1109 & H1109.8 SERIES**

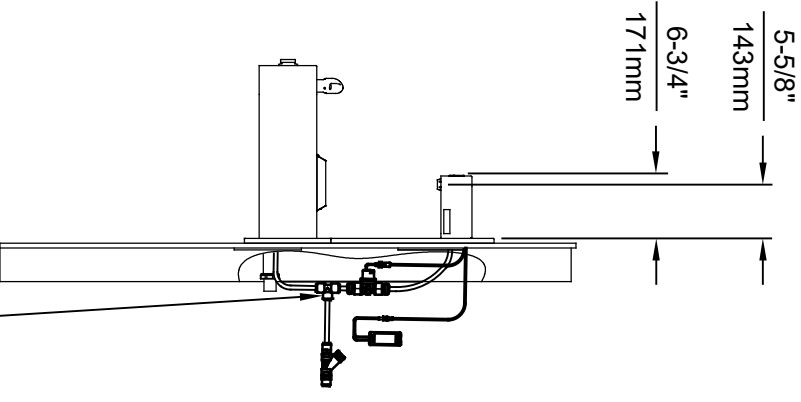

\* IF YOUR FOUNTAIN IS THIS STYLE USE THESE DIMENSIONS

1. SEE SEPARATE INSTALLATION DRAWINGS FOR MOUNTING PLATES, BACK PANELS AND DRIP TRAY (NOT SUPPLIED).

2. WHEN INSTALLING THIS UNIT, LOCAL, STATE OR FEDERAL CODES SHOULD BE ADHERED TO FOR INSTALLATION LOCATIONS, WASTE & SUPPLY REQUIREMENTS OTHER THAN SHOWN.

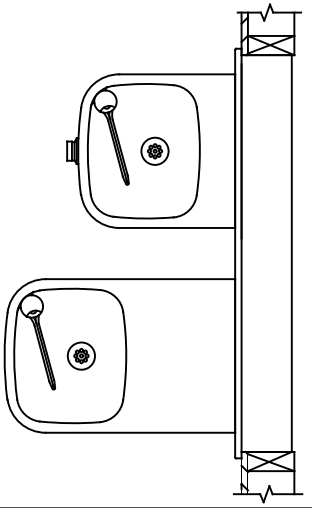

\*\* EXISTING PUSH BUTTON ASSEMBLY SHOWN, CAN BE CONVERTED TO HANDS OFF STYLE, USING RETRO-FIT KIT MODEL 1RKHO.H OR 2RKHO.H DEPENDING ON CUSTOMER REQUIREMENTS.

3/8" O.D. SUPPLY TUBING AND 3/8" O.D. PUSH-IN TEE SUPPLIED. (CONNECT TO FOUNTAIN SUPPLY LINE)

5-5/8"  
143mm  
6-3/4"  
171mm

1455 KLEPPER LANE  
SPARKS, NEVADA 89431  
(775) 359-4712 FAX (775) 359-7424  
E-MAIL: HAWS@HAWS.CO.COM  
WEBSITE: WWW.HAWS.CO.COM

ENGINEER	REVISED PER:	DATE	SCALE	W/A	DRAWING TYPE	INSTALLATION	SIZE	A1	SHEET	3	OF	7
5574	ECN: 5883	08/18/20				1920HO/1920HPSHO/1920WHO						
DRAWN:	DATE:	CHKD:										
FV		KM										
APPROVED:	DATE:											
FV	09/06/23											
MODEL(S)												
PART NUMBER												
0510001063.D												
REVISION												
6												

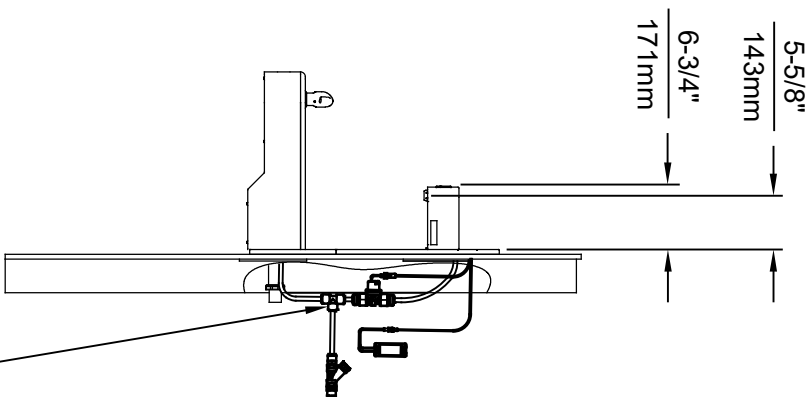
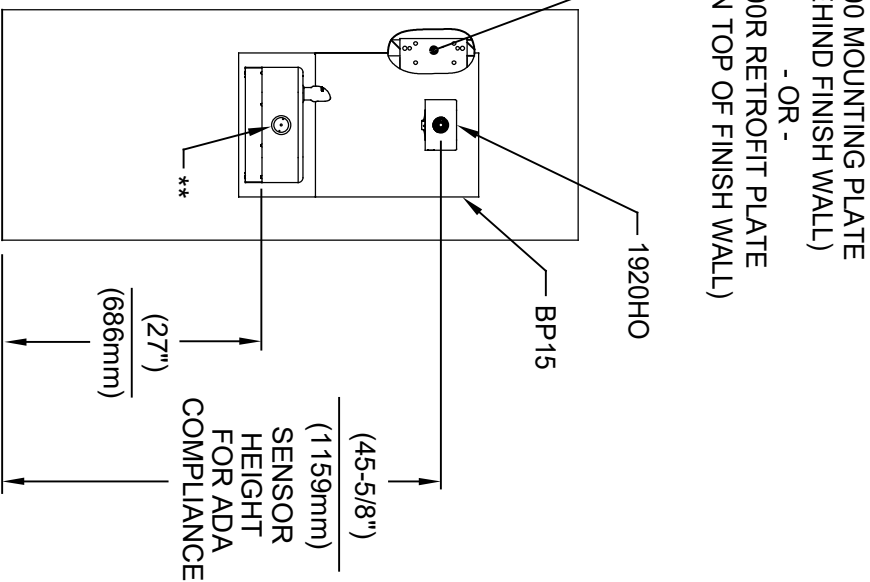
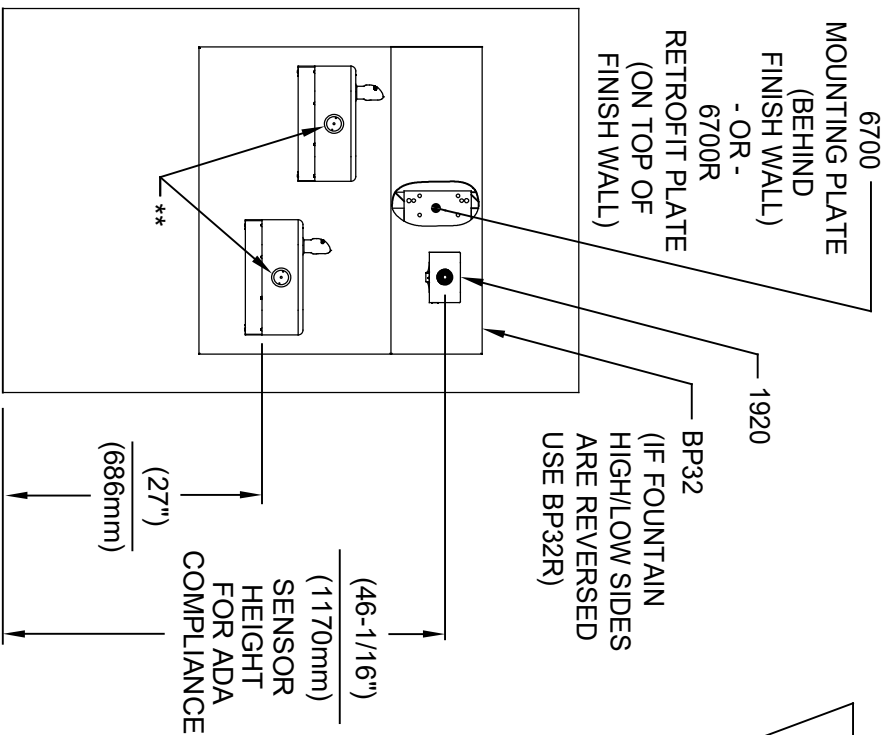

**INSTALLATION ABOVE HAWS 1117L (SHOWN), H1117.8 & HO SERIES (NOT SHOWN)**

\* IF YOUR FOUNTAIN IS THIS STYLE USE THESE DIMENSIONS

1. SEE SEPARATE INSTALLATION DRAWINGS FOR MOUNTING PLATES AND BACK PANELS (SHOWN FOR REFERENCE - NOT SUPPLIED).
2. WHEN INSTALLING THIS UNIT, LOCAL, STATE OR FEDERAL CODES SHOULD BE ADHERED TO FOR INSTALLATION LOCATIONS, WASTE & SUPPLY REQUIREMENTS OTHER THAN SHOWN.

**INSTALLATION ABOVE HAWS 1107L (SHOWN) & H1107.8 (NOT SHOWN)**

\*\* EXISTING PUSH BUTTON ASSEMBLY SHOWN, CAN BE CONVERTED TO HANDS OFF STYLE, USING RETRO-FIT KIT MODEL 1RKHO.H OR 2RKHO.H DEPENDING ON CUSTOMER REQUIREMENTS.

3/8" O.D. SUPPLY TUBING AND 3/8" O.D. PUSH-IN TEE SUPPLIED. (CONNECT TO FOUNTAIN SUPPLY LINE)

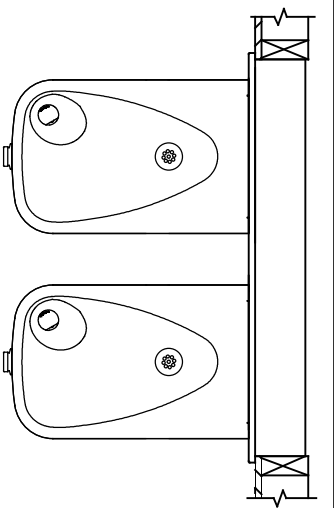

1455 KLEPPLE LANE

SPARKS, NEVADA 89431  
(775) 359-4712 FAX (775) 359-7424  
E-MAIL: HAWS@HAWSCO.COM  
WEBSITE: WWW.HAWSCO.COM

ENGINO	REVISED PER BY:	MODEL(S)	INSTALLATION
5574	ECN: 5893	1920HO/1920HPSHO/1920WHO	
DRAWN:	DATE:	CHKD:	
FV	08/18/20	KM	
APPROVED:	DATE:	SCALE:	DRAWING TYPE:
FV	09/06/23	N/A	
PART NUMBER	REVISION	SIZE:	SHEET:
0510001063.D	6	A	4 OF 7

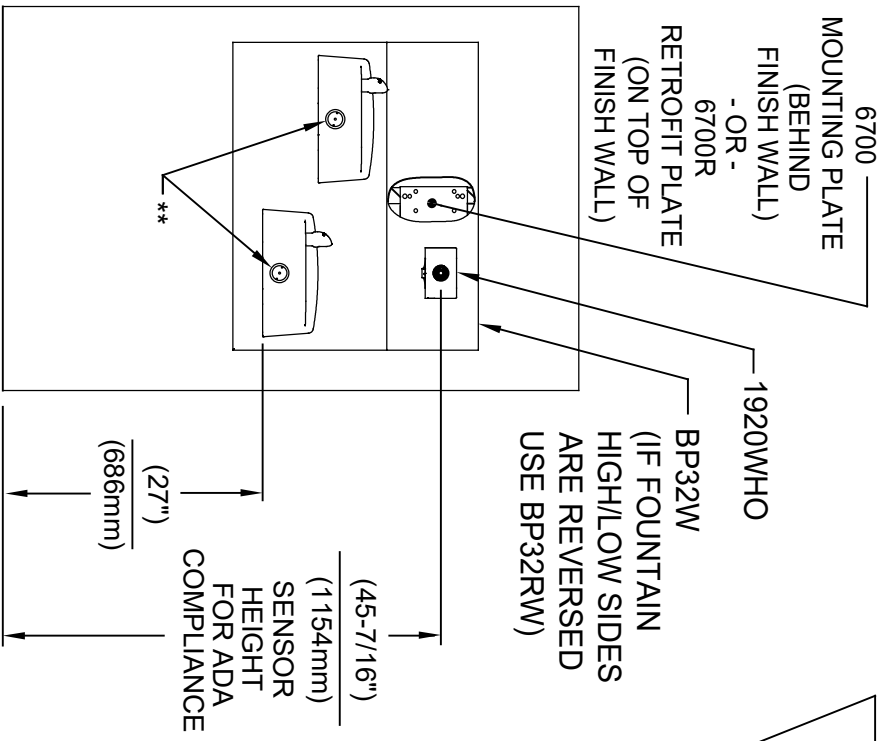

**INSTALLATION ABOVE HAWS 1501**

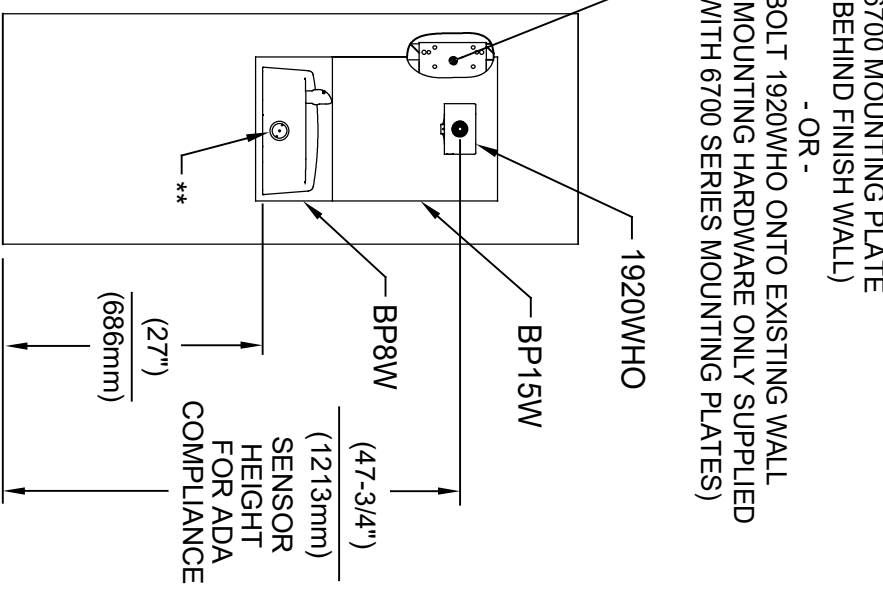

**INSTALLATION ABOVE HAWS 1311**

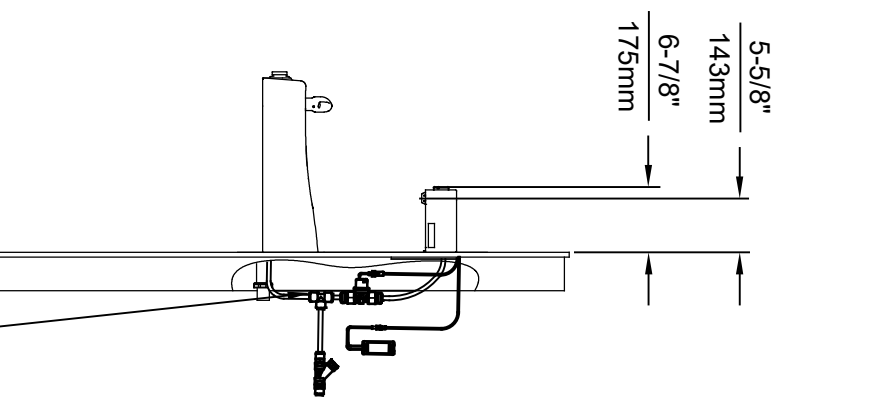

\* IF YOUR FOUNTAIN IS THIS STYLE USE THESE DIMENSIONS

1. SEE SEPARATE INSTALLATION DRAWINGS FOR MOUNTING PLATES AND BACK PANELS (SHOWN FOR REFERENCE - NOT SUPPLIED).
2. WHEN INSTALLING THIS UNIT, LOCAL, STATE OR FEDERAL CODES SHOULD BE ADHERED TO FOR INSTALLATION LOCATIONS, WASTE & SUPPLY REQUIREMENTS OTHER THAN SHOWN.

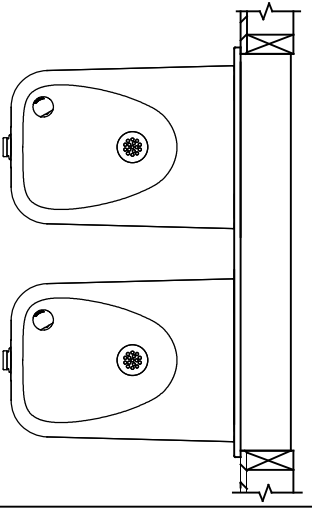

\*\* EXISTING PUSH BUTTON ASSEMBLY SHOWN, CAN BE CONVERTED TO HANDS OFF STYLE, USING RETRO-FIT KIT MODEL 1RKHO.H OR 2RKHO.H DEPENDING ON CUSTOMER REQUIREMENTS.

3/8" O.D. SUPPLY TUBING AND 3/8" O.D. PUSH-IN TEE SUPPLIED. (CONNECT TO FOUNTAIN SUPPLY LINE)



ENGINO	REVISED PER BY:	MODEL(S)	1455 KLEPPLE LANE
5574	ECN: 5893	1920HO/1920HPSHO/1920WHO	SPARKS, NEVADA 89431
DATE:	CHKD:		(775) 359-4712 FAX (775) 359-7424
08/18/20	KAM		E-MAIL: HAWS@HAWSCO.COM
APPROVED:	DATE:	SCALE:	WWW.HAWSCO.COM
FV	09/06/23	N/A	
		DRAWING TYPE:	INSTALLATION
		SIZE:	A1 SHEET 5 OF 7
		REVISION:	6
		PART NUMBER:	0510001063.D

6700 MOUNTING PLATE  
(BEHIND FINISH WALL)  
- OR -  
BOLT 1920HO ONTO EXISTING WALL  
(MOUNTING HARDWARE ONLY SUPPLIED  
WITH 6700 SERIES MOUNTING PLATES)

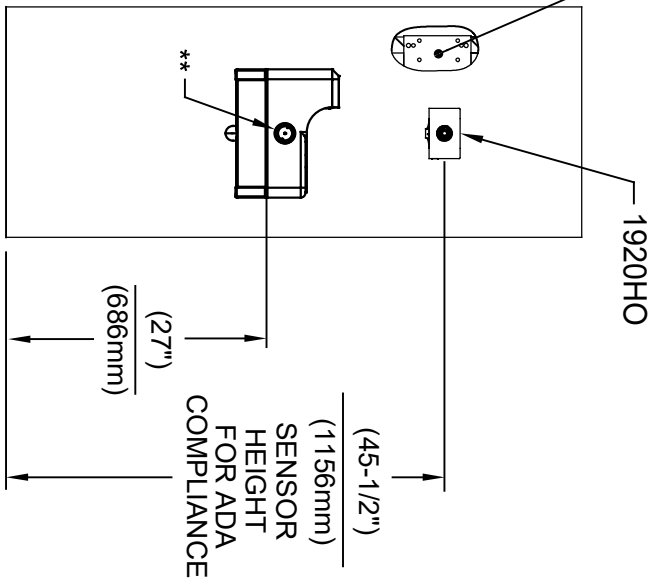

**INSTALLATION ABOVE HAWS 1047**

\* IF YOUR FOUNTAIN IS THIS STYLE USE THESE DIMENSIONS

1. SEE SEPARATE INSTALLATION DRAWINGS FOR MOUNTING PLATES AND BACK PANELS (SHOWN FOR REFERENCE - NOT SUPPLIED).
2. WHEN INSTALLING THIS UNIT, LOCAL, STATE OR FEDERAL CODES SHOULD BE ADHERED TO FOR INSTALLATION LOCATIONS, WASTE & SUPPLY REQUIREMENTS OTHER THAN SHOWN.

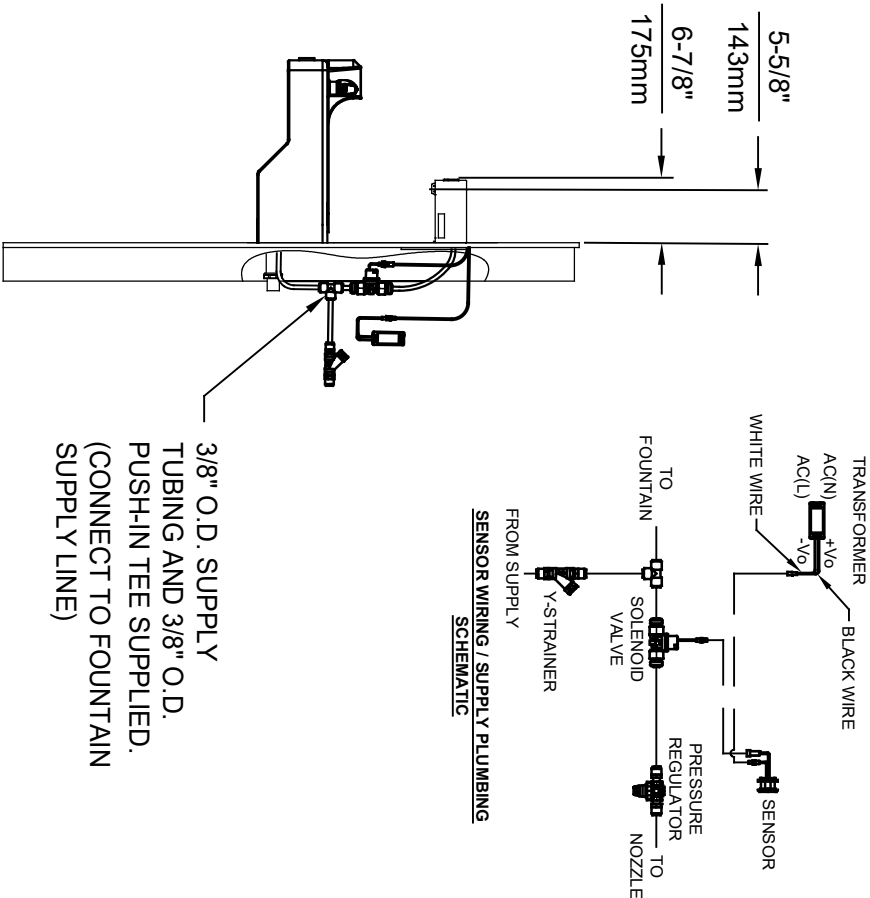
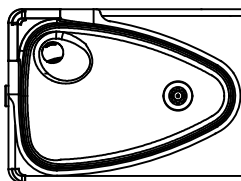
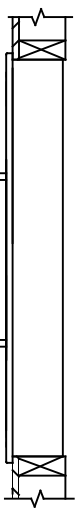

3/8" O.D. SUPPLY TUBING AND 3/8" O.D. PUSH-IN TEE SUPPLIED. (CONNECT TO FOUNTAIN SUPPLY LINE)

\*\* EXISTING PUSH BUTTON ASSEMBLY SHOWN, CAN BE CONVERTED TO HANDS OFF STYLE, USING RETRO-FIT KIT MODEL 1RKHO.H.



1455 KLEPPER LANE  
SPARKS, NEVADA 89431  
(775) 359-4712 FAX (775) 359-7424  
E-MAIL: HAWS@HAWS.CO.COM  
WEBSITE: WWW.HAWS.CO.COM

ENGINEER	REVISED PER	BY	DATE	SCALE	INSTALLATION
5574	ECN: 5893	FV	08/18/20	N/A	
DRAWN	DATE	CHKD	KAM		
FV					
APPROVED:	DATE	SCALE	N/A	DRAWING TYPE:	INSTALLATION
FV	09/06/23				
MODEL(S)	1920HO/1920HPSHO/1920WHO				
PART NUMBER	0510001063.D				
REVISION	6				
SIZE	A1 SHEET 6 OF 7				

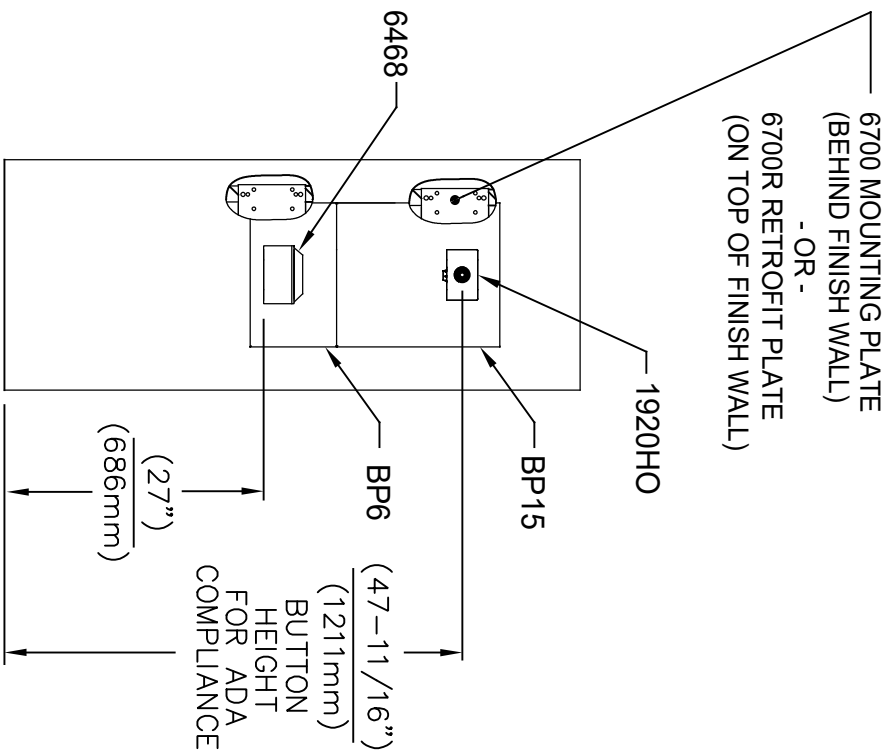

**INSTALLATION ABOVE 6468**

1. SEE SEPARATE INSTALLATION DRAWINGS FOR MOUNTING PLATES AND BACK PANELS (SHOWN FOR REFERENCE - NOT SUPPLIED).
2. WHEN INSTALLING THIS UNIT, LOCAL, STATE OR FEDERAL CODES SHOULD BE ADHERED TO FOR INSTALLATION LOCATIONS, WASTE & SUPPLY REQUIREMENTS OTHER THAN SHOWN.

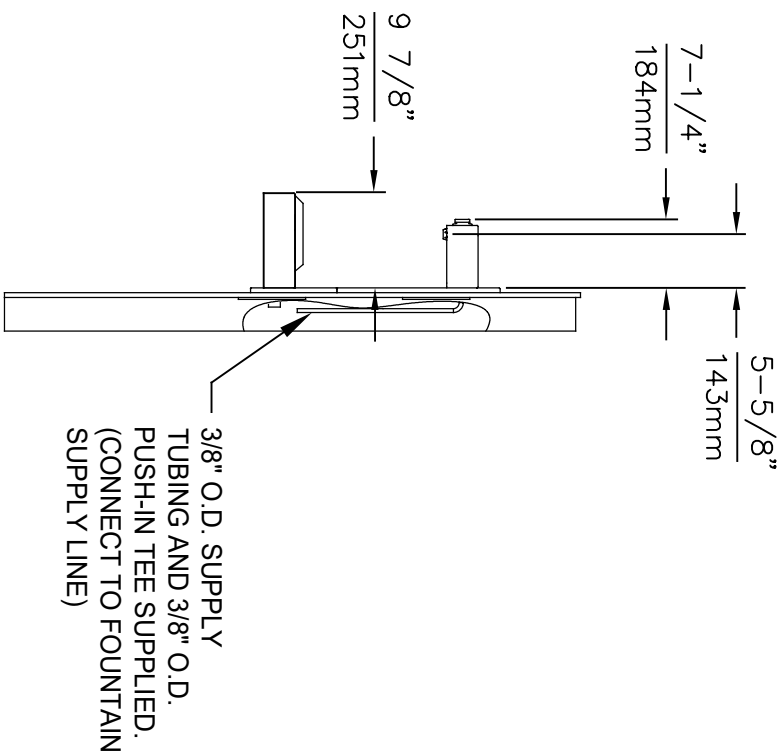

		1455 KLEPPLE LANE	
SPARKS, NEVADA 89431		(775) 359-4712 FAX (775) 359-7424	
E-MAIL: HAWS@HAWSCO.COM		WEBSITE: WWW.HAWSCO.COM	
EGN NO. REVISED PER BY: FV DRAWN: 5744 EGN: 5893 FV DATE: 10/04/21 CHKD: KM APPROVED: FV 09/06/23		MODEL(S) 1920HO/1920HPSHO/1920WHO	
SCALE: N/A		DRAWING TYPE: INSTALLATION	
SIZE: A1		SHEET: 7 OF 7	
PART NUMBER: 0510001063.D		REVISION: 6	