



# model 1109.14-1920

ADA Vandal-Resistant 14 Gauge Fountain and Bottle Filler

## FEATURES & BENEFITS

### CONSTRUCTION

Rugged ADA accessible 14-gauge Type 304 Stainless Steel with a satin finish bowl, 14 gauge Type 304 Stainless Steel bottle filler that resists stains and corrosion, soft rounded corners, stainless steel satin finish back panels, vandal resistant bottom plate, and 1-1/4" integral trap.

### BOTTLE FILLER

Vandal-resistant, 14-gauge Type 304 stainless steel bottle filler housing with push button operation and 1 gpm (3.78 L) laminar flow

### FOUNTAIN VALVES

The push-button activated valves have all stainless steel bodies, with chrome plated brass push button assemblies which allow for front access to water stream adjustment, water control cartridge, and water supply strainer replacement without having to go through the bottom plate. Operating pressure range of 30 to 90 psi (2.1 to 6.2 bar).

### BUBBLER HEAD

Polished chrome-plated brass bubbler head with integral 11/16" dia. basin shank and stainless anti-rotation roll pin for vandal resistance strength. Shielded, angled stream opening provides a steady, sanitary source of drinking water at .45 gpm.

### INTEGRATED TRAP

Brass 1-1/4" NPT trap is internally mounted for easy installation and access.

### VANDAL-RESISTANT

The bubbler head, push buttons, drain strainer and bottom plates are locked in place, discouraging unwanted vandal tampering.



## REQUIRED MODELS

### 1109.14 / 6469 / BP3 / 1920 / BP15

Order these items to make up Model 1109.14-1920 fountain with stainless steel back panel, bottle filler with stainless steel back plate, and drip tray drain.

## SPECIFICATIONS

Model 1109.14-1920 wall-mounted vandal-resistant ADA drinking fountain and bottle filler shall include an 14-gauge Type 304 Stainless Steel satin finish basin, 14 gauge Type 304 Stainless Steel bottle filler bracket, 100% lead-free waterways, vandal-resistant push-button operated stainless steel valves with front accessible cartridge and flow adjustment, polished chrome-plated brass vandal-resistant bubbler head, 1 gpm (3.78 L) laminar flow bottle filler, polished chrome-plated brass vandal-resistant waste strainer, vandal-resistant bottom plates, and 1-1/4" NPT trap. Manufactured to be lead-free by all known definitions including NSF/ ANSI/CAN 61-Section 9, NSF/ANSI/ CAN 372, California Proposition 65, and the Federal Safe Drinking Water Act. Product is compliant to California Health and Safety Code 116875 (AB 1953-2006), and NSF/ ANSI/CAN 61: Q ≤ 1.

## OPTIONS

Remote Drinking Fountain Water Chiller: Model HCR8, 8 gph (30.3 L) remote water chiller provides instantaneous cooling to meet a continuous demand for chilled water.

Mounting Plate: Model 6700, in-wall mounting plate for model 1920 and/or 1109.

Mounting Plate: Model 6700R, on-wall mounting plate for model 1920.

Support Frame: Model 6800 In-wall floor mounted fixture support legs, welded steel 4-bolt floor flanges, and supplied with 'U' bolts and hardware.

Custom Logo Panel: Standard Model 6475 comes with "Hydration By Haws™" logo. Customize the panel with your choice of logo, slogan, or graphic. For customization, call 888-640-4297.



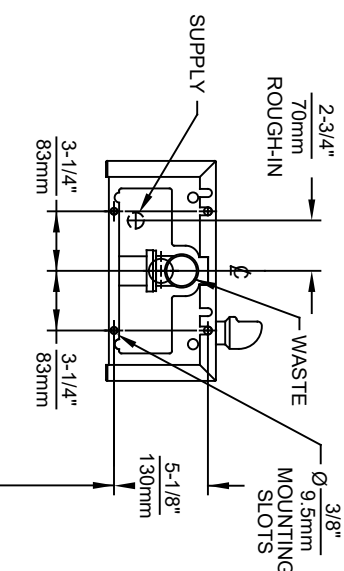
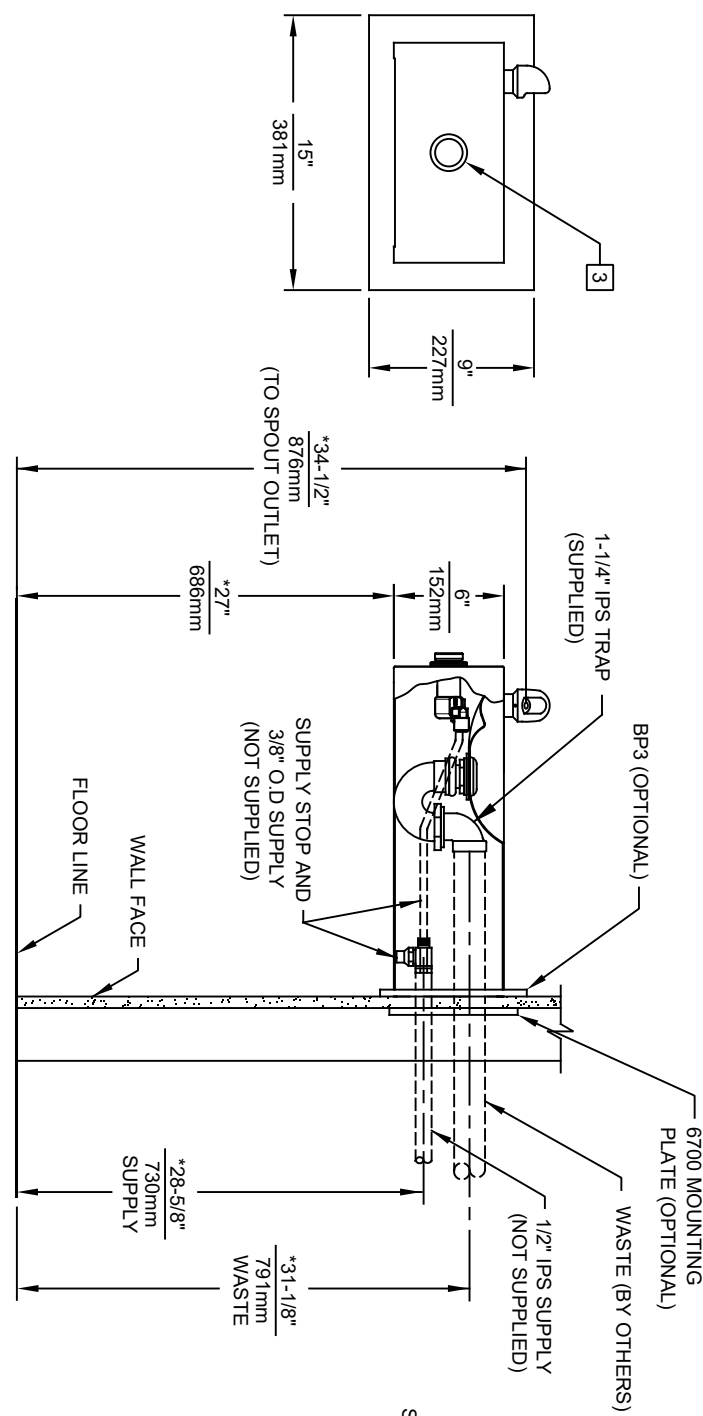
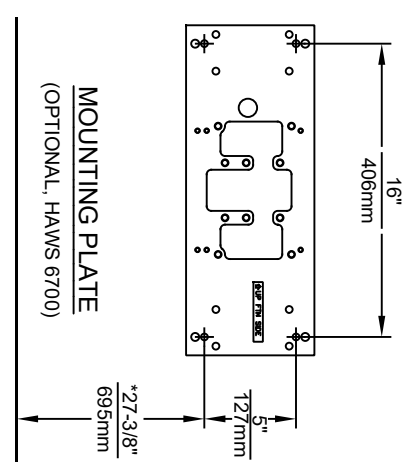
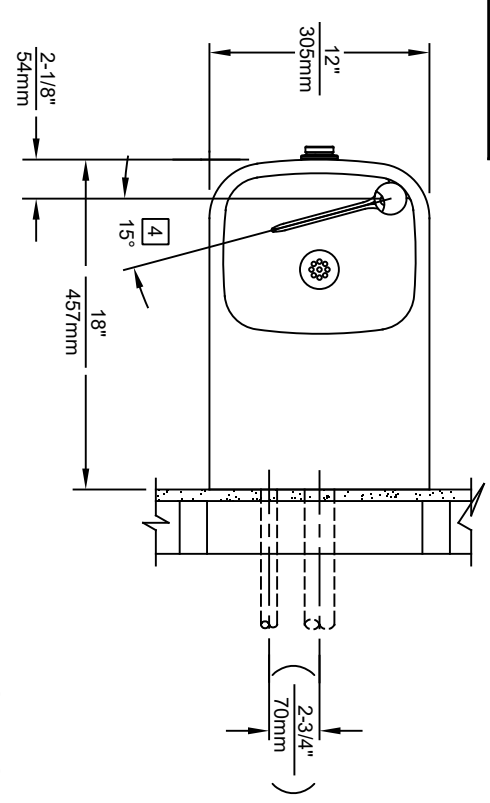

- NOTES:**
1. HOLD ROUGH-IN DIMENSIONS  $\pm 1/4"$  (6.4mm).

2. WHEN INSTALLING THIS UNIT, LOCAL, STATE OR FEDERAL CODES SHOULD BE ADHERED TO. FOR INSTALLATION HEIGHTS OTHER THAN SHOWN, DIMENSIONS MARKED (\*) MUST BE ADJUSTED ACCORDINGLY.

3. REFER TO 5874 SERIES/VRK5874 OPERATION AND MAINTENANCE MANUAL FOR PUSH BUTTON AND VALVE INSTALLATION AND MAINTENANCE INSTRUCTIONS.

4. MAXIMUM ADJUSTABLE RANGE IS 15° FROM PARALLEL TO BACK OF WALL.

**Haws**

1456 KLEPPE LANE  
SPARKS, NEVADA, 89431  
(775) 359-4712 FAX (775) 359-7424  
E-MAIL: HAWS@HAWSCO.COM  
WEBSITE: WWW.HAWSCO.COM

ECN NO. REVISED PER BY:	MODEL(S)
DRAWN: E. VASQUEZ	1109.14
APPROVED: FV	
DATE: 11/12/21	SCALE: NA
DATE: 06/98	DRAWING TYPE:
CHKD: BJM	INSTALLATION:
DATE: 11/12/21	SIZE: A
	SHEET: 1 OF 1
	REVISION: 17

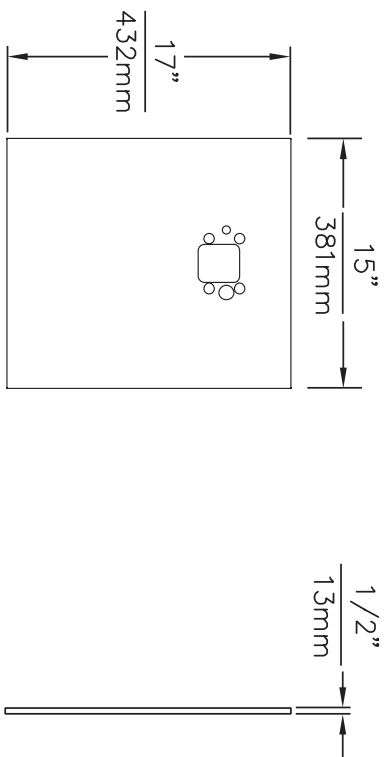

**MODEL BP15 / BP15HPS**

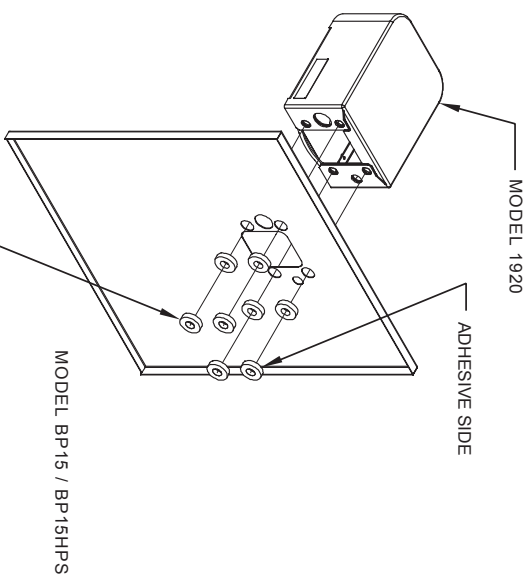

8 SPACERS (2 PER MOUNTING BOLT IF THE MOUNTING PLATE IS INSTALLED BEHIND THE FINISHED WALL. USE 1 SPACER PER BOLT FOR RETROFITS WHERE THE MOUNTING PLATE IS INSTALLED IN FRONT OF THE FINISHED WALL)

**INSTALLATION OVER SINGLE FOUNTAIN**  
SHOWN FROM REAR

- NOTES:  
1. WHEN INSTALLING THIS UNIT, LOCAL, STATE OR FEDERAL CODES SHOULD BE ADHERED TO.

©2017 Haws Corporation - All Rights Reserved. HAWS® and other trademarks used in these materials are the exclusive property of Haws Corporation.

		1455 KLEPPELANE SPARKS, NEVADA 89431 (775) 359-4712 FAX (775) 359-7424 E-MAIL: HAWS@HAWSCO.COM WEBSITE: WWW.HAWSCO.COM	
ECNO	REVISED PER:	MODEL(S)	PART NUMBER
DRAWN:	GC:	MODEL 1109 AND 1109.14 WITH	1109-20
GC	DATE: 09/31/17	MODEL 1920 BOTTLE FILLER	REVISION DA.1
APPROVED:	DATE:	SCALE: 1:1	DRAWING TYPE: INSTALLATION
		SHEET: A	SHEET 2 OF 2

6700 MOUNTING PLATE  
(BEHIND FINISH WALL)  
- OR -  
6700R RETROFIT PLATE  
(ON TOP OF FINISH WALL)

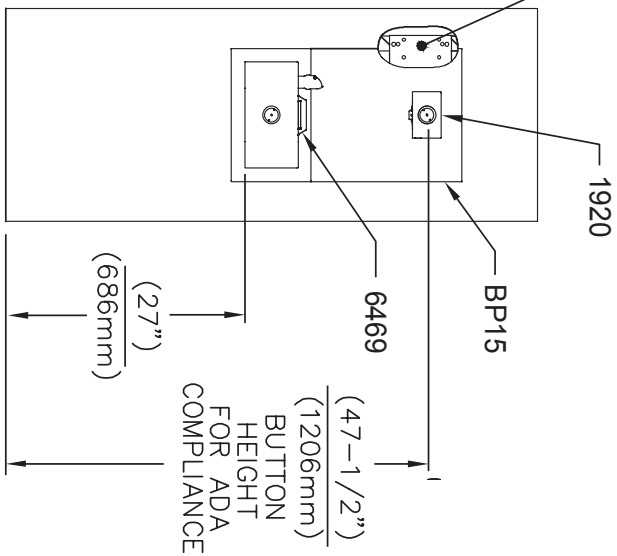

**INSTALLATION ABOVE HAWS 1109, 1109.14**



- \* IF YOUR FOUNTAIN IS THIS STYLE USE THESE DIMENSIONS
1. SEE SEPARATE INSTALLATION DRAWINGS FOR MOUNTING PLATES, BACKPANELS & DRIP TRAY
  2. WHEN INSTALLING THIS UNIT, LOCAL, STATE OR FEDERAL CODES SHOULD BE ADHERED TO FOR INSTALLATION LOCATIONS, WASTE & SUPPLY REQUIREMENTS OTHER THAN SHOWN.

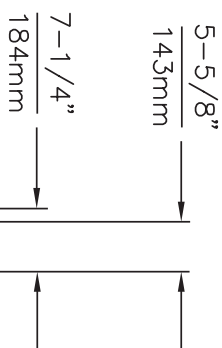

3/8" PUSH IN TEE  
(CONNECT TO  
FOUNTAIN SUPPLY)



**Haws**

1455 KLEPPE LANE  
SPARKS, NEVADA 89431  
(775) 359-4712 FAX (775) 359-7424  
E-MAIL: HAWS@HAWS.CO.COM  
WEBSITE: WWW.HAWS.CO.COM

ECNNO	REVISED PER BY	MODEL(S)	
DRAWN	ECN	DATE	CHKD
GC	DATE	DATE	
APPROVED	DATE	SCALE	VA
		DRAWING TYPE	
		INSTALLATION	
		SIZE	A
		SHEET	1 OF 2
		PART NUMBER	1109-20
		REVISION	0A.1
		MODEL	MODEL 1109 AND 1109.14 WITH MODEL 1920 BOTTLE FILLER

THIS DOCUMENT IS TRUE AND CORRECT AT TIME OF PUBLICATION. CONTINUED PRODUCT IMPROVEMENTS MAKE SPECIFICATIONS AND MEASUREMENTS SUBJECT TO CHANGE WITHOUT NOTICE.

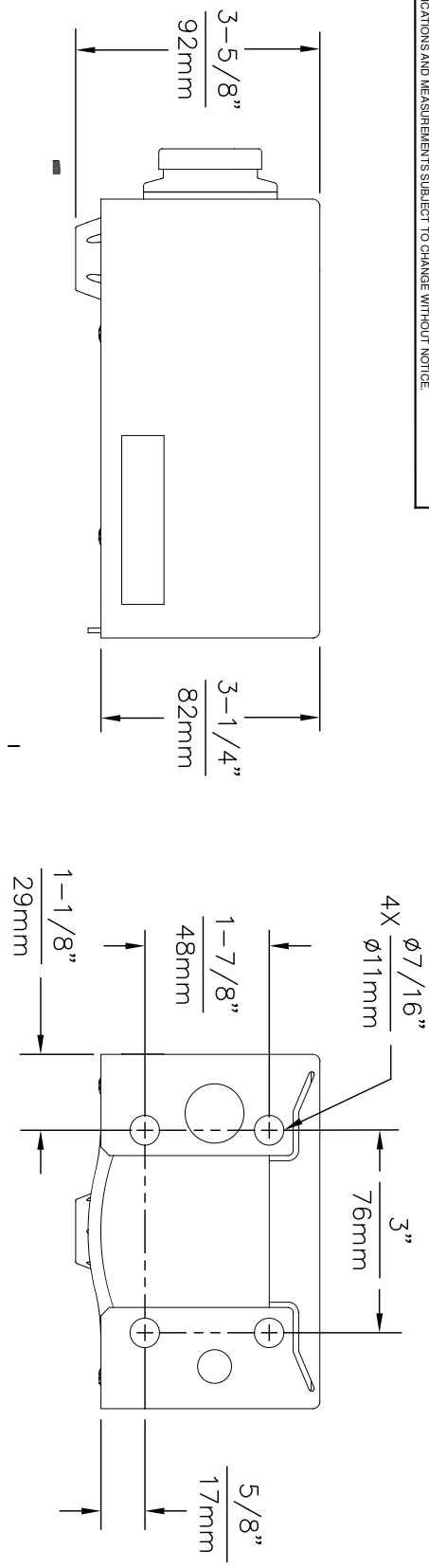

1920 MOUNTING HOLE LOCATIONS

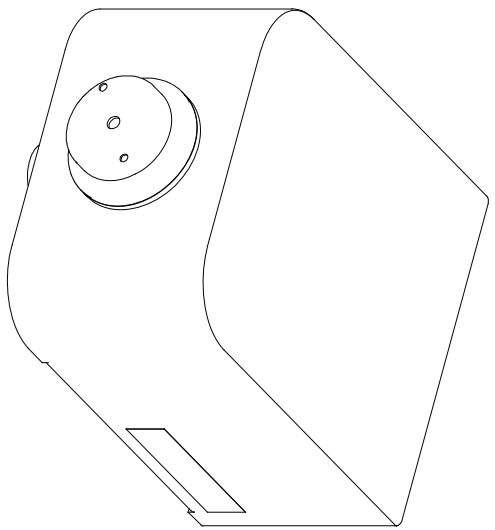
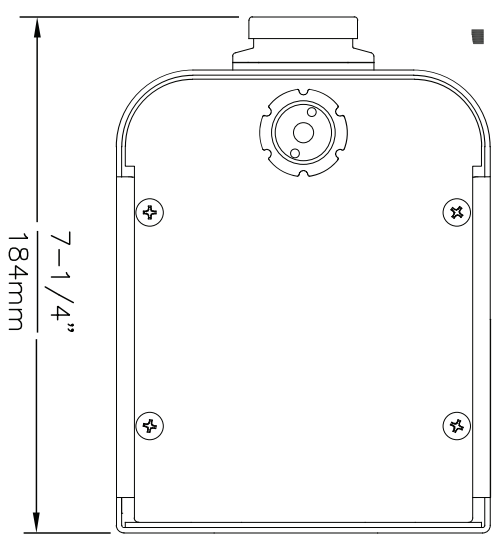

NOTES:

1. SEE SEPERATE INSTALLATION DRAWINGS FOR MOUNTING PLATES AND BACKPANELS
2. WHEN INSTALLING THIS UNIT, LOCAL, STATE OR FEDERAL CODES SHOULD BE ADHERED TO FOR INSTALLATION LOCATIONS, WASTE & SUPPLY REQUIREMENTS OTHER THAN SHOWN.

				1455 KLEPPER LANE SPARKS, NEVADA 89431 (775) 389-4712 FAX (775) 389-7424 E-MAIL: HAWS@HAWS.CO.COM WEBSITE: WWW.HAWS.CO.COM	
ENVD REBENG PER BR 5081 ECK 5172 DS 052516 FV APPROVED: FV	DATE: 022217 DATE: 052516 DATE: 022217	MODEL(S) MODEL 1920/1920HPS/1920W	MODEL(S) MODEL 1920/1920HPS/1920W	SCALE: N/A DRAWING TYPE:	INSTALLATION:
PART NUMBER 051000490.D REVISION: 2					

©2017 Haws Corporation - All Rights Reserved. HAWS® and other trademarks used in these materials are the exclusive property of Haws Corporation.

