

NOTES:

1. INSTALLER MUST UNDERSTAND AND ADHERE TO LOCAL, STATE, AND FEDERAL CODES AND REGULATIONS, INCLUDING THE AMERICANS WITH DISABILITIES ACT (ADA).
2. WALL BRACKET MAY BE INSTALLED IN CONCRETE/MASONRY, WITH APPROPRIATE IN-WALL BLOCKING, OR WITH HAWS IN-WALL MOUNTING PLATE MODEL 6700 (SOLD SEPARATELY - NOT SUPPLIED).
3. INSTALL THE WALL BRACKET WITH A LEVEL AND APPROPRIATE 3/8" DIAMETER HARDWARE USING ONE OF THE METHODS IN NOTE 2. IF NOT INSTALLED IN AN ALCOVE, THE ADA MAY REQUIRE THAT THE BOTTOM OF THE BRACKET BE A MAXIMUM OF 25-1/4" ABOVE THE FLOOR (27" BOTTOM OF FIXTURE) LEVEL FOR CANE DETECTION (SEE NOTE 1).
4. INSTALL SHORT ARM WITH QTY. 4 EACH 3/8" X 3/4" LONG BOLTS (SUPPLIED).
5. PLACE TRIM RING UNDER 3690 BOTTLE FILLER AND PLACE BOTTLE FILLER ON SHORT ARM.
6. INSTALL 4 EACH 3/8" X 1-1/4" LONG BOLTS (SUPPLIED) THROUGH HOLES IN BOTTOM OF BOTTLE FILLER AND MATCHING HOLES IN SHORT ARM.
7. CAREFULLY CENTER TRIM RING AND BOTTLE FILLER BEFORE INSTALLING FOUR 3/8" SERRATED FLANGE NUTS (SUPPLIED) ONTO BOLTS AND TIGHTENING.
8. INSTALL DRAIN AND SUPPLY PLUMBING THROUGH WALL AS REQUIRED. SUPPLY IS BY 3/8" OUTSIDE DIAMETER TUBING AND COMPRESSION FITTINGS.
9. SECURE BOTTOM SHORT ARM COVER TO BOTTOM OF SHORT ARM WITH 3 TAMPER RESISTANT BUTTON HEAD SCREWS (SUPPLIED).

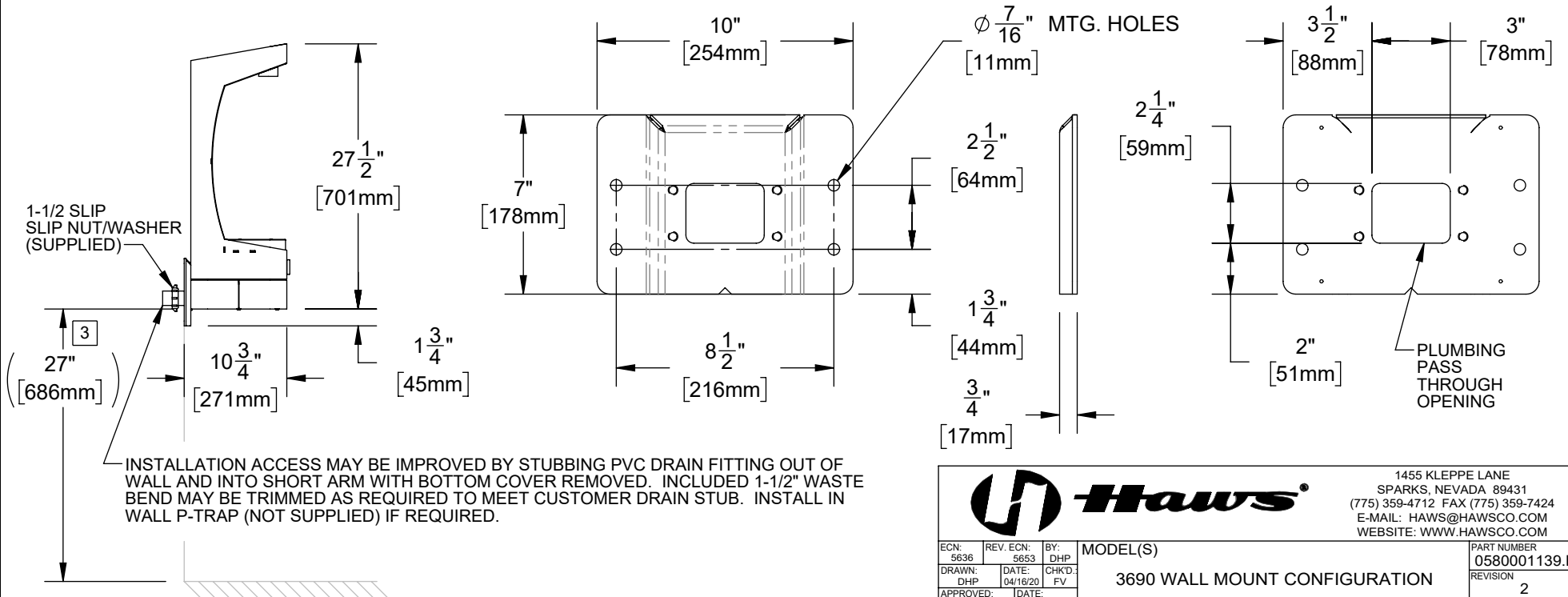
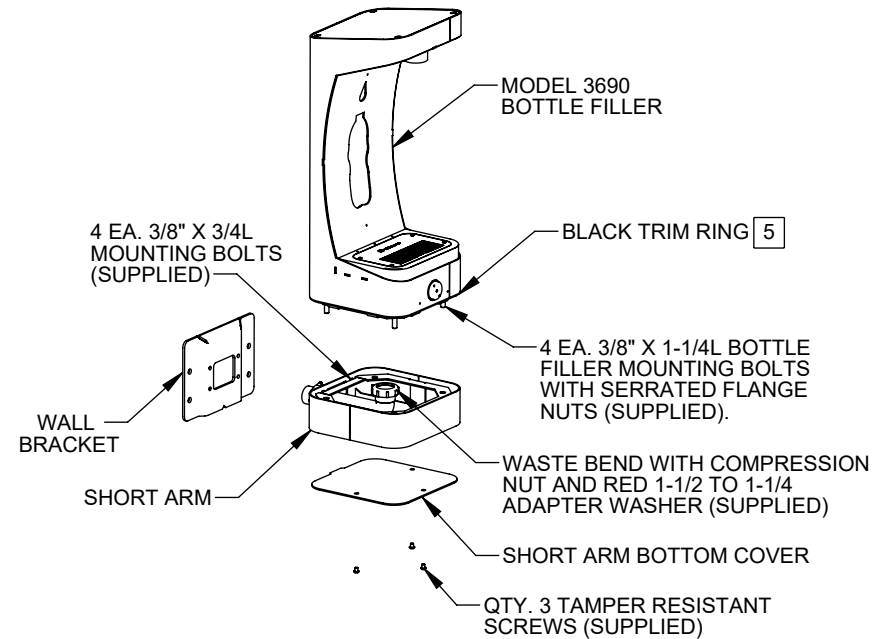

1455 KLEPPE LANE  
SPARKS, NEVADA 89431  
(775) 359-4712 FAX (775) 359-7424  
E-MAIL: HAWS@HAWSO.COM  
WEBSITE: WWW.HAWSO.COM

|              |                |  |                            |                                    |              |
|--------------|----------------|--|----------------------------|------------------------------------|--------------|
|              |                | <b>MODEL(S)</b><br>3690 WALL MOUNT CONFIGURATION |                            | <b>PART NUMBER</b><br>0580001139.D |              |
| ECN: 5636    | REV. ECN: 5653 | BY: DHP  |                            |                                    |              |
| DRAWN: DHP   | DATE: 04/16/20 | CHKD: FV   |                            |                                    |              |
| APPROVED: DP | DATE: 03/02/21 | SCALE: 1:8                                       | DRAWING TYPE: INSTALLATION | SIZE: A                            | SHEET 1 OF 1 |