

FEATURES & BENEFITS

DRINKING FOUNTAIN VALVE

ADA compliant push button activated valve offers the only all stainless-steel valve body that is machined out of solid bar stock. It is fully serviceable through the front of the push button assembly offering access to the water control cartridge and integral water supply strainer, and with front access to the water stream height adjustment for easy maintenance without having to remove the valve. Operating pressure range of 30 to 90 psi (2.1 to 6.2 bar).

BOTTLE FILLER SPOUT

Fast fill 1 gpm (3.78 L) laminar water flow minimizes splashing, with renewable aerator nozzle insert for easy maintenance.

OPEN DESIGN FILLING

The open design of this bottle-filling station offers a 17" high bottle area, and open sides make it accessible to more users.

ADA COMPLIANCE

Haws wall-mounted sport bottle-filling station is ADA accessible for the wheelchair user and for the standing person, when mounted accordingly.

CONSTRUCTION

Heavy-duty stainless steel construction with a matte-silver powder-coated finish.

DRAIN STRAINER PLATE

Drain cover plate is made of 304 stainless steel with a satin finish, and is furnished with vandal resistant pinned allen head screws and mating allen wrench. This cover plate can also be customized with an optional laser-cut engraved school or company logo.

DRAIN CLEAN-OUT

Top-down access to the drain allows the fountain portion to be cleaned without taking the unit apart, good for outdoor settings with drain-clogging sediment such as leaves, garbage, and other debris.

OPTIONS

- Nozzle for Bottle Filler: Model VRKNOZ1 is a package of ten replacement nozzles.
- Valve Cartridge: Model VRK5874HF 1 GPM water control cartridge with water supply strainer.
- Optional custom colors available.

For more information, visit www.hawsco.com or call (888) 640-4297.



SPECIFICATIONS

Wall-mounted ADA compliant sport bottle-filling station for all users when mounted with water nozzle outlet no higher than 48" inches. Heavy-duty stainless steel construction with powder-coated matte silver color finish. Push button activated valve with machined stainless-steel body, and with chrome-plated brass vandal-resistant push button assembly which allows for front access to the water control cartridge, stream adjustment, and water supply strainer replacement. Quick-fill 1.0 gpm laminar water flow with renewable nozzle inserts, and a level base 304 stainless steel drain cover plate.

APPLICATIONS

The 3690 WM offers a solution for the changing needs of outdoor settings as well as outdoor wheelchair access, appealing to all users through accessibility and safety. This is ideal in areas such as parks, schools, and other outdoor areas where hydration facilities are needed. Model meets all current Federal Regulations for the disabled including those in the Americans with Disabilities Act. Haws manufactures drinking fountains, faucets and electric water coolers to be lead-free by all known definitions including NSF/ANSI/CAN 61- Section 9, NSF/ANSI/CAN 372, California Proposition 65, and the Federal Safe Drinking Water Act. Product is compliant to California Health and Safety Code 116875 (AB 1953-2006), and NSF/ANSI/CAN 61: Q ≤ 1

NOTES:

1. INSTALLER MUST UNDERSTAND AND ADHERE TO LOCAL, STATE, AND FEDERAL CODES AND REGULATIONS, INCLUDING THE AMERICANS WITH DISABILITIES ACT (ADA).
2. WALL BRACKET MAY BE INSTALLED IN CONCRETE/MASONRY, WITH APPROPRIATE IN-WALL BLOCKING, OR WITH HAWS IN-WALL MOUNTING PLATE MODEL 6700 (SOLD SEPARATELY - NOT SUPPLIED).
3. INSTALL THE WALL BRACKET WITH A LEVEL AND APPROPRIATE 3/8" DIAMETER HARDWARE USING ONE OF THE METHODS IN NOTE 2. IF NOT INSTALLED IN AN ALCOVE, THE ADA MAY REQUIRE THAT THE BOTTOM OF THE BRACKET BE A MAXIMUM OF 25-1/4" ABOVE THE FLOOR (27" BOTTOM OF FIXTURE) LEVEL FOR CANE DETECTION (SEE NOTE 1).
4. INSTALL SHORT ARM WITH QTY. 4 EACH 3/8" X 3/4" LONG BOLTS (SUPPLIED).
5. PLACE TRIM RING UNDER 3690 BOTTLE FILLER AND PLACE BOTTLE FILLER ON SHORT ARM.
6. INSTALL 4 EACH 3/8" X 1-1/4" LONG BOLTS (SUPPLIED) THROUGH HOLES IN BOTTOM OF BOTTLE FILLER AND MATCHING HOLES IN SHORT ARM.
7. CAREFULLY CENTER TRIM RING AND BOTTLE FILLER BEFORE INSTALLING FOUR 3/8" SERRATED FLANGE NUTS (SUPPLIED) ONTO BOLTS AND TIGHTENING.
8. INSTALL DRAIN AND SUPPLY PLUMBING THROUGH WALL AS REQUIRED. SUPPLY IS BY 3/8" OUTSIDE DIAMETER TUBING AND COMPRESSION FITTINGS.
9. SECURE BOTTOM SHORT ARM COVER TO BOTTOM OF SHORT ARM WITH 3 TAMPER RESISTANT BUTTON HEAD SCREWS (SUPPLIED).

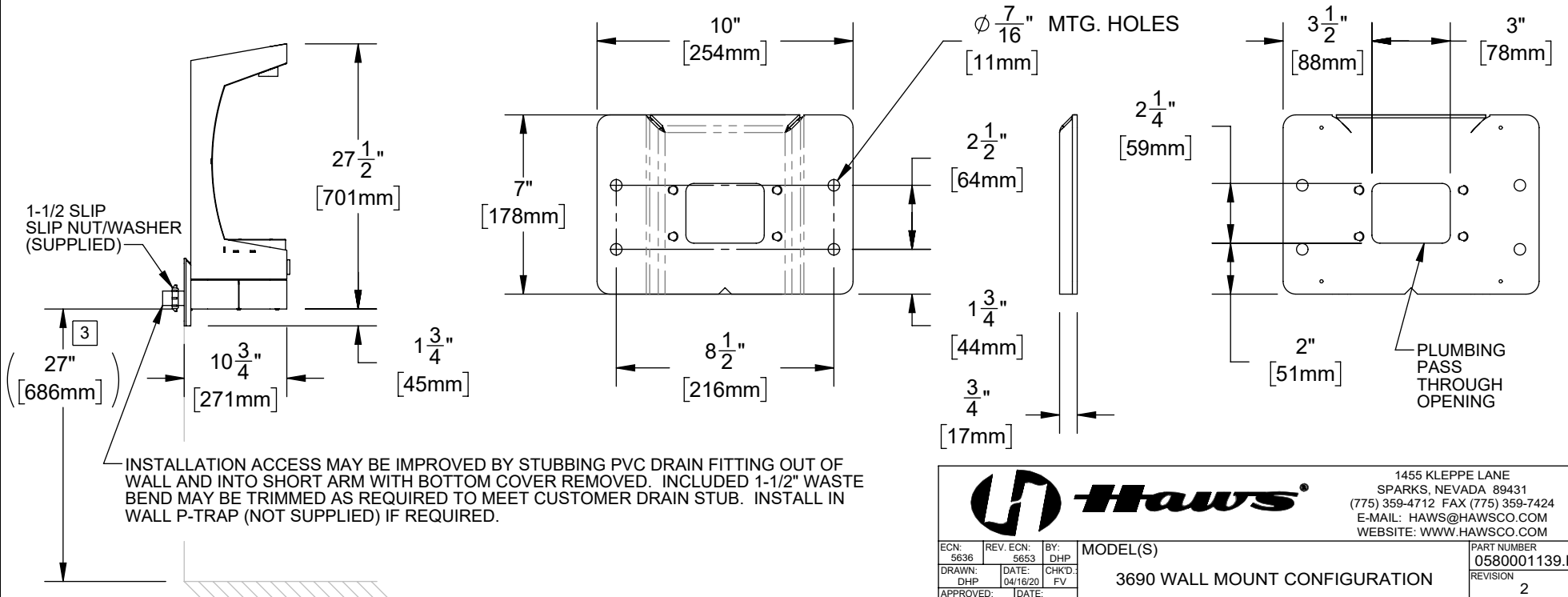
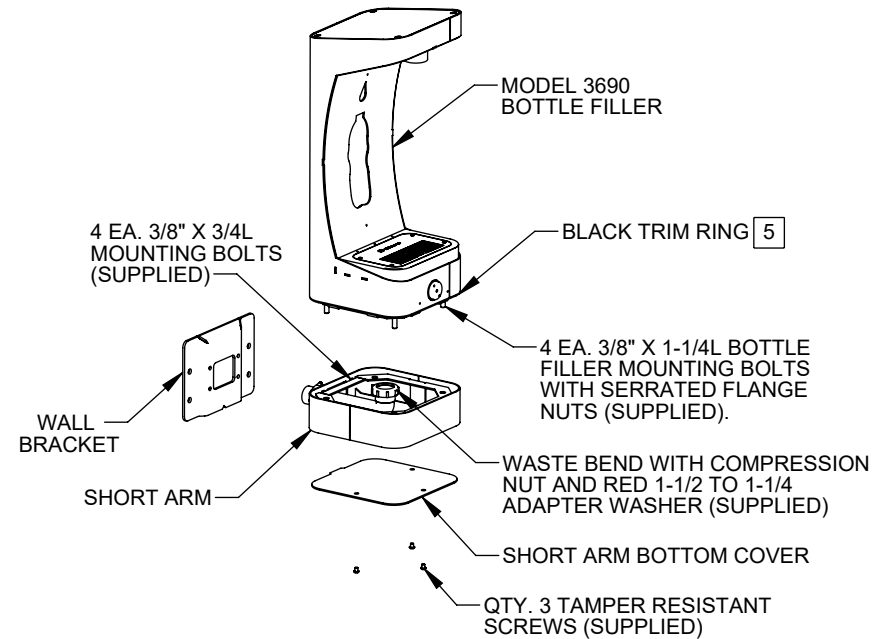

Haws

1455 KLEPPE LANE
SPARKS, NEVADA 89431
(775) 359-4712 FAX (775) 359-7424
E-MAIL: HAWS@HAWSO.COM
WEBSITE: WWW.HAWSO.COM

ECN: 5636	REV. ECN: 5653	BY: DHP	MODEL(S)	PART NUMBER
DRAWN: DHP	DATE: 04/16/20	CHKD: FV	3690 WALL MOUNT CONFIGURATION	0580001139.D
APPROVED: DP	DATE: 03/02/21			REVISION
			SCALE: 1:8	2
			DRAWING TYPE: INSTALLATION	SHEET 1 OF 1