



model 3610FR

ADA Vandal-Resistant Outdoor Freeze-Resistant Stainless-Steel Bottle Filler

FEATURES & BENEFITS

ADA COMPLIANCE

ADA-compliant bottle filling station for wheel chair use.

BOTTLE FILLER

The ADA-compliant open design bottle filling station offers a 17" high bottle area, and open sides making this push button operated bottle filling station more accessible to users.

FREEZE-RESISTANT VALVE

Fully-engineered system with the pneumatic-operated, freeze-resistant valve installed below frost line to drain water to non-freezing depth allowing fountain to function year round. Assembly can be lifted to surface and lowered back into casing for easy maintenance without disturbing the fountain.

CONSTRUCTION

Heavy-duty stainless steel with silver powder-coated finish. Modular construction allows for easy replacement or rearrangement of drinking fountain bowls and bottle filler modules.

VANDAL-RESISTANT

The push button, drain strainer and access plates are locked in place, discouraging unwanted vandal tampering.

OPTIONS

Installation Aid: Model MTG.3600, mounting plate for 3600 series pedestals.

Standard-use Version: Model 3610, ADA stainless steel bottle filler.

For more information, visit www.hawsc.com or call (888) 640-4297.



SPECIFICATIONS

Model 3610FR ADA vandal-resistant outdoor, freeze-resistant pedestal mounted bottle filler shall include a heavy-duty stainless steel pedestal with matte silver powder-coating, fully engineered pneumatic valve assembly, large-opening bottle filler with quick-fill 1 gpm flow rate, 100% lead-free waterways, vandal-resistant access plates, integral mounting feet, and 1-1/2" slip waste.

REQUIRES MODEL 6518FR PRICED SEPARATELY. REQUIRES MODEL 6518FR PRICED SEPARATELY (Consult with the local authority having jurisdiction before installation in order to determine if any additional regulations or requirements may apply)

APPLICATIONS

The 3610FR offers a solution for the changing needs of outdoor settings as well as outdoor wheelchair access, appealing to all users through accessibility and safety. This bottle filler is ideal in areas such as parks, schools, and other outdoor areas where hydration facilities are needed. Model meets all current Federal Regulations for the disabled including those in the Americans with Disabilities Act. Haws manufactures drinking fountains, faucets and electric water coolers to be lead-free by all known definitions including NSF/ANSI/CAN 61-Section 9, NSF/ANSI/ CAN 372, California Proposition 65, and the Federal Safe Drinking Water Act. Product is compliant to California Health and Safety Code 116875 (AB 1953-2006), and NSF/ANSI/CAN 61: Q ≤ 1.



- NOTES:
1. WHEN INSTALLING THIS UNIT, LOCAL, STATE, OR FEDERAL CODES SHOULD BE ADHERED TO. INSTALL A TRAP IN THE WASTE LINE AND A SCREWDRIVER STOP IN THE SUPPLY LINE IF REQUIRED.

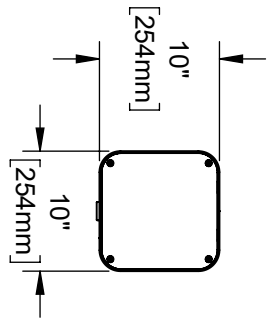

NOTE: PUSH BUTTON SHOWN IS FOR REF. ONLY. ACTUAL PUSH BUTTON IS DIFFERENT STYLE.

ADA COMPLIANT BOTTLE FILLER

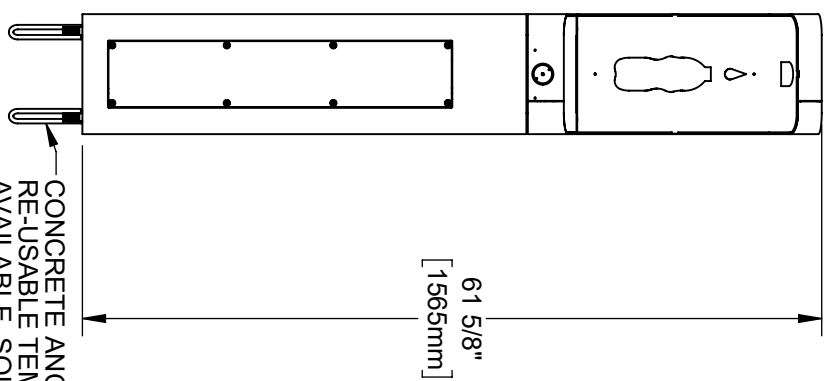

CONCRETE ANCHORS INCLUDED. RE-USABLE TEMPLATE MODEL M.T.G. 3600 AVAILABLE, SOLD SEPARATELY.

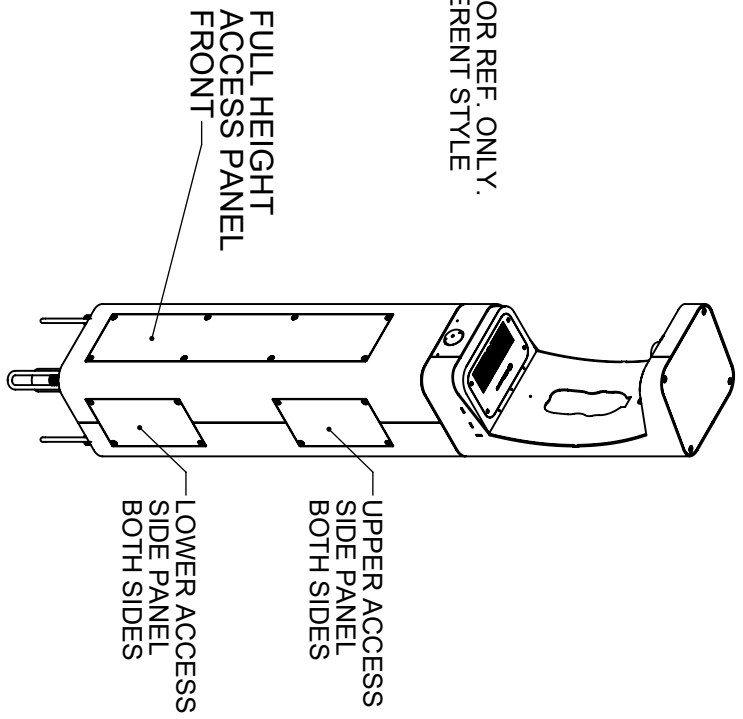

HAWES MODEL 3610FR IS FULLY COMPLIANT WITH THE FEDERAL 2010 AMERICANS WITH DISABILITIES ACT (ADA) ACCESSIBILITY REQUIREMENTS WHEN INSTALLED AS SHOWN HERE AND WHEN INSTALLED WITH PROPER CLEARANCES AND ACCESS. LOCATE THE PEDESTAL BASE WITH AT LEAST 8" OF CLEAR UNOBSTRUCTED HARDSCAPE BEHIND THE PEDESTAL. IT IS THE RESPONSIBILITY OF THE INSTALLER TO ADHERE TO LOCAL, STATE, AND FEDERAL CODES WHEN INSTALLING THIS UNIT. DISTANCE TO SURROUNDING OBJECTS, APPROACH SURFACES, ETC. SHOULD BE CONSIDERED.

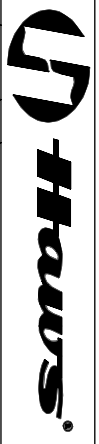

1455 KLEPPE LANE
SPARKS, NEVADA 89431
(775) 359-4712 FAX (775) 389-7424
E-MAIL: HAWS@HAWSCCO.COM
WEBSITE: WWW.HAWSCCO.COM

ENCL. 5652	REV. E/CN. 5/7/9	BY. F.V.	MODEL(S) 3610FR
DRAWING NO. 5652	DATE: 07/21/01	CHKD. B.M.	
APPROVED: F.V.	DATE: 09/16/21	SCALE: 1/2"	DRAWING TYPE: INSTALLATION
		SIZE: A	SHEET 1 OF 7
			REVISION: 2
			PART NUMBER: 0580001170.D

INSTALLATION INSTRUCTIONS

MODEL MTG-3600
 (OPTIONAL)
 TEMPLATE FOR
 SPACING ANCHORS
 DURING CONCRETE
 POUR

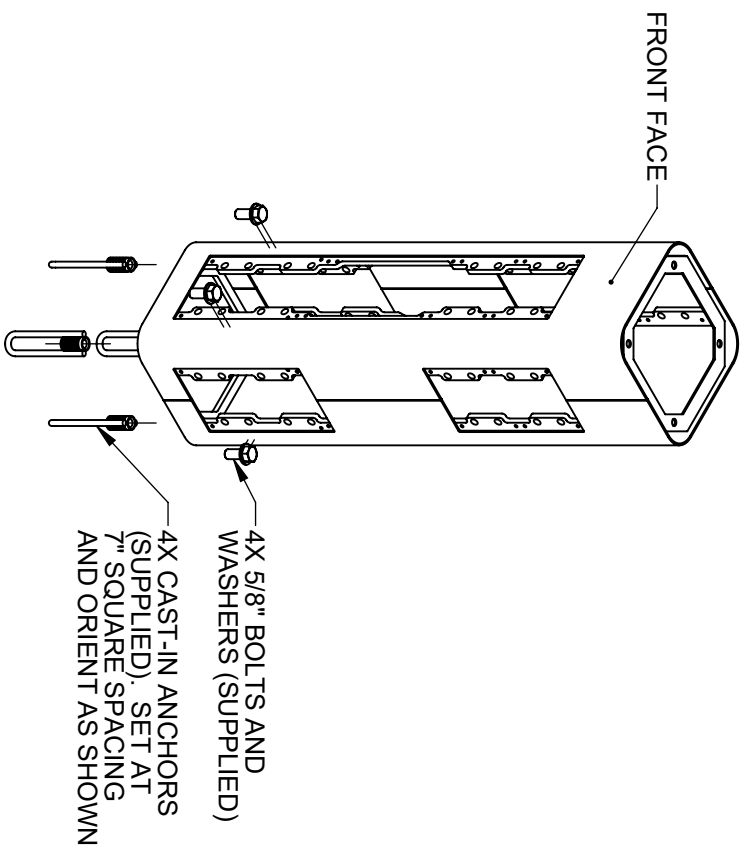
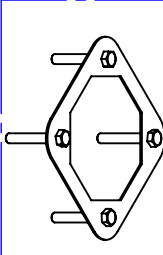

STEP 1
 MOUNT PEDESTAL TO CONCRETE SLAB IN DESIRED ORIENTATION. SLAB TO BE 30" MINIMUM SQUARE AND 6" MINIMUM THICK (BY OTHERS). PLUMBING CAST IN CONCRETE MUST FIT IN 7" DIAMETER AREA CENTERED UNDER PEDESTAL LOCATION. FOR 3610FR MODEL, SEE REQUIRED BURY VALVE (NOT SUPPLIED) INSTALLATION REQUIREMENTS ON SHEET 6.

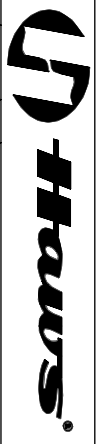
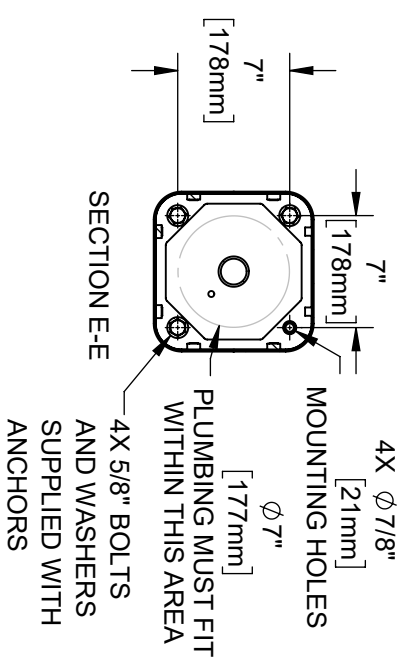
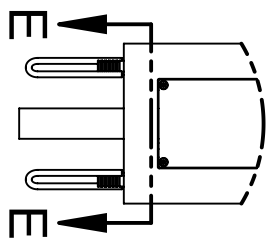

1455 KLEPPE LANE
 SPARKS, NEVADA 89431
 (775) 359-4712 FAX (775) 359-7424
 E-MAIL: HAWS@HAWSCO.COM
 WEBSITE: WWW.HAWSCO.COM

E.N.	REV. E.C.N.	BY:	MODEL(S)	1455 KLEPPE LANE
5652	5719	F.V.	3610FR	SPARKS, NEVADA 89431
DRAWN	DATE	CHK'D		(775) 359-4712 FAX (775) 359-7424
BY	BY	BY		E-MAIL: HAWS@HAWSCO.COM
APPROVED	DATE	DATE		WEBSITE: WWW.HAWSCO.COM
F.V.	09/16/21	SCALE	1/24	DRAWING TYPE
				INSTALLATION
				SIZE
				A
				SHEET
				2 OF 7
				REVISION
				2
				PART NUMBER
				0580001170.D

INSTALLATION INSTRUCTIONS

NOTE: PUSH BUTTON SHOWN IS FOR REF. ONLY. ACTUAL PUSH BUTTON IS DIFFERENT STYLE

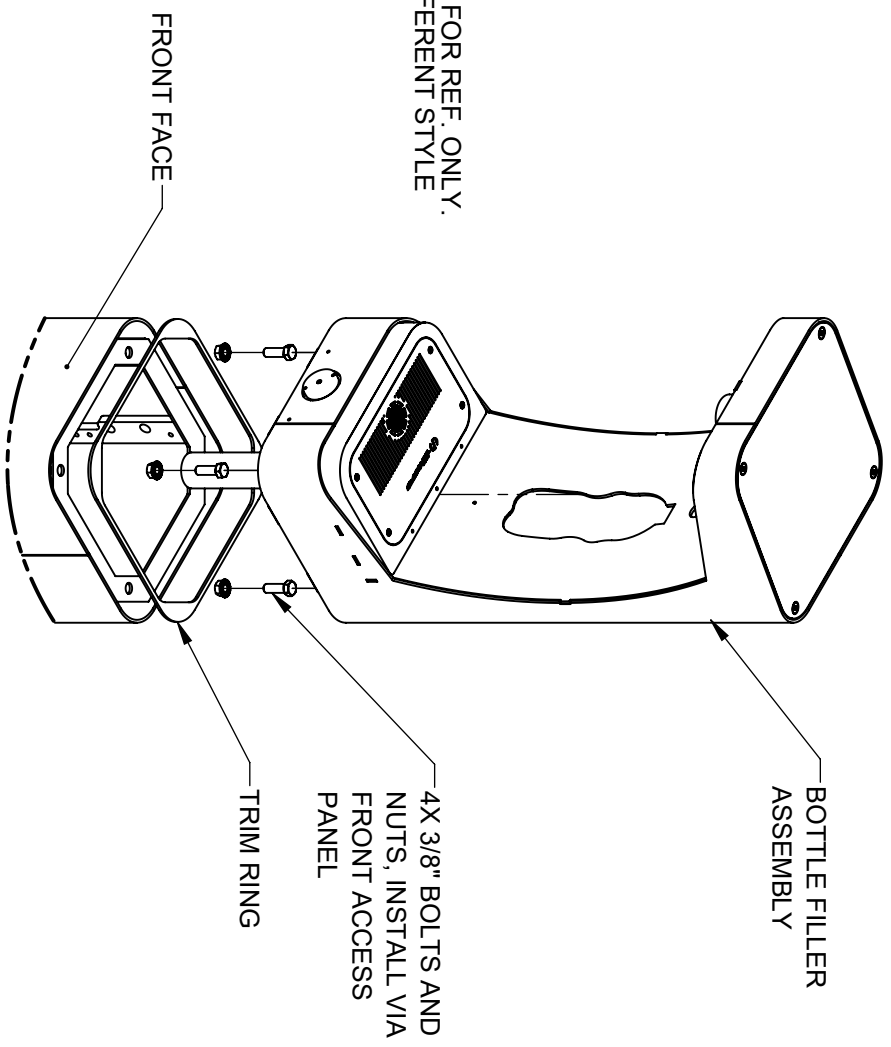

STEP 2

PLACE SQUARE TRIM RING ON BOTTOM OF BOTTLE FILLER AND PLACE BOTTLE FILLER ON TOP OF PEDESTAL, FACING THE FRONT. USE 3/8" BOLTS AND NUTS VIA THE FRONT ACCESS PANEL TO SECURE BOTTLE FILLER TO PEDESTAL. CAREFULLY CENTER TRIM RING AND BOTTLE FILLER AND TORQUE BOLTS/NUTS TO 18 FT-LBS.

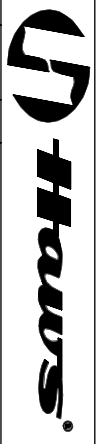

1455 KLEPPE LANE
SPARKS, NEVADA 89431
(775) 359-4712 FAX (775) 359-7424
E-MAIL: HAWS@HAWSCCO.COM
WEBSITE: WWW.HAWSCCO.COM

E.C.N.	REV. E.C.N.	BY:	MODEL(S)	PART NUMBER
5652	5719	F.V.		0580001170.D
DRAWN	DATE	CHK'D		REVISION
BY	BY	BY		2
APPROVED	DATE	SCALE	DRAWING TYPE	
F.V.	09/16/21	1/24	INSTALLATION	
			SIZE: A	SHEET 3 OF 7

INSTALLATION INSTRUCTIONS

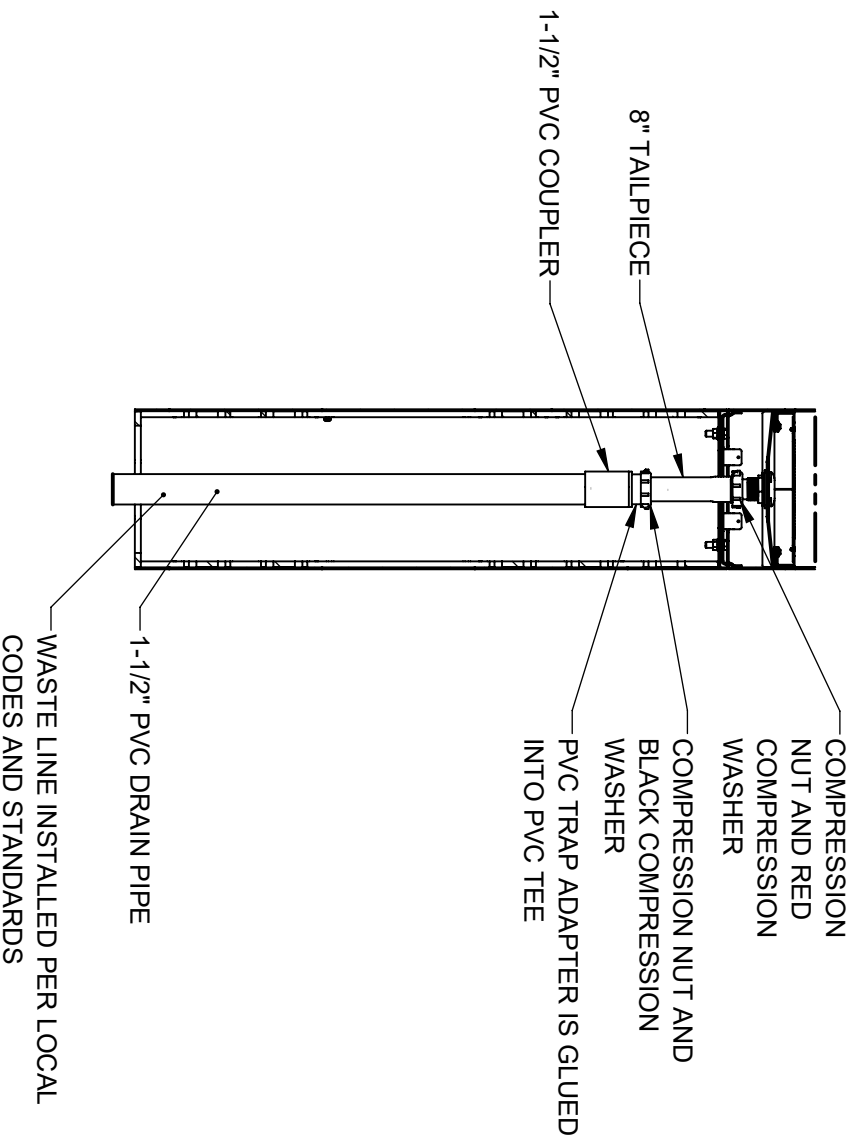

STEP 3

INSTALL SUPPLIED DRAIN COMPONENTS AS SHOWN. RED COMPRESSION WASHER ADAPTS FROM 1-1/4" TO 1-1/2" AT DRAIN TAIL PIECE. BLACK COMPRESSION WASHER IS USED IN TRAP ADAPTER AT COUPLER. USE APPROPRIATE PVC CEMENT TO MAKE SOLVENT CEMENT CONNECTIONS. TRIM TAIL PIECE LENGTH IF REQUIRED. NOTE THAT EXTRA PARTS MAY BE INCLUDED TO FACILITATE OTHER CONFIGURATIONS OF THIS FOUNTAIN.



Haws

1455 KLEPPE LANE
SPARKS, NEVADA 89431
(775) 359-4712 FAX (775) 359-7424
E-MAIL: HAWS@HAWSCCO.COM
WEBSITE: WWW.HAWSCCO.COM

ENCL. 5652	REV. ENCL. BY: F.V.	MODEL(S)	3610FR	PART NUMBER	0580001170.D
DRAWN BY: F.V.	DATE: 5/79	DATE: CHRD. 1/22	DATE: B.M.	REVISION	2
APPROVED: F.V.	DATE: 09/16/21	SCALE: 1/24	DRAWING TYPE: INSTALLATION	SIZE: A	SHEET 4 OF 7

INSTALLATION INSTRUCTIONS

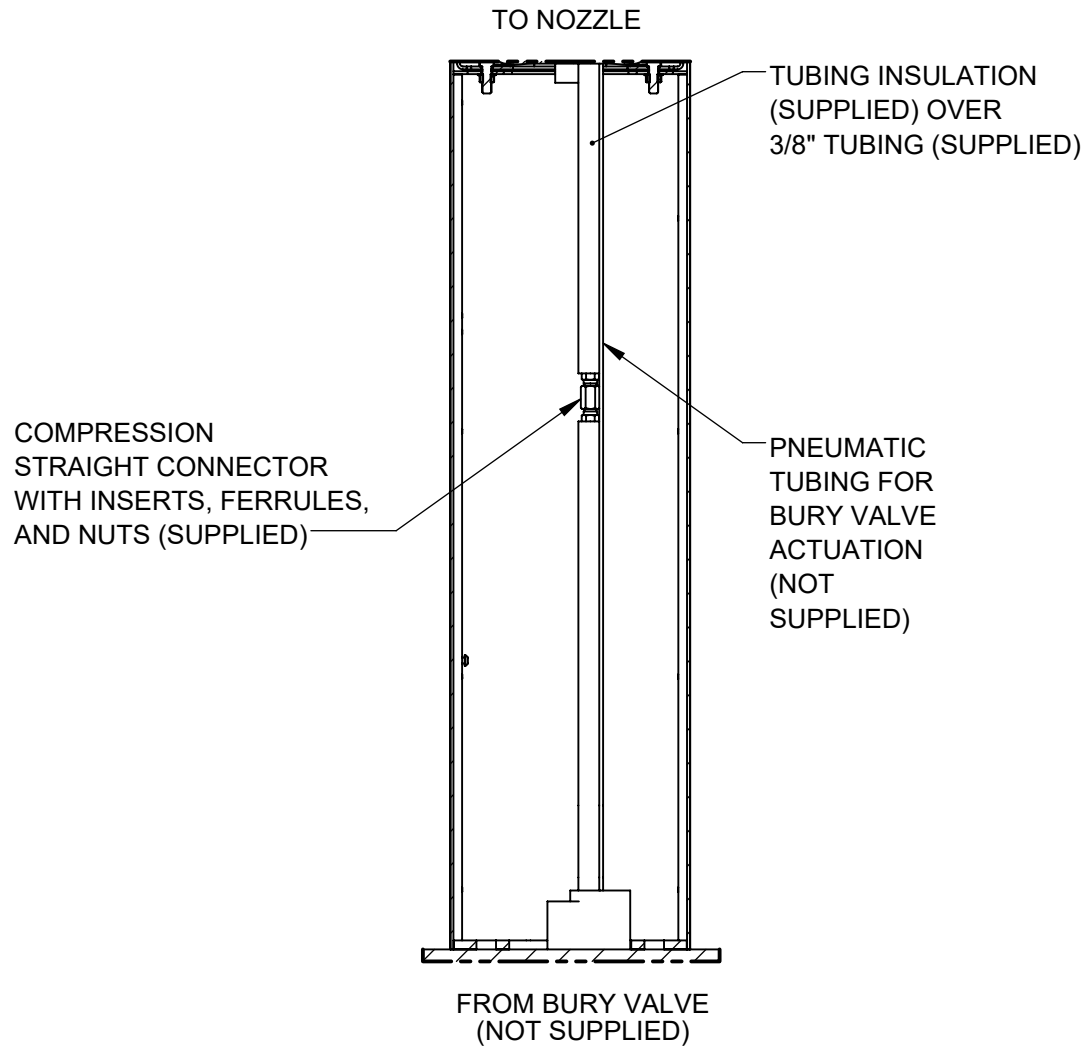

3610FR SUPPLY PLUMBING*

* SEE NEXT SHEET OF THIS DRAWING FOR MORE INFORMATION ON INSTALLING BURY VALVES WITH THIS MODEL.

STEP 4

COMPLETE WATER SUPPLY PLUMBING AS SHOWN. OPEN SUPPLY VALVE AND TEST. REPLACE PEDESTAL ACCESS PLATES BURY VALVE (NOT SUPPLIED) IS REQUIRED FOR 3610FR INSTALLATION. REFER TO BURY VALVE OPERATION AND MAINTENANCE MANUAL FOR ADDITIONAL INFORMATION.

		1455 KLEPPE LANE SPARKS, NEVADA 89431 (775) 359-4712 FAX (775) 359-7424 E-MAIL: HAWS@HAWSO.COM WEBSITE: WWW.HAWSO.COM	
		ECN: 5652 DRAWN: DHP APPROVED: FV	REV. ECN: 5719 DATE: 6/11/20 DATE: 09/16/21
PART NUMBER 0580001170.D			REVISION 2
SCALE: 1:24		DRAWING TYPE: INSTALLATION	SIZE: A SHEET 5 OF 7

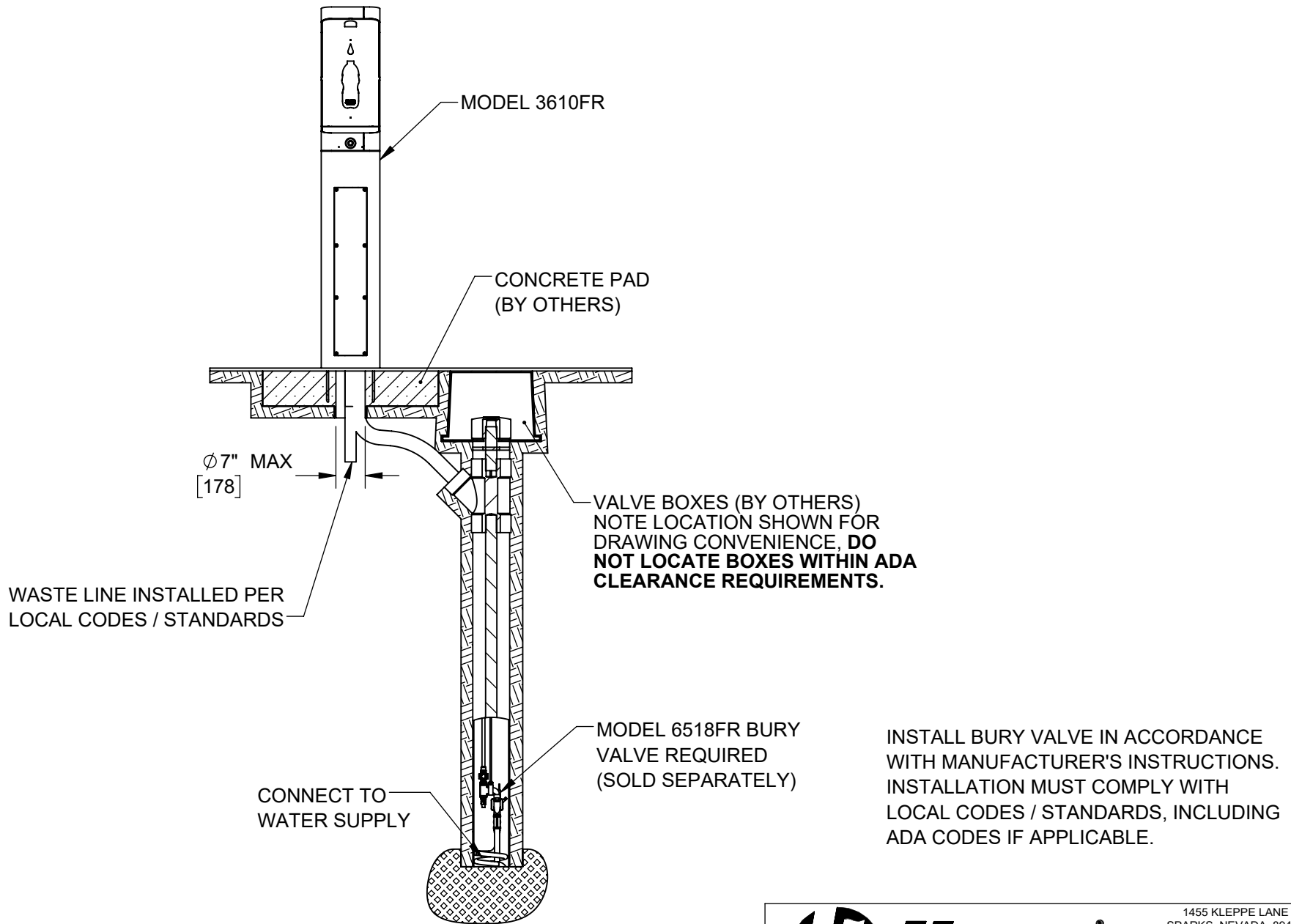

3610FR GENERAL BURY VALVE LAYOUT (FOR REFERENCE ONLY)

INSTALL BURY VALVE IN ACCORDANCE WITH MANUFACTURER'S INSTRUCTIONS. INSTALLATION MUST COMPLY WITH LOCAL CODES / STANDARDS, INCLUDING ADA CODES IF APPLICABLE.

		1455 KLEPPE LANE SPARKS, NEVADA 89431 (775) 359-4712 FAX (775) 359-7424 E-MAIL: HAWS@HAWS.CO.COM WEBSITE: WWW.HAWS.CO.COM	
		ECN: 5652 DRAWN: DHP APPROVED: FV	REV. ECN: 5719 DATE: 6/11/20 DATE: 09/16/21
PART NUMBER 0580001170.D			REVISION 2
SCALE: 1:24		DRAWING TYPE: INSTALLATION	SIZE: A SHEET 6 OF 7

NOTES ON OPTIONAL CONFIGURATIONS

HAWS 3600FR SERIES OUTDOOR FOUNTAINS ARE MODULAR AND CAN BE ASSEMBLED AND CONFIGURED MANY DIFFERENT WAYS. DISPLAYED HERE ARE A FEW EXAMPLES. CONFIGURATIONS OTHER THAN THAT SHOWN IN THE INSTALLATION INSTRUCTIONS FOR THE 3610FR MAY AFFECT COMPLIANCE WITH ADA REGULATIONS. IT IS THE RESPONSIBILITY OF THE INSTALLER TO UNDERSTAND LOCAL, STATE, AND FEDERAL REGULATIONS AS APPLICABLE IF INSTALLING THIS FOUNTAIN IN CONFIGURATIONS OTHER THAN THAT INDICATED ON SHEET 1 (PAGE 6 OF 12).

BOTTLE FILLER AND FOUNTAINS CAN BE INSTALLED TO FACE ANY DIRECTION

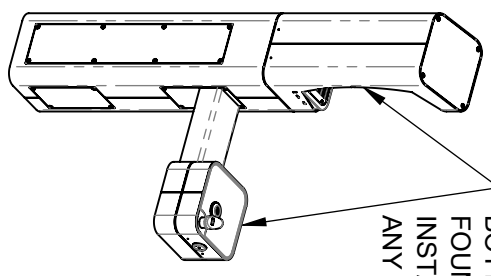

ADA ARM HEIGHT POSITION OPTIONS					
	LEFT SIDE*	RIGHT SIDE*	ARM HEIGHT (LOWER EDGE)	BUBBLER NOZZLE HEIGHT	
STANDING ADA	YES (STD)	NO	31-7/8 [809 mm]	39-3/8 [999 mm]**	
WHEELCHAIR ADA	YES (STD)	YES (STD)	27 [687 mm]	34-5/8 [878 mm]	
CHILD ADA	YES	YES	22-1/4 [566 mm]	29-7/8 [757 mm]	

* RIGHT AND LEFT CAN BE REVERSED IF PEDESTAL IS ROTATED 180°.
 **NOZZLE HEIGHT IS 41-1/2" WHEN FOUNTAIN IS INSTALLED ON TOP OF PEDESTAL.

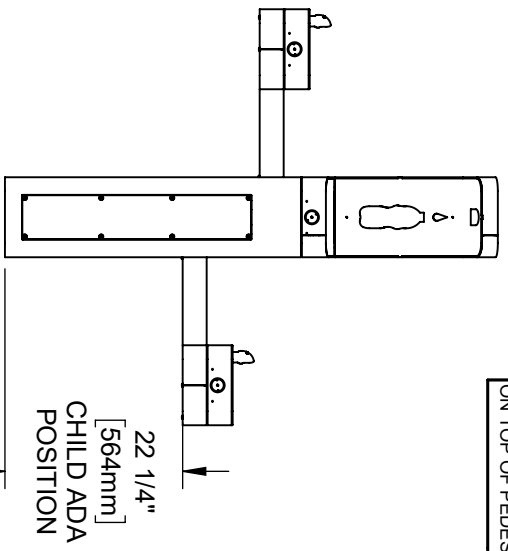

BOTTLE FILLER CAN BE INSTALLED ON ARMS

ADA STANDING HEIGHT FOUNTAIN INSTALLED ON PEDESTAL

27" [687mm] WHEELCHAIR ADA POSITION

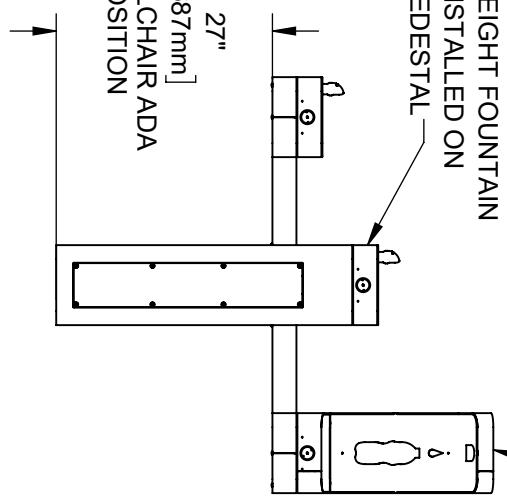

NOTE: PUSH BUTTONS SHOWN ARE FOR REF. ONLY, ACTUAL PUSH BUTTONS ARE DIFFERENT STYLE.

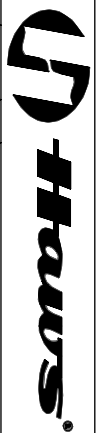

1455 KLEPPE LANE
 SPARKS, NEVADA 89431
 (775) 359-4712 FAX (775) 359-7424
 E-MAIL: HAWS@HAWSCCO.COM
 WEBSITE: WWW.HAWSCCO.COM

ECON: 5652	REV/ECON: F.V.	BY: F.V.	MODEL(S):	3610FR	PART NUMBER: 0580001170.D
DRAWN BY: F.V.	DATE: 5/7/9	CHKD BY: F.V.	SCALE: 1/2" = 1'	DRAWING TYPE: INSTALLATION	SIZE: A
APPROVED BY: F.V.	DATE: 09/16/21	DATE: 09/16/21	SCALE: 1/2" = 1'	DRAWING TYPE: INSTALLATION	SIZE: A
					SHEET 7 OF 7
					2