

4X 1/4"-20 TAMPER RESISTANT SCREWS (SUPPLIED)

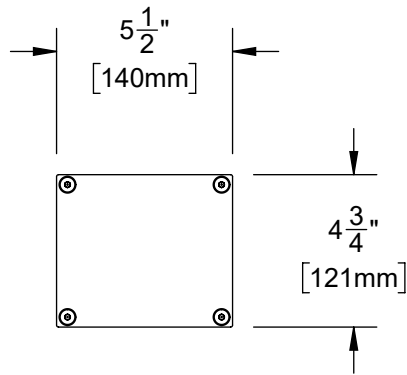

3652
SMALL ACCESS COVER PLATE
DETAIL

MOUNT HERE WITH CHILD HEIGHT FOUNTAIN

MOUNTS HERE WITH ADULT STANDING HEIGHT FOUNTAIN

LEFT SIDE OF MODEL 36XX FOUNTAIN PEDESTAL (SHOWN FOR REFERENCE ONLY - NOT SUPPLIED)

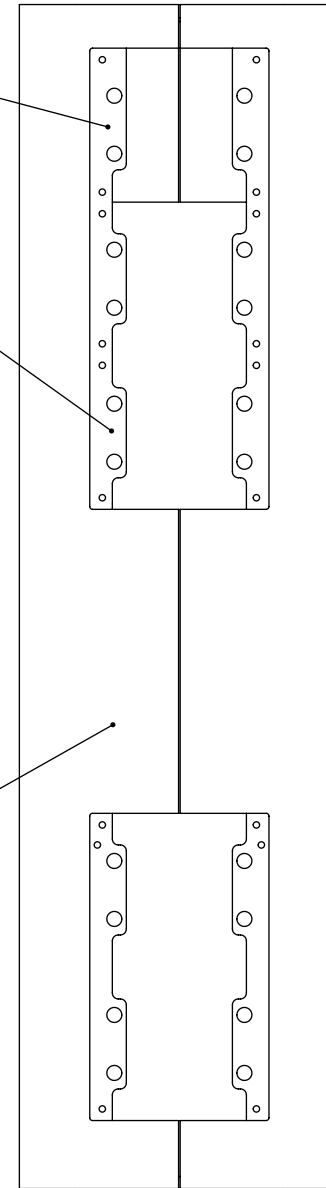

NOTE: MODEL 3652 IS USED TO COVER OPEN SPACE ABOVE OR BELOW UPPER LEFT 36XX ODBF FOUNTAIN ARM (NOT SUPPLIED), AS REQUIRED.



1455 KLEPPE LANE
SPARKS, NEVADA 89431
(775) 359-4712 FAX (775) 359-7424
E-MAIL: HAWS@HAWS.CO.COM
WEBSITE: WWW.HAWS.CO.COM

ECN: 5226	REV. ECN: 5707	BY: FV	MODEL(S) 3652	PART NUMBER 0510000722
DRAWN: MH	DATE: 05/23/17	CHKD: DP		REVISION 4
APPROVED: FV	DATE: 11/04/21	SCALE: 1:6	DRAWING TYPE: INSTALLATION	SIZE: A SHEET 1 OF 1