

## FEATURES & BENEFITS

### ALTERNATIVE

Mounting the proximity switch to the ball valve eliminates plumbing in of the flow switch.

### OPTIONS

For more information, visit [www.hawesco.com](http://www.hawesco.com) or call (888) 640-4297.

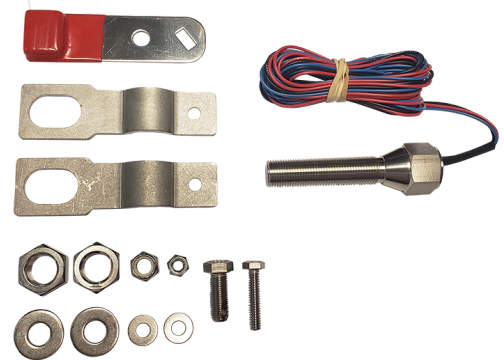

## SPECIFICATIONS

The Haws SP152S is a single pole proximity switch designed to mount to a Haws emergency shower or eyewash. Mounted to the ball valve, the switch sends an electrical signal to an alarm or control board when the emergency fixture is activated. This switch kit include the magnet and mounting hardware.

## APPLICATIONS

Specifically, this proximity switch can be used for most Haws emergency eyewashes or drench showers (not meant for freeze resistant eyewashes and showers).

**NOTES:**

- 1 APPLY SMALL AMOUNT OF THREAD LOCKER (LOCTITE #222MS - SUPPLIED) TO MALE THREADS, WHERE INDICATED.
- 2 APPLY SMALL AMOUNT OF LUBRICANT (DOW CORNING #111 - SUPPLIED) TO PROXIMITY SWITCH (ITEM 1) THREADS, PRIOR TO INSTALLATION (PREVENTS THREAD SEIZING).
3. THESE PROXIMITY SWITCHES ARE CSA CERTIFIED AS ACCESSORIES FOR USE IN HAWS MANUFACTURED ASSEMBLIES.



4. PROXIMITY SWITCH INSTALLATION LOCATIONS:
  - SINGLE PROXIMITY SWITCH MODELS SP152S AND SP152D CAN BE INSTALLED AT EITHER:
    - A) A SHOWER HEAD ONLY (SEE SHEET 2, DETAIL A), OR
    - B) AN EYE/FACE WASH ONLY (SEE SHEET 2, DETAIL B AND SHEET 3)
  - DOUBLE PROXIMITY SWITCH MODELS SP152SC AND SP152DC CAN BE INSTALLED AT:
    - A) BOTH A SHOWER HEAD AND EYE/FACE WASH ON COMBINATION SAFETY SHOWER UNITS (SEE SHEET 2, DETAILS A AND B AND SHEET 3).
5. PROXIMITY SWITCH KIT BRACKETS WILL FIT 1/2" - 1" IPS PIPE SIZES. SEE HAWS MODEL COMPATIBILITY TABLE ON PAGE 3 OF HAWS SP152 SERIES OPERATION AND MAINTENANCE MANUAL, FOR MODELS THAT THESE KITS WILL FIT ON.

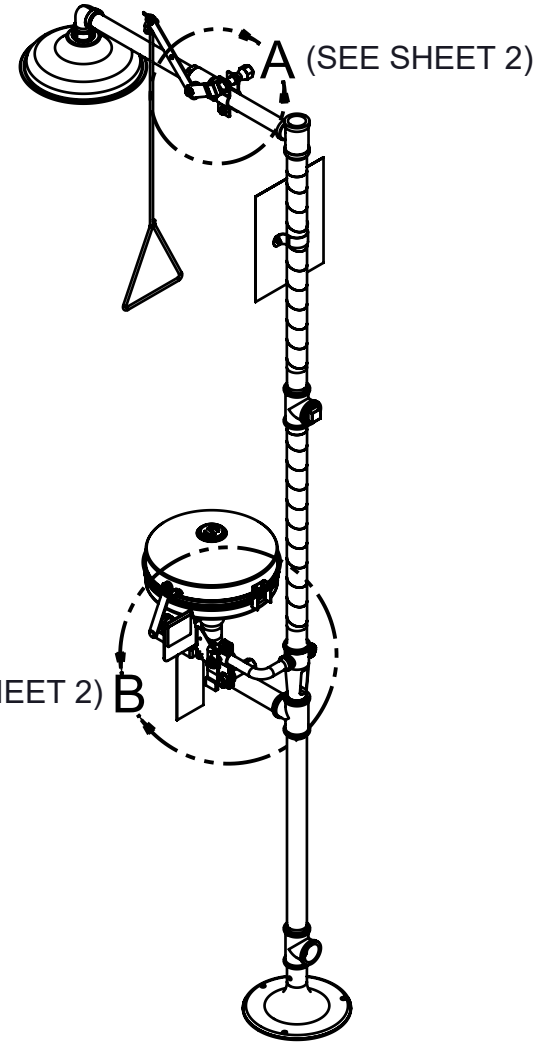

(SEE SHEET 2) B

**HAWS 8300-8309  
SHOWN FOR REFERENCE  
(NOT SUPPLIED)**

PARTS BREAKDOWN					
MODEL NUMBER		SP152S	SP152D	SP152SC	SP152DC
ITEM NO.	DESCRIPTION	QTY.	QTY.	QTY.	QTY.
1	PROXIMITY SWITCH, SPDT	1	--	2	--
	PROXIMTY SWITCH, DPDT	--	1	--	2
2	STRAP, PROXIMITY SWITCH	2	2	4	4
3	WASHER, FLAT, 1/4	2	2	4	4
4	NUT, 1/4-20	1	1	2	2
5	SCREW, 1/4-20 X 1-1/4	1	1	2	2
6	JAM NUT, 5/8-18, PROXIMITY SWITCH	2	2	4	4
7	MAGNET, PROXIMITY SWITCH	1	1	2	2
8	NUT, 3/8-24	1	1	1	1
9	WASHER, FLAT, 3/8	2	2	2	2
10	SCREW, 3/8-24 X 1 W/HOLE	1	1	1	1
N/A	LOCTITE THREAD LOCKER 222MS (0003244389)	1	1	1	1
N/A	DOW CORNING LUBRICANT #111 (0003247000)	1	1	1	1

**SEE SHEET 7 FOR ELECTRICAL WIRING  
OF PROXIMITY SWITCH(ES)**

		1455 KLEPPE LANE SPARKS, NEVADA 89431 (775) 359-4712 FAX (775) 359-7424 E-MAIL: HAWS@HAWS.CO.COM WEBSITE: WWW.HAWS.CO.COM	
ECN: 5551	REV. ECN: 5637	BY: FV	MODEL(S) SP152S/SP152D/SP152SC/SP152DC
DRAWN: LF	DATE: 07/30/20	CHKD: DP	PART NUMBER 0510001049.D
APPROVED: FV	DATE: 01/12/21	SCALE: 1:16	REVISION 2
DRAWING TYPE: INSTALLATION		SIZE: A	SHEET 1 OF 4

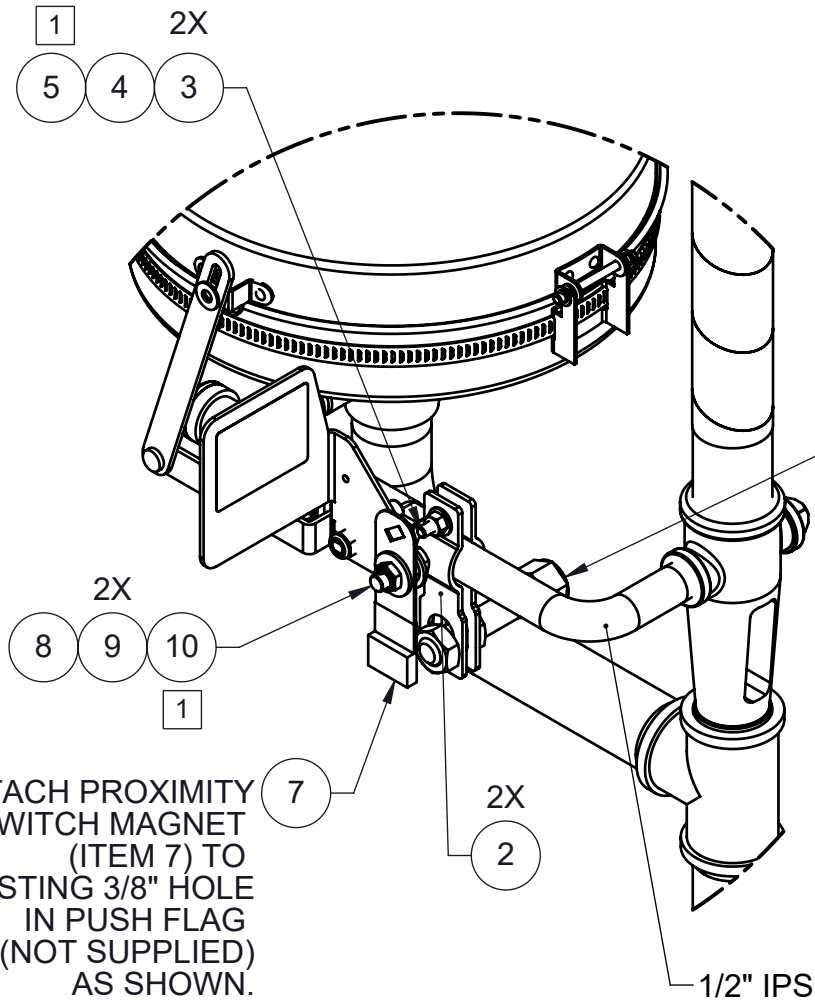

ATTACH PROXIMITY SWITCH MAGNET (ITEM 7) TO EXISTING 3/8" HOLE IN PUSH FLAG (NOT SUPPLIED) AS SHOWN.

**DETAIL B  
(EYE/FACE WASH)**

**SEE SHEET 6 FOR VERTICAL ORIENTATION OF PROXIMITY SWITCH ON EYE/FACE WASH FOR MODELS 7324 OR 8317.**

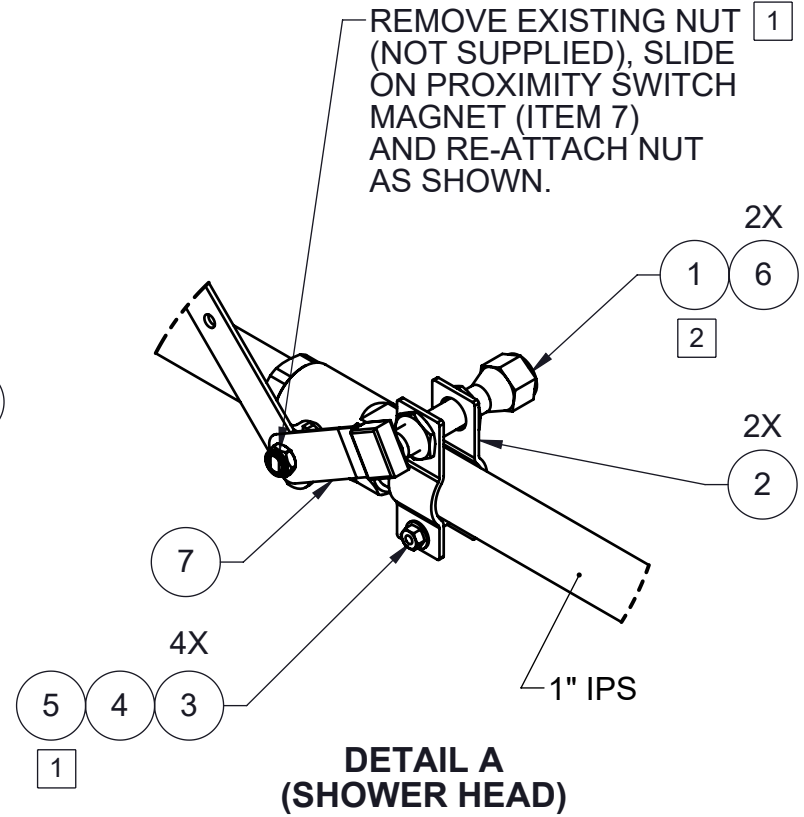

REMOVE EXISTING NUT (NOT SUPPLIED), SLIDE ON PROXIMITY SWITCH MAGNET (ITEM 7) AND RE-ATTACH NUT AS SHOWN.

**DETAIL A  
(SHOWER HEAD)**

**PROXIMITY SWITCH LOCATION DETAILS  
(SWITCHES ARE SHOWN ON A COMBO SHOWER FOR REFERENCE. CERTAIN SHOWER/EYEWASH MODELS MAY REQUIRE THAT THE BRACKETS BE MOUNTED TO CUSTOMER SUPPLY PIPING)**

				1455 KLEPPE LANE SPARKS, NEVADA 89431 (775) 359-4712 FAX (775) 359-7424 E-MAIL: HAWS@HAWSO.COM WEBSITE: WWW.HAWSO.COM	
				ECN: 5551 REV. ECN: 5637 LF: FV APPROVED: FV	BY: FV DATE: 07/30/20 DATE: 01/12/21
SCALE: 1:20		DRAWING TYPE: INSTALLATION		SIZE: A	

TO  
EYE/FACE WASH

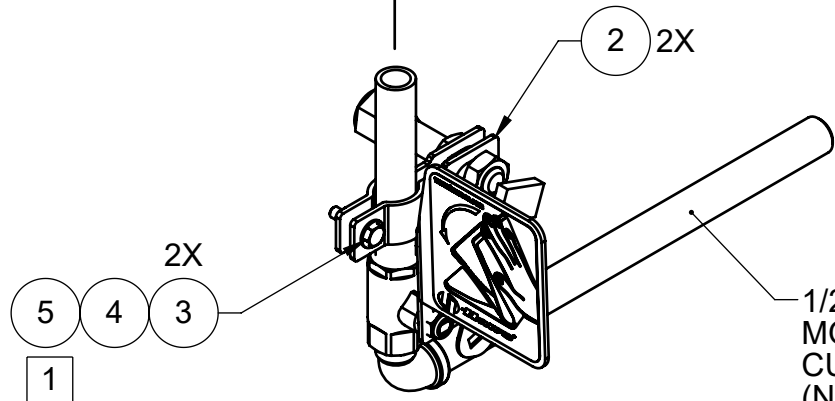

1/2" IPS PIPE ON  
MODEL 8317 OR 1/2" IPS  
CUSTOMER SUPPLY TUBING/PIPE  
(NOT SUPPLIED) ON MODEL 7324.

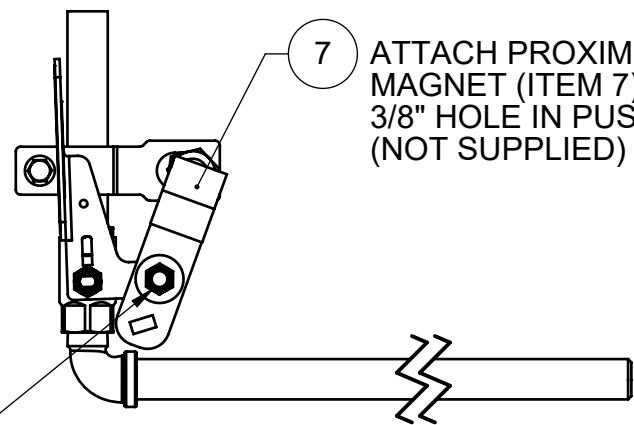
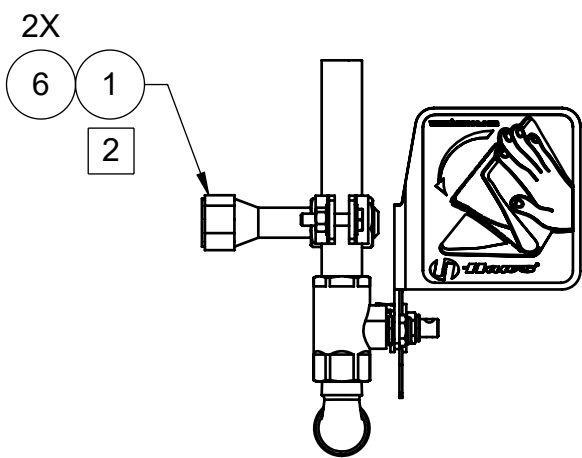

ATTACH PROXIMITY SWITCH  
MAGNET (ITEM 7) TO EXISTING  
3/8" HOLE IN PUSH FLAG  
(NOT SUPPLIED) AS SHOWN.

**VERTICAL ORIENTATION  
OF PROXIMITY SWITCH ON EYE/FACE WASH  
FOR MODELS 7324 OR 8317 SHOWN.  
SEE PREVIOUS SHEET FOR ALL OTHER INSTALLATIONS.**

			1455 KLEPPE LANE SPARKS, NEVADA 89431 (775) 359-4712 FAX (775) 359-7424 E-MAIL: HAWS@HAWS.CO.COM WEBSITE: WWW.HAWS.CO.COM		
			ECN: 5551	REV. ECN: 5637	BY: FV
DRAWN: LF	DATE: 07/30/20	CHKD: DP			REVISION 2
APPROVED: FV	DATE: 01/12/21	SCALE: 1:4	DRAWING TYPE: INSTALLATION	SIZE: A	SHEET 3 OF 4

**ALL ELECTRICAL WORK TO BE DONE PER LOCAL CODE**

PROXIMITY SWITCHES ARE RATED TO 3 AMPS DC,  
VOLTAGE 0-120 VAC or 0-28 VDC, 100VA  
AMBIENT TEMPERATURE -40°C (-40°F) TO 72°C (161.6°F)

**SP152S**

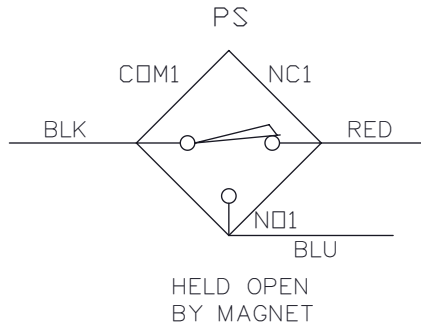

**SP152D**

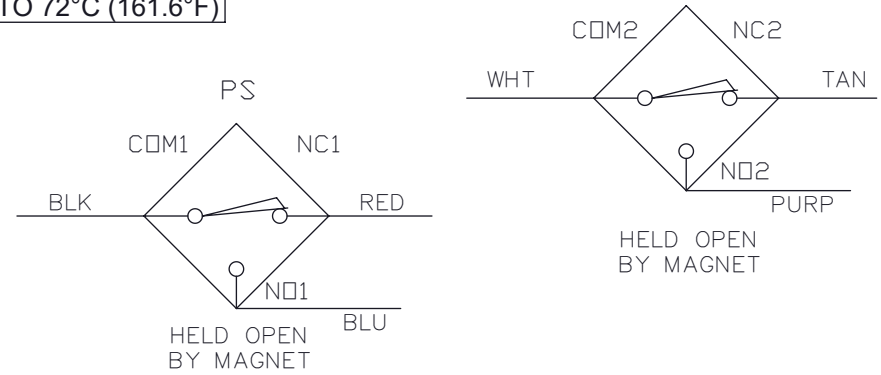

**SP152SC**

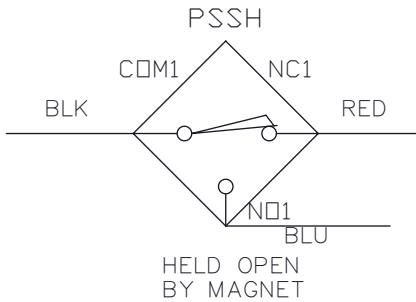

**ELECTRICAL WIRING OF PROXIMITY SWITCH(ES)**

**SP152DC**

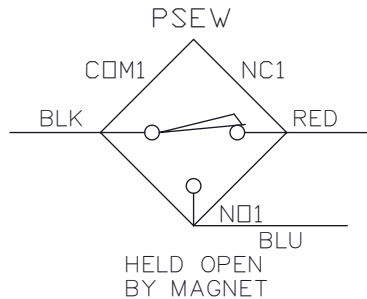
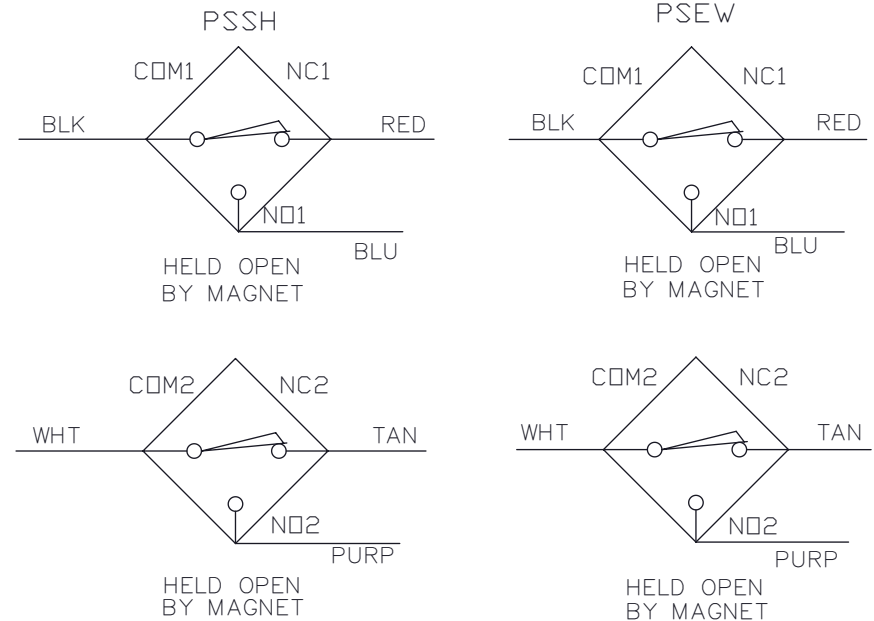

**LEGEND:**

BLK - BLACK  
BLU - BLU  
COM - COMMON  
PS - PROXIMITY SWITCH  
PSSH - PROXIMITY SWITCH, SHOWER  
PSEW - PROXIMITY SWITCH, EYEWASH  
PURP - PURPLE  
NO - NORMALLY OPEN  
NC - NORMALLY CLOSED  
WHT - WHITE



1455 KLEPPE LANE  
SPARKS, NEVADA 89431  
(775) 359-4712 FAX (775) 359-7424  
E-MAIL: HAWS@HAWS.CO.COM  
WEBSITE: WWW.HAWS.CO.COM

ECN: 5551	REV. ECN: 5637	BY: FV	MODEL(S)	PART NUMBER
DRAWN: LF	DATE: 07/30/20	CHKD: DP	SP152S/SP152D/SP152SC/SP152DC	0510001049.D
APPROVED: FV	DATE: 01/12/21	SCALE: 1:12	DRAWING TYPE: INSTALLATION	REVISION
			SIZE: A	2
				SHEET 4 OF 4