

FEATURES & BENEFITS

CONSTRUCTION

Rugged ADA accessible 18 gauge Type 304 high polished stainless steel swirl design bowls, 14 gauge Type 304 high polished stainless Steel brackets, and vandal-resistant bottom plates provide a long lasting unit with added peace of mind.

HANDS FREE

Touchless operation for safety and peace of mind.

BACK PANEL

Stainless steel back panel helps to protect the wall from inadvertent splashing, and its decorative satin finish increases location visibility.

MOUNTING

3/16" (.47 cm) thick steel mounting plate is larger, thicker and stronger than any other plate in the industry, and shall include the all-thread studs, nuts, and washers which allows for easy installation to a framed wall. (P-trap and stop require rear access)

BUBBLER HEADS

Polished chrome-plated brass bubbler heads with integral laminar flow prevents splashing while providing a superior flow pattern. The integral 11/16" dia. basin shank and stainless anti-rotation roll pin for vandal resistance strength. Shielded, angled stream opening provides a steady source of drinking water at .45 gpm.

FOUNTAIN VALVES

Fountain incorporates touchless sensor operated stainless steel solenoid valves controlled by a transformer for handsfree operation. A pressure regulator is used to adjust the bubbler flow according to incoming water pressures.

VANDAL RESISTANT

The bubbler heads, sensors, round bowls, drain strainers and bottom plates are locked in place, discouraging unwanted vandal tampering, and 30-second obstruction time-out to reduce tampering of sensors.



SPECIFICATIONS

Model 1011HPSH02 ADA vandal-resistant wall mounted motion activated drinking fountain shall include dual 18 gauge Type 304 polished stainless steel basins with integral swirl design, 14 gauge Type 304 polished stainless steel wall brackets, touchless sensor operated stainless steel solenoid valves with 30-second obstruction time-out controlled by a transformer, 100% lead-free waterways, polished chrome-plated brass vandal-resistant bubbler heads with integral laminar anti-squirt flow, chrome-plated brass vandal-resistant waste strainers, vandal-resistant bottom plates, polished stainless steel back panel, high and low fountain mounting levels, and 1-1/4" O.D. (3.2 cm) waste pipes. (P-trap and stop require rear access)

REQUIRES MODEL 6700.4 PRICED SEPARATELY.

FOR INDOOR USE ONLY

APPLICATIONS

Perfect for either public or private indoor/outdoor settings, Model 1011HPSH02 is a great fit in areas where aesthetics are important to the overall appeal of the architecture. This series is precisely mounted, making it a nice addition to any surrounding. Beautiful satin finish helps to maintain the fountains overall appeal, so it always remains looking as new as it did when it was installed. Specifically, this type of wall mounted drinking fountain may be placed in settings such as: schools and other locations in and around office buildings where the temperature remains above freezing. Model meets all current Federal Regulations for the disabled including those in the Americans with Disabilities Act. Haws manufactures drinking fountains, faucets and electric water coolers to be lead-free by all known definitions including NSF/ANSI/CAN 61- Section 9, NSF/ANSI/CAN 372, California Proposition 65, and the Federal Safe Drinking Water Act. Product is compliant to California Health and Safety Code 116875 (AB 1953-2006), and 116876 (AB 100) "NSF/ANSI/CAN 61: Q ≤ 1".

OPTIONS

- Bottle Filler: Model 1920HPSHO, bottle filler can be a standalone station, or mounted above Haws 1001HPS and 1011HPS series drinking fountain models.
- Water Filter: Model 6426, 12" x 2" (30.5 x 5.1 cm), in-line lead removal element that reduces lead from incoming water supply.
- Back Panel: Model BP15HPS, high polished stainless steel 15 inch back panel for Model 1920HPS.
- Support Frame: Model 6800 In-wall floor mounted fixture support legs, welded steel 4-bolt floor flanges, and supplied with 'U' bolts and hardware.

For more information, visit www.hawsco.com or call (888) 640-4297.



NOTES:

1. HOLD ROUGH-IN DIMENSIONS $\pm 1/8"$ (3.2mm).
2. WHEN INSTALLING THIS UNIT, LOCAL, STATE, OR FEDERAL CODES SHOULD BE ADHERED TO FOR INSTALLATION DIMENSIONS (LOCATIONS), WASTE AND SUPPLY REQUIREMENTS OTHER THAN SHOWN.
3. INSTALLER MUST PROVIDE TRAP FOR PROPER INSTALLATION.
4. REMOVE VALVE FROM PUSH BUTTON TO INSTALL WASTE ELBOW ONTO BOWL. AFTER WASTE ELBOW IS INSTALLED, REINSTALL VALVE AND ADJUST FLOW.
5. REFER TO 5874 SERIES OPERATION AND MAINTENANCE MANUAL FOR PUSH BUTTON AND VALVE INSTALLATION/MAINTENANCE INSTRUCTIONS.
6. REFER TO 1RKHO.H & 2RKHO.H OPERATION AND MAINTENANCE INSTRUCTIONS FOR TRANSFORMER AND SENSOR SETUP.

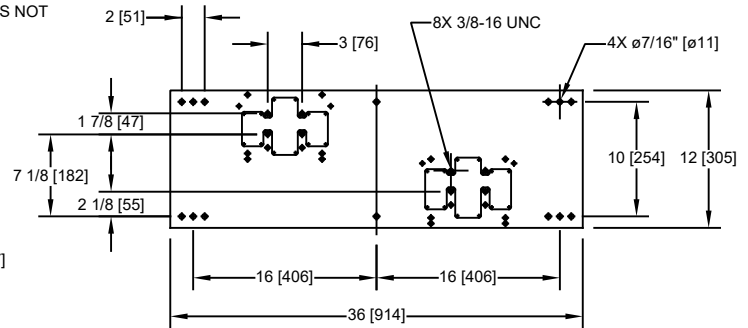
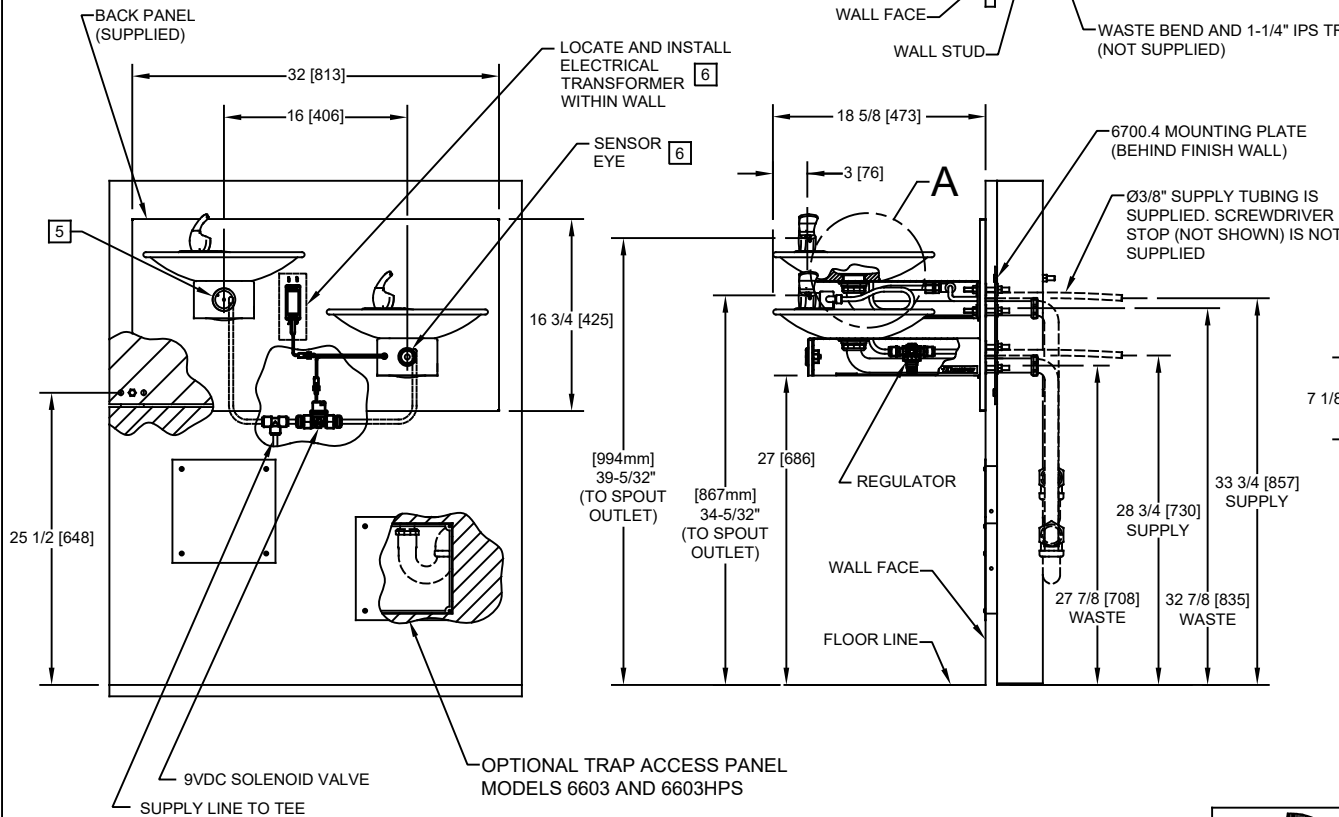
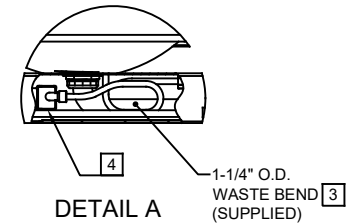
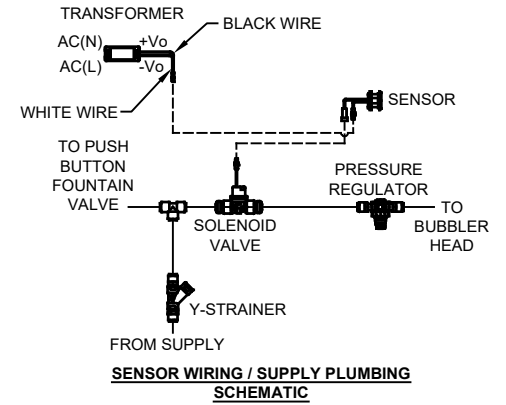
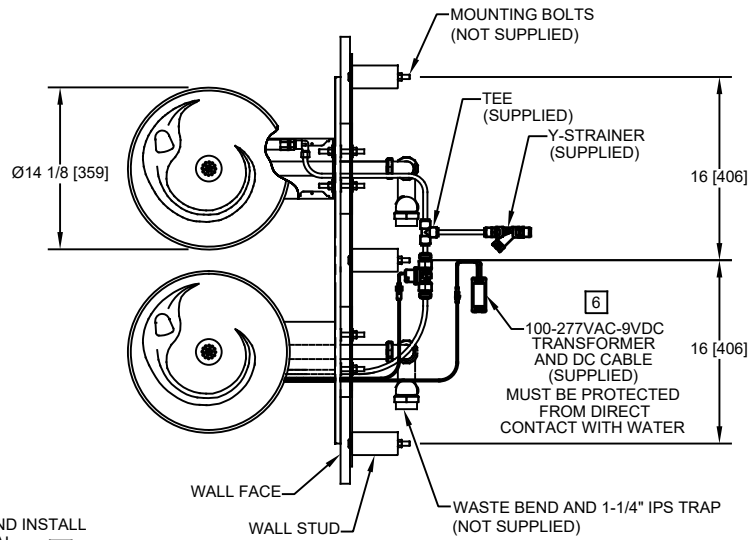

**6700.4 MOUNTING PLATE
MUST BE INSTALLED BEFORE FINISH WORK.
THIS PLATE IS REQUIRED - SOLD SEPARATELY.**

MODEL 1011HO/1011HPSHO SHOWN
MODEL 1011HO2/1011HPSHO2 ON SHEET 2
(ROUGH-IN DIMENSIONS APPLY TO ALL 4 MODELS)

1455 KLEPPE LANE
SPARKS, NEVADA 89431
(775) 359-4712 FAX (775) 359-7424
E-MAIL: HAWS@HAWSCO.COM
WEBSITE: WWW.HAWSCO.COM

ECN NO. 5579		REVISED PER ECN: 5678		BY: DP		MODEL(S)		PART NUMBER	
DRAWN: FV		DATE: 09/15/20		CHKD: FV		1011HO/1011HO2/1011HPSHO/1011HPSHO2		0510001066.D	
APPROVED: BJM		DATE: 04/23/21		SCALE: 1:1		DRAWING TYPE: INSTALLATION		REVISION: 2	
				SIZE: A		SHEET 1 OF 2			

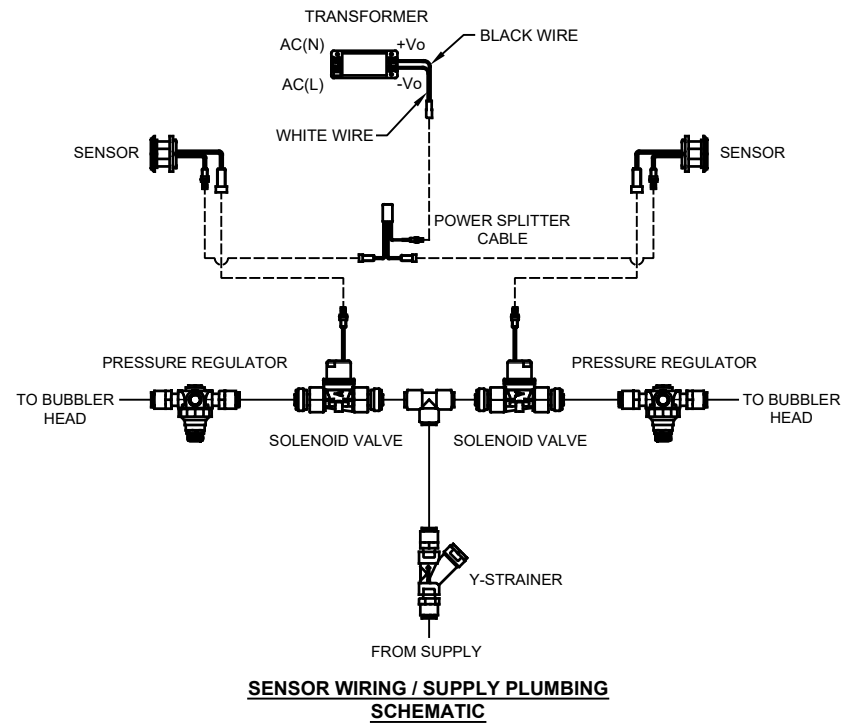
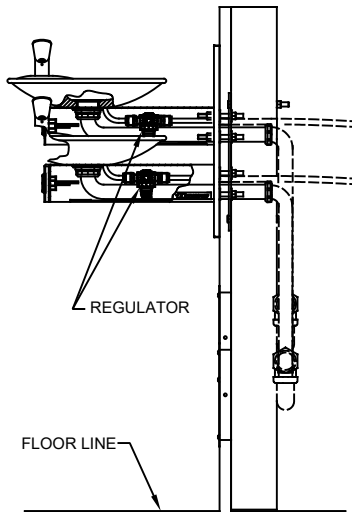
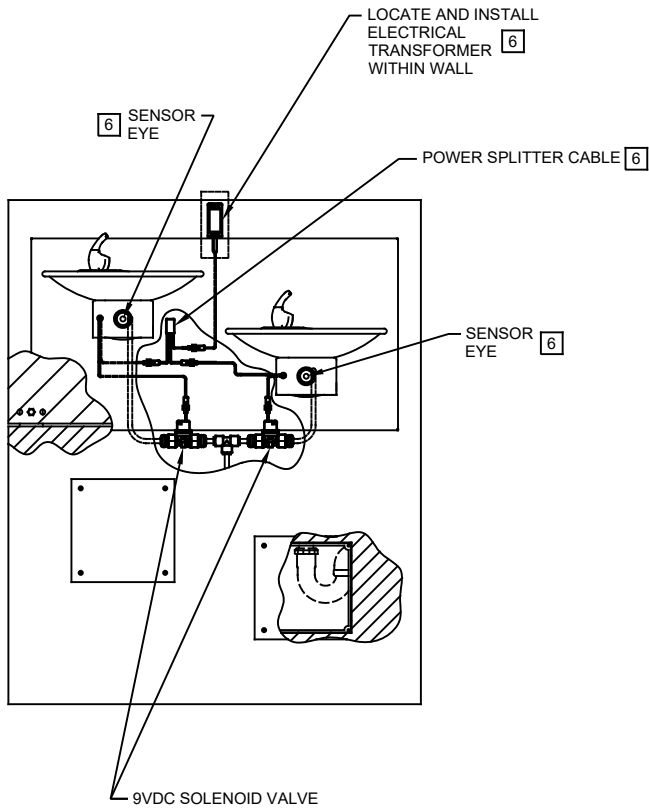
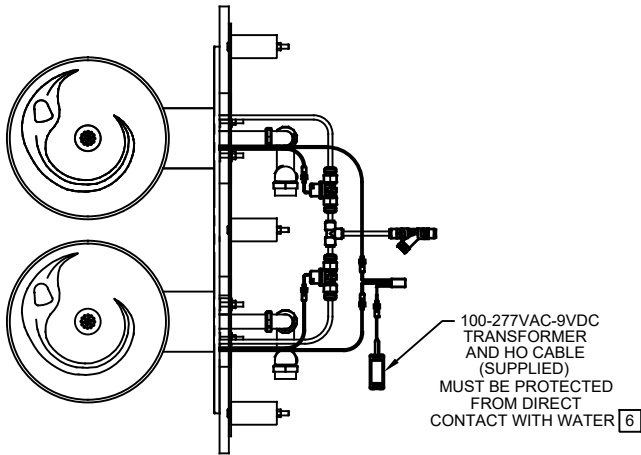

MODEL 1011HO2/1011HPSHO2 SHOWN
 MODEL 1011HO/1011HPSHO ON SHEET 1
 (SEE SHEET 1 FOR APPLICABLE ROUGH-IN DIMENSIONS)

		Haws [®]		1455 KLEPPE LANE SPARKS, NEVADA 89431 (775) 359-4712 FAX (775) 359-7424 E-MAIL: HAWS@HAWSCO.COM WEBSITE: WWW.HAWSCO.COM	
				ECN NO. 5579 DRAWN: FV APPROVED: BJM	REVISED PER: ECN: 5678 DATE: 09/15/20 DATE: 04/23/21
SCALE: 1:1		DRAWING TYPE: INSTALLATION		SIZE: A SHEET 2 OF 2	