

NOTES:

1. HOLD ROUGH-IN DIMENSIONS  $\pm 1/4"$  (6.4mm).
2. WHEN INSTALLING THIS UNIT, LOCAL, STATE, OR FEDERAL CODES SHOULD BE ADHERED TO.

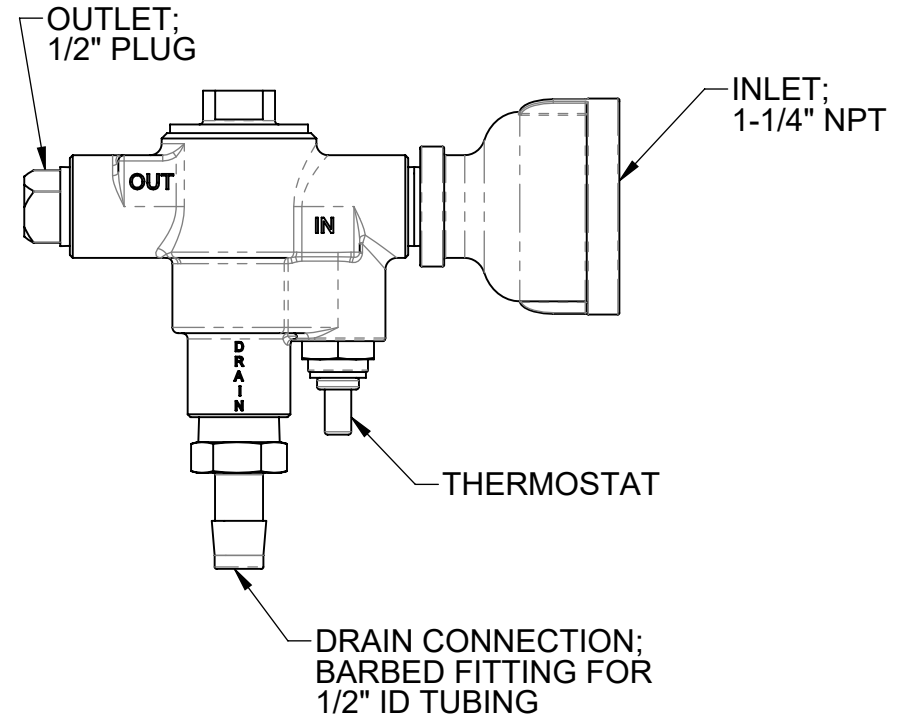
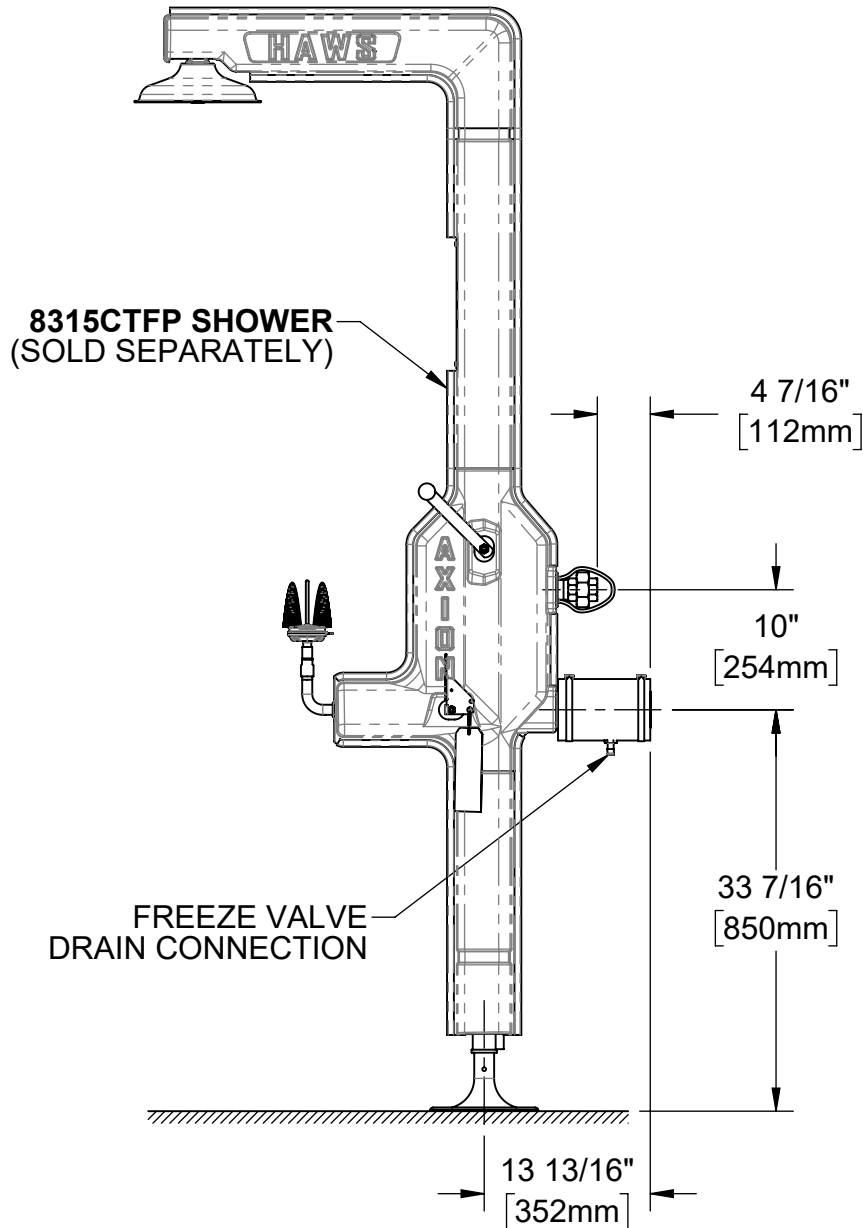

**FACTORY-ASSEMBLED VALVE SECTION**  
(WITHOUT INSULATION, ZIP TIES,  
OR ADDITIONAL PLUMBING)

**SP158.15 STANDALONE INSTALLATION**  
(FOR USE IN CONJUNCTION WITH THE SP121,  
CONSULT THE SP121 DOCUMENTATION)

				1455 KLEPPE LANE SPARKS, NEVADA 89431 (775) 359-4712 FAX (775) 359-7424 E-MAIL: HAWS@HAWS.CO.COM WEBSITE: WWW.HAWS.CO.COM	
				ECN: 5588 DRAWN: JL APPROVED: JL	REV. ECN: 5661 DATE: 09/17/20 DATE: 04/19/21
SCALE: N/A		DRAWING TYPE: INSTALLATION		SIZE: A	SHEET 1 OF 1