

NOTES:

1. BUTTON RELOCATION PLATE MAY BE INSTALLED IN PLACE OF ANY BLANK ACCESS COVER OF THE SAME SIZE.
2. INSTALLATION REQUIRES REMOVAL OF EXISTING PET BOWL VALVE AND RE-INSTALLATION OF VALVE INTO BUTTON RELOCATION PLATE AS SHOWN HERE.
3. IT IS RECOMMENDED THAT THE PET BOWL FOUNTAIN BE ROTATED SUCH THAT THE RESULTING OPEN VALVE HOLE IS AGAINST THE PEDESTAL TO CONCEAL/BLOCK THE HOLE.

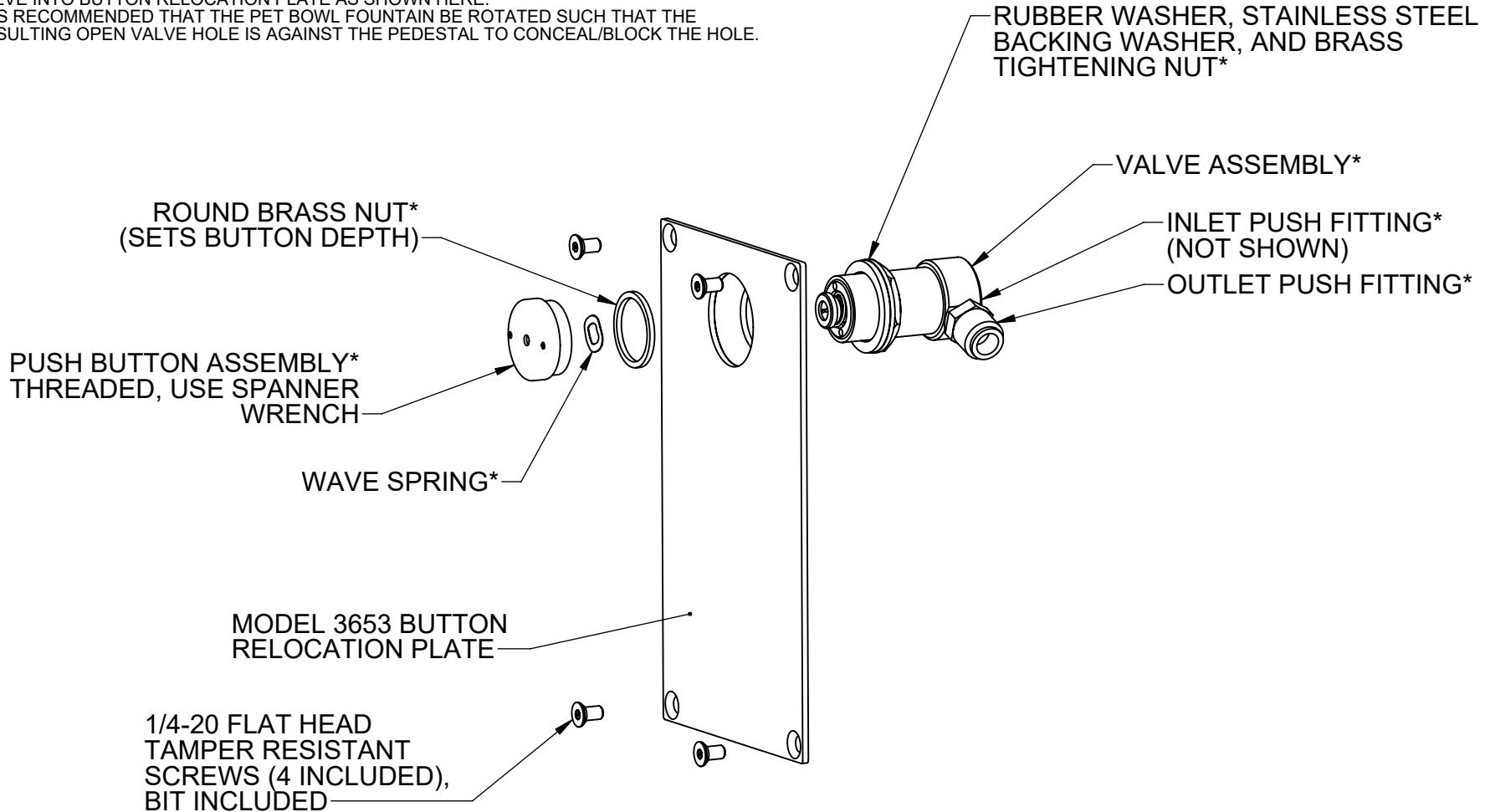

ITEMS INCLUDED BUT NOT SHOWN

| UNSHOWN INCLUDED ITEM | QTY | NOTES |
|---------------------------|-----|---------------------------------------------------------|
| SPANNER WRENCH | 1 | LOOSEN/TIGHEN PUSH BUTTON ASSEMBLY |
| 5/32 TAMPER RESISTANT BIT | 1 | REMOVE/INSTALL 1/4-20 TAMPER RESISTAN SCREWS |
| PUSH CONNECT COUPLER | 1 | CONNECT OUTLET TUBING TO BUBBLER SUPPLY TUBING |
| PUSH CONNECT TEE | 1 | CONNECT INTO WATER SUPPLY TUBING |
| 3/8" LOW PRESSURE TUBING | 36" | FROM VALVE OUTLET TO BUBBLER SUPPLY TUBING (CUT TO FIT) |
| 3/8" HIGH PRESSURE TUBING | 24" | FROM SUPPLY TEE TO VALVE INLET (CUT TO FIT) |

* EXISTING PART



1455 KLEPPE LANE
SPARKS, NEVADA 89431
(775) 359-4712 FAX (775) 359-7424
E-MAIL: HAWS@HAWS.CO.COM
WEBSITE: WWW.HAWS.CO.COM

| | | | | |
|--------------|----------------|------------|-------------------------------------------------------------|---------------|
| ECN: 5561 | REV. ECN: 5561 | BY: DP | MODEL(S) MODEL 3653 PET FOUNTAIN BUTTON RELOCATION PLATE | PART NUMBER |
| DRAWN: DHP | DATE: 08/26/20 | CHKD: FV | | 0580001067 |
| APPROVED: FV | DATE: 09/05/20 | SCALE: 1:8 | DRAWING TYPE: INSTALLATION | REVISION 1 |
| SHEET 1 OF 1 | | | SIZE: A | |