

## FEATURES & BENEFITS

### HANDS OFF

Touchless operation for safety and peace of mind.

### CONSTRUCTION

Rugged ADA accessible 18 gauge Type 304 Stainless Steel swirl design bowl, 14 gauge Type 304 Stainless Steel bracket, and a vandal-resistant bottom plate provides a long lasting unit with added peace of mind.

### QUALITY CONTROL

Pre-built fountain is pressure tested to ensure no leaks and proper functionality.

### VANDAL RESISTANT

The bubbler head, round bowl, drain strainer and bottom plate are locked in place, discouraging unwanted vandal tampering.

### BUBBLER HEAD

Polished chrome-plated brass bubbler head with integral laminar flow prevents splashing while providing a superior flow pattern. The integral 11/16" dia. basin shank and stainless anti-rotation roll pin for vandal resistance strength. Shielded, angled stream opening provides a steady source of drinking water at .45 gpm.

### DRINKING FOUNTAIN VALVE

Fountain incorporates a touchless sensor operated stainless steel solenoid valve controlled by a transformer for hands-free operation. A pressure regulator is used to adjust the bubbler flow according to incoming water pressures.

### MOUNTING

Heavy-duty 16-gauge galvanized steel mounting frame with welded-in heavy-duty 10 gauge mounting plate with pre-punched mounting holes. Further convenience is given to the chiller with the integral fold-out shelf.

## OPTIONS

- Bottle Filler: Model 1920HO, touchless bottle filler can be a stand-alone station, or mounted above Haws 1001 series drinking fountain models.
- Back Panel: Model BP15, satin finish stainless steel 15 inch back panel for Model 1920HO.
- Bottle Filler Stand: Model BTL1001, add-on stainless steel stand to place bottle on when 1920HO bottle filler is used.

For more information, visit [www.hawsc.com](http://www.hawsc.com) or call (888) 640-4297.



## SPECIFICATIONS

Model H1001.8HO electric vandal-resistant ADA wall mounted motion activated drinking fountain shall include an 18 gauge Type 304 Stainless Steel satin finish basin with integral swirl design, 14 gauge Type 304 Stainless Steel wall bracket, 100% lead-free waterways, touchless sensor operated stainless steel solenoid valve with 30-second obstruction time-out controlled by a transformer, polished chrome-plated brass vandal resistant bubbler head with integral laminar anti-squirt flow, chrome-plated brass vandal-resistant waste strainer, vandal-resistant bottom plate, stainless steel satin finish back panel and louvered intrusion-proof grill, and 1-1/4" O.D. (3.2 cm) waste pipe. The R-134a refrigeration system is hermetically sealed and delivers a minimum of 8 gph (30.3 L) of water at 50° F (10° C) cooled from 80° F (26.7° C) inlet water at 90° F (32.2° C) ambient. 115 Volts, 60Hz, rated watts: 370, full load amps: 5

**REQUIRES MODEL HCR8 AND MTGFR.SM PRICED SEPARATELY.**

**FOR INDOOR USE ONLY**

## APPLICATIONS

This series is precisely mounted, making it a nice addition to any surrounding. Specifically, this type fountain may be placed in settings such as: schools, office buildings, shopping malls, and other indoor environments where there is a demand for a chilled water source and/or wheelchair access. Electric water coolers are not recommended or designed for outdoor applications or enclosed pool areas (chlorine). These conditions may void warranty. Model meets all current Federal Regulations for the disabled including those in the Americans with Disabilities Act. Haws manufactures drinking fountains, faucets and electric water coolers to be lead-free by all known definitions including NSF/ANSI/CAN 61- Section 9, NSF/ANSI/CAN 372, California Proposition 65, and the Federal Safe Drinking Water Act. Product is compliant to California Health and Safety Code 116875 (AB 1953-2006), and 116876 (AB 100) "NSF/ANSI/CAN 61:  $Q \leq 1$ ". Haws electric water coolers comply with ARI Standard 1010 and ANSI A117.1, and are listed by Underwriter Laboratories to U.S. and Canadian standards.



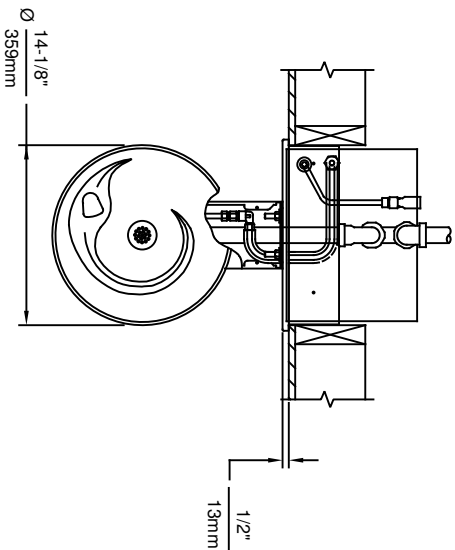

Available with hands off sensor  
in lieu of push button

- NOTES:**
- HOLD ROUGH-IN DIMENSIONS  $\pm 1/8"$  (3.2mm).
  - WHEN INSTALLING THIS UNIT, LOCAL, STATE, OR FEDERAL CODES SHOULD BE ADHERED TO. FOR DIMENSIONS (LOCATIONS), WASTE AND SUPPLY REQUIREMENTS, OTHER THAN SHOWN, DIMENSIONS MARKED (\*) MUST BE ADJUSTED ACCORDINGLY.
  - INSTALLER MUST PROVIDE TRAP FOR PROPER INSTALLATION.
  - REFER TO 5874SS OPERATION AND MAINTENANCE MANUAL FOR PUSH BUTTON AND VALVE INSTALLATION/MAINTENANCE INSTRUCTIONS.
  - REFER TO MTGR-SM INSTALLATION DRAWING FOR ROUGH-IN DIMENSIONS.
  - INSERT 5/16"-18 PANEL INSERTS FROM OPPOSITE SIDE AT LOCATIONS SHOWN BY DARKENED HOLES.
  - FOUNTAIN REMOVAL: FIRST REMOVE SCREWS AND THEN SQUEEZE CLIPS ON NUT RETAINER TO POP OUT. INSTALL IS REVERSE OF REMOVAL.
  - ALIGN HOLES IN CHILLER SUPPORT TRAY WITH HOLES IN FRAME AND FASTEN WITH #10 SHEET METAL SCREWS.

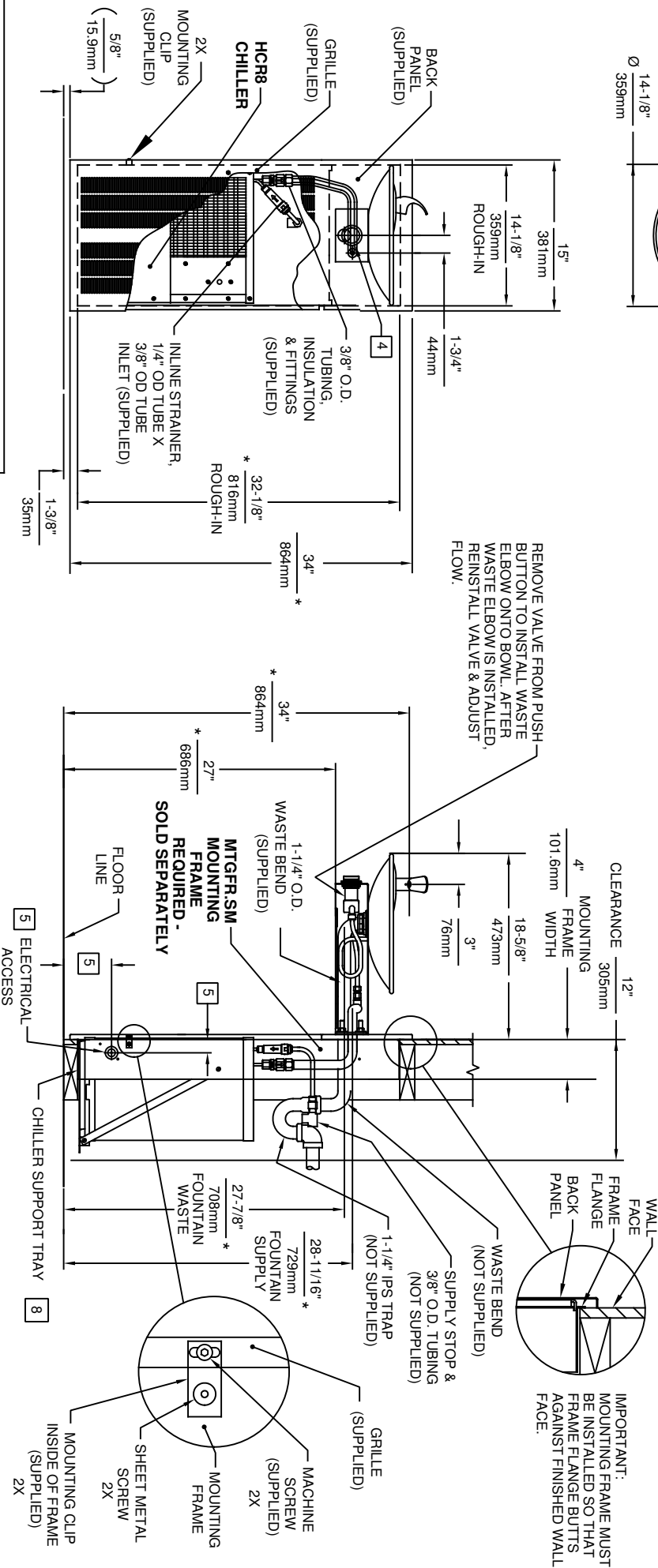

REMOVE VALVE FROM PUSH BUTTON ONTO BOWL. AFTER ELBOW ONTO BOWL, AFTER WASTE ELBOW IS INSTALLED, REINSTALL VALVE & ADJUST FLOW.



**BOWL MOUNTING PATTERN DETAIL**

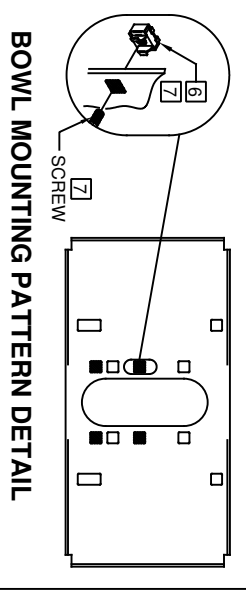

		<b>MODEL(S)</b>	
1456 KLEPPE LANE SPARKS, NEVADA 89431 (775) 359-4712 FAX (775) 359-7424 E-MAIL: HAWS@HAWS.CO.COM WEBSITE: WWW.HAWS.CO.COM		H1001.8/H1001.8HPS	
ECN NO. REVISED PER BY:	ECN: 5527	DATE:	07/31/97
DRAWN:	RTM	CHKD:	DP
APPROVED:	EV	DATE:	04/02/20
SCALE: 1:15		DRAWING TYPE: INSTALLATION	
PART NUMBER: 0002080246.D		REVISION: 20	

**NOTES:**

1. HOLD ROUGH-IN DIMENSIONS ±1/8" (3.2mm).
2. WHEN INSTALLING THIS UNIT, LOCAL, STATE, OR FEDERAL CODES SHOULD BE ADHERED TO FOR INSTALLATION DIMENSIONS (LOCATIONS), WASTE AND SUPPLY REQUIREMENTS OTHER THAN SHOWN.
3. INSTALLER MUST PROVIDE TRAP FOR PROPER INSTALLATION.
4. REFER TO 1RKH01H OPERATION AND MAINTENANCE INSTRUCTIONS FOR TRANSFORMER AND SENSOR SETUP.

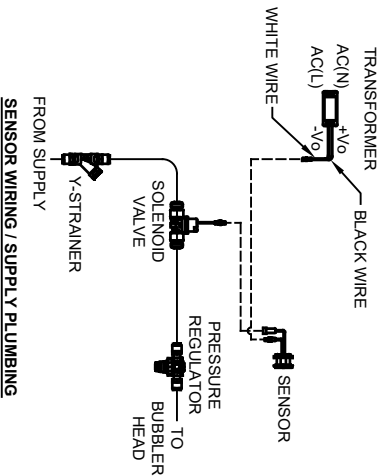

**SENSOR WIRING / SUPPLY PLUMBING SCHEMATIC**

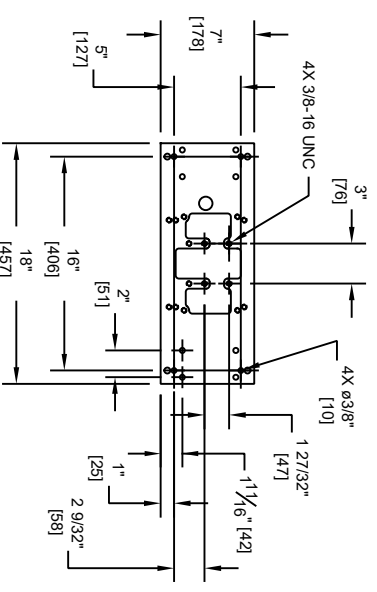
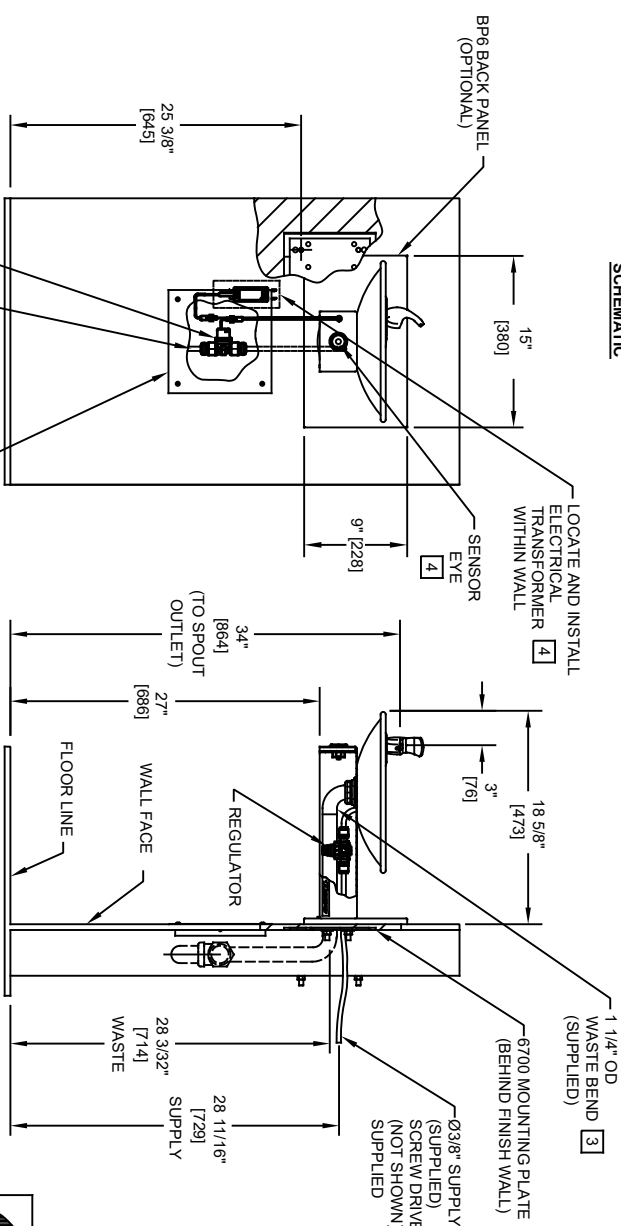
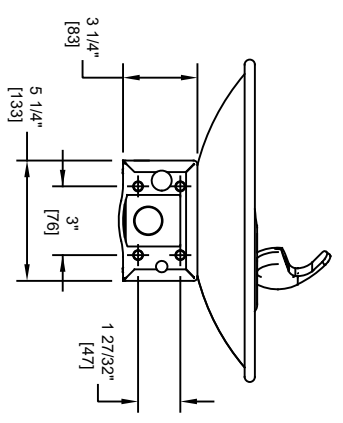
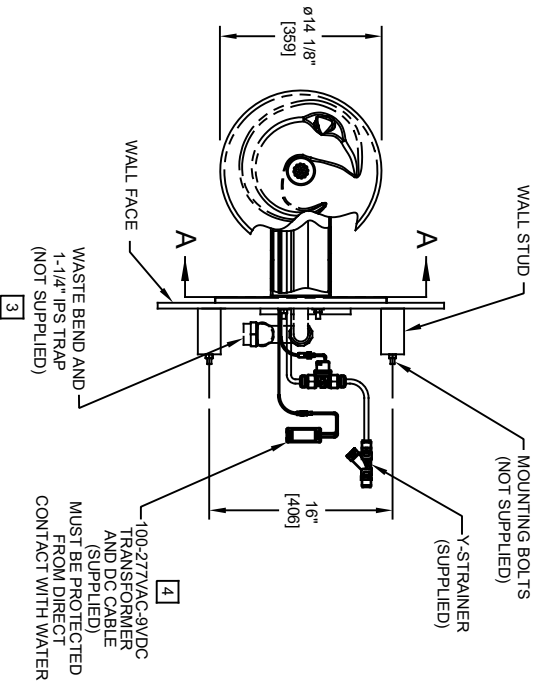

**6700 MOUNTING PLATE**  
MUST BE INSTALLED BEFORE FINISH WORK  
THIS PLATE IS REQUIRED - SOLD SEPARATELY.

**Haws**

1456 KLEPPE LANE  
SPARKS, NEVADA 89431  
(775) 359-4712 FAX (775) 359-7424  
E-MAIL: HAWS@HAWSCO.COM  
WEBSITE: WWW.HAWSCO.COM

ECN NO. REVISED PERBY: MODEL(S)  
DRAWN: ECN: 5733 FV: 1001HO  
DATE: 09/28/21 CHKD: BMM  
FV: 09/28/21 BMM

APPROVED: FV: 09/30/21

SCALE: 1:1 DRAWING TYPE: INSTALLATION

SIZE: A SHEET: 1 OF 1

PART NUMBER: 0510002020.D  
REVISION: 1