



model 9400LPS

AXION® low-pressure steam water heater

OPERATION

When an emergency shower or eyewash is activated, the flow of water opens a steam control valve. The steam enters a brazed plate heat exchanger, instantly heating the water. A mixing valve blends hot and cold water to produce an output of 80° F (27° C) tepid water. Additional valves keep the system preheated, freeze protected and scald protected. The steam valve will remain closed should there be a loss of water pressure.

FEATURES & BENEFITS

FLOW RATES

Provides 3 to 25 GPM (11 to 95 LPM) of tepid water.

OPERATION

Low pressure system operates on typical plant steam pressure, 15-30 PSIG (1-2 BAR) is recommended. Steam and water never mix, separated by brazed plate heat exchanger.

DESIGNED TO MEET ASSE 1071 REQUIREMENTS

Unit employs a paraffin filled thermostatic mixing element with the lowest internal pressure drop where supply pressure is low. The modular brass design with a one piece casting uses internal check stops, oversized valve seats, a shuttle design that eliminates valve sticking, and a funnel design to improve temperature control with better mixing at low flow rates.

INSTALLATION

Ease of installation, uses existing plant steam and water supply. Union connections are provided for quick installation. Compact, lightweight design, easily supported by pipe connections.

SERVICING

Durable, protective enclosure can be readily removed for servicing.

MEDICALLY SUPERIOR RESPONSE®

AXION's superior design and technology provide a complete safety solution for increased victim comfort.



SPECIFICATIONS

Model 9400LPS – Low-Pressure Steam Water Heater

| | MAXIMUM | | MINIMUM | |
|---|---|--------|---------|--------|
| | | | | |
| Outlet Flow Rate | 25 GPM | 95 LPM | 3 GPM | 11 LPM |
| Ambient Operating Temperature | 120° F | 49° C | -30° F | -34° C |
| Inlet Water Pressure | 90 PSIG | 6 BAR | 55 PSIG | 4 BAR |
| Inlet Water Temperature | 80° F | 27° C | 40° F | 4° C |
| Inlet Steam Pressure | 30 PSIG | 2 BAR | 15 PSIG | 1 BAR |
| Steam Temperature | 350° F | 177° C | | |
| Cold Water Bypass Flow Rate | 24 GPM @ 25 PSI Pressure Drop | | | |
| Water Inlet & Outlet Pipe Size | 1 1/4" NPT (F) | | | |
| Steam Supply & Condensate Pipe Size | 1" NPT (F) | | | |
| Steam Consumption | 600 lb/hr @ 25 GPM Flow Rate, 20 lb/hr @ Idle | | | |
| Condensate Discharge Rate | 12 GPH maximum | | | |
| Pressure Drop Water Inlet to Water Outlet | 25 PSI @ 25 GPM | | | |

NOTES:

1. DIMENSIONAL TOLERANCES: ±1/2".
2. RECOMMENDED WATER PRESSURE:
55 psi (3.79 bar) MIN.
90 psi (6.21 bar) MAX.
3. MODEL 9400:
RECOMMENDED SATURATED STEAM PRESSURE:
45 psi TO 60 psi (3.10 bar TO 4.14 bar)
MAXIMUM SATURATED STEAM TEMPERATURE:
350° F (177° C)
4. MODEL 9400LPS:
RECOMMENDED SATURATED STEAM PRESSURE:
15 psi TO 30 psi (1.03 bar TO 2.07 bar)
MAXIMUM SATURATED STEAM PRESSURE:
274° F (134° C) @ 30 psi (2.07 bar)
250° F (121° C) @ 15 psi (1.03 bar)

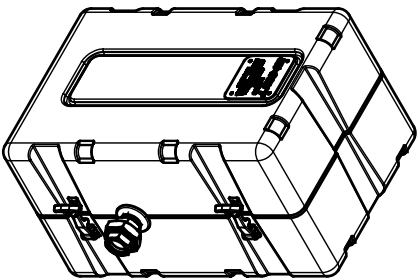

MODEL 9400 SHOWN

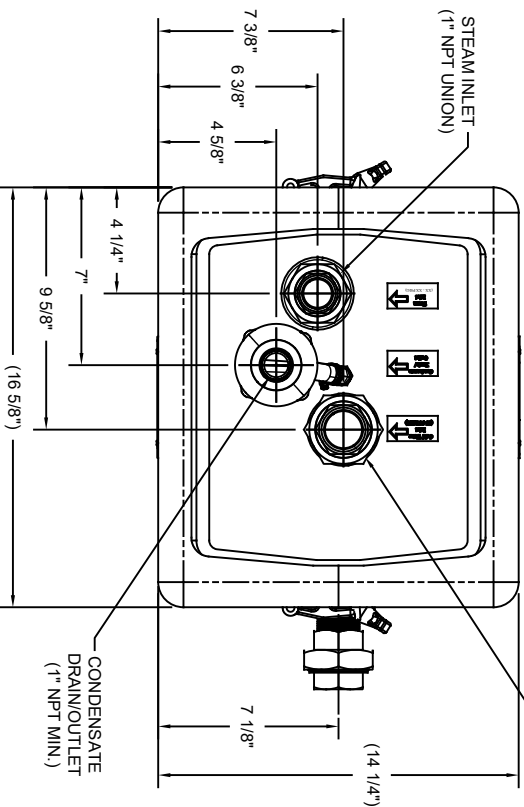
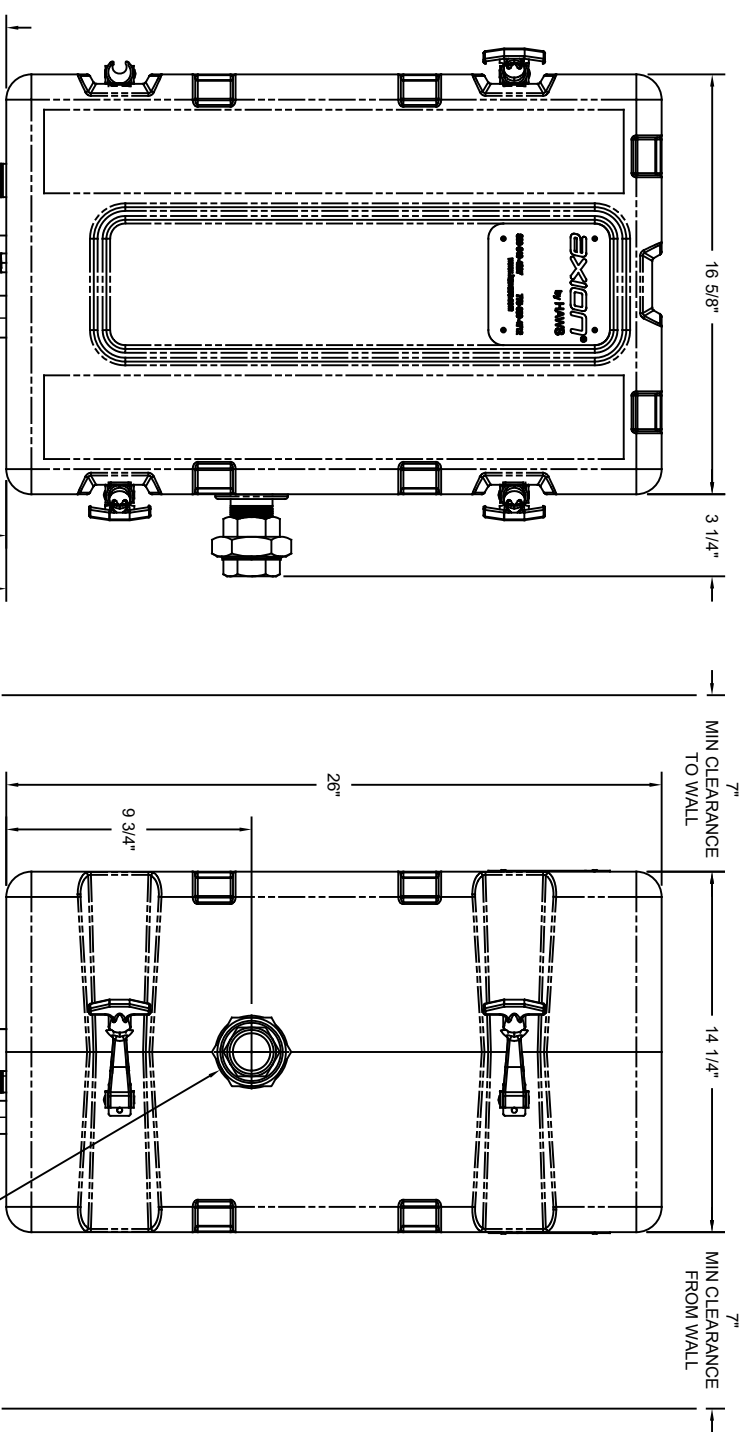

COLD WATER INLET
(1 1/4" NPT UNION)

DRAIN LINE WITH
AIR GAP FITTING
(1" NPT MIN.)

TEMPERED WATER OUTLET
(1 1/4" NPT UNION)
3 MIN DISTANCE TO
SAFETY SHOWER

| | | | |
|---|--------------|---------------------------------|--------------|
| | | Haws | |
| 1456 KLEPPE LANE SPARKS, NEVADA 89431 (775) 359-4712 FAX (775) 359-7424 E-MAIL: HAWS@HAWSCO.COM WEBSITE: WWW.HAWSCO.COM | | MODEL(S) 9400/9400LPS | |
| ECN NO. REVISED PER BY: | 4930 | ECN. 5741 | FV |
| DATE: | 10/01/14 | CHKD: | BMM |
| APPROVED: | FV | DATE: | 11/1/21 |
| SCALE: | NA | DRAWING TYPE: | INSTALLATION |
| PART NUMBER | 0002080243.D | REVISION: | 11 |