



# model 1117LHO

ADA Vandal-Resistant Motion-Activated/Push Button Dual Adjustable Fountain

## FEATURES & BENEFITS

### INTEGRATED TRAP

All cast brass 1-1/4" NPT adjustable traps completely concealed inside bottom plates for easy installation and lack of unwanted access.

### BARRIER-FREE CONFIGURABLE

Supplied with a low profile bowl, individual adjustable panels, and multiple mounting positions, this fountain can be configured for adult and child ADA considerations.

### BUBBLER HEADS

Polished chrome-plated brass bubbler heads with integral 11/16" dia. basin shank and stainless anti-rotation roll pin for vandal resistance strength. Shielded, angled stream opening provides a steady, sanitary source of drinking water at .45 gpm.

### DRINKING FOUNTAIN VALVES

Fountain incorporates a touchless sensor operated stainless steel solenoid valve controlled by a transformer on one side and a push-button activated valve which offers the only all stainless steel valve body that is machined out of solid bar stock and is fully serviceable through the front of the push button assembly offering access to the water control cartridge and integral water supply strainer on the other.

### VANDAL-RESISTANT

The bubbler heads, push button, drain strainers and bottom plates are locked in place, discouraging unwanted vandal tampering.

### CONSTRUCTION

One-piece drinking fountains with low-profile design made of 14 gauge Type 304 stainless steel with 1/4" (.6 cm) thick stainless back plates welded in, and vandal-resistant stainless bottom plates. Satin finish resists stains and corrosion.

### TAMPER RESISTANT

30-second obstruction time-out to reduce tampering of sensor.



## SPECIFICATIONS

Model 1117LHO low profile ADA vandal-resistant wall mounted combination motion-activated/push-button adjustable drinking fountain shall include dual 14-gauge Type 304 Stainless Steel satin finish basins with integral 1/4" (.6 cm) thick stainless-steel back plates, touchless sensor operated solenoid valve with 30-second obstruction time-out on one side, and vandal-resistant push-button operated stainless steel valve with front-accessible cartridge and flow adjustment on the other, 100% lead free waterways, polished chrome-plated brass vandal-resistant bubbler heads, polished chrome-plated brass vandal-resistant waste strainers, vandal-resistant bottom plates, stainless steel satin finish back panel, adjustable mounting allowing either basin high or low, in-wall mounting plate, and 1-1/4" NPT concealed all cast-brass traps. The patented design allows the unit to be mounted to meet ADA or Child ADA specifications.

**REQUIRES MODEL 6717 PRICED SEPARATELY.**

**FOR INDOOR USE ONLY**

## OPTIONS

Custom Logo Panel: Model 6475, Hydration By Haws™ logo panel with customization options.

Cane Detection, Floor Mounted: Model SK6, floor mounted cane detection for the Haws Hi-Lo drinking fountains.

Remote Drinking Fountain Water chiller: Model HCR8, 8 gph (30.3 L) remote water chiller provides instantaneous cooling to meet a continuous demand for chilled water.

Bottle Filler: Model 1920HO, bottle filler can be a stand-alone station, or mounted above Haws 1001, 1011, 1107L, 1109, 1117L, and 1119 series drinking fountain models.

For more information, visit [www.hawasco.com](http://www.hawasco.com) or call (888) 640-4297.



## APPLICATIONS

Perfect for either public or private indoor settings, Model 1117LHO is a great fit in areas where aesthetics are important to the overall appeal of the architecture. Beautiful satin finish helps to maintain the fountains overall appeal. Specifically, this type of wall mounted drinking fountain may be placed in settings such as: schools and other locations in and around office buildings. Model meets all current Federal Regulations for the disabled including those in the Americans with Disabilities Act. Haws manufactures drinking fountains, faucets and electric water coolers to be lead-free by all known definitions including NSF/ANSI/CAN 61- Section 9, NSF/ANSI/CAN 372, California Proposition 65, and the Federal Safe Drinking Water Act. Product is compliant to California Health and Safety Code 116875 (AB 1953-2006), and NSF/ANSI/CAN 61: Q ≤ 1.



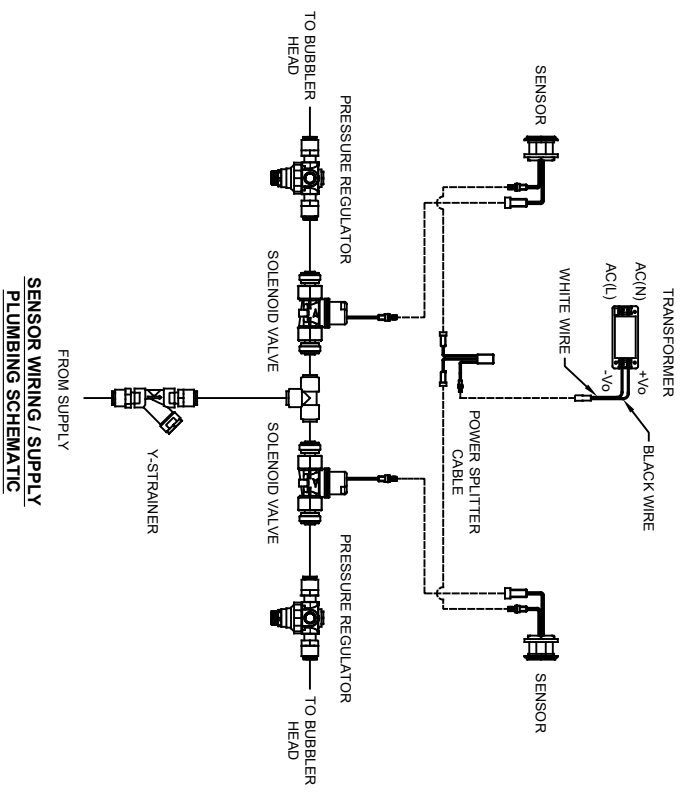
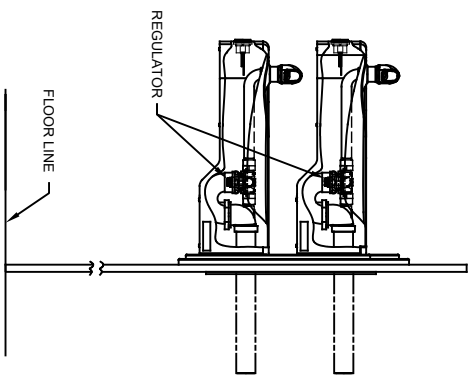
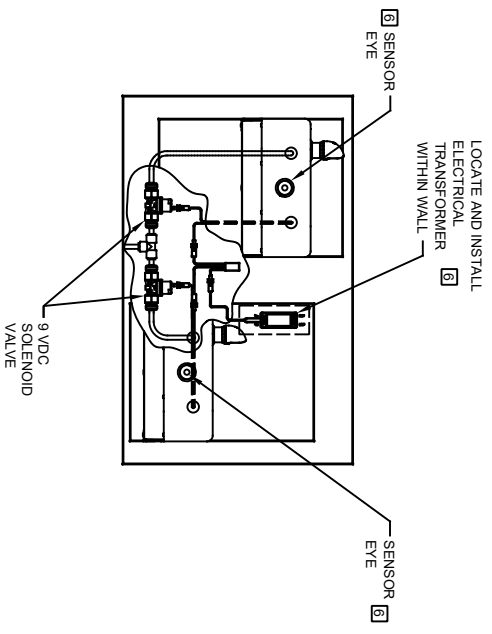
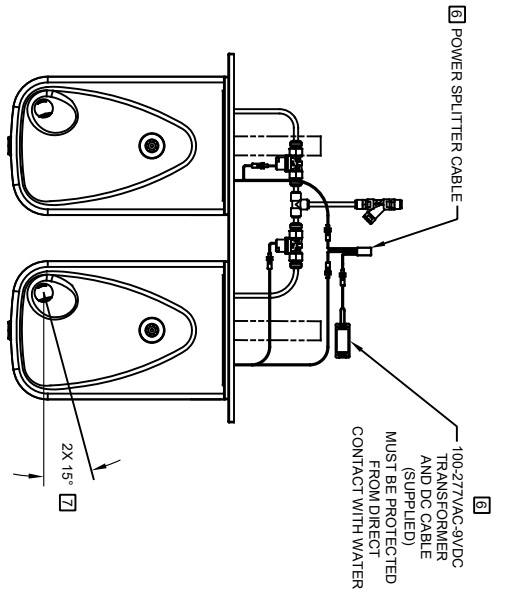

MODEL 1117LHO2 SHOWN  
 MODEL 1117LHO ON SHEET 1  
 (SEE SHEET 1 FOR APPLICABLE ROUGH-IN DIMENSIONS)

**Haws**

1459 KLEPPE LANE  
 SPARKS, NEVADA, 89431  
 (775) 359-4712 FAX (775) 359-7424  
 E-MAIL: HAWS@HAWS.CO.COM  
 WEBSITE: WWW.HAWS.CO.COM

ECN NO. REVISED PER BY: MODEL(S)  
 5712 ECN: 5712 FV: 1117LHO/1117LHO2

DATE: 07/21/21  
 CHK'D: DP

SCALE: 1/2 DRAWING TYPE: INSTALLATION

SIZE: A SHEET 2 OF 3

REVISION: 1

PART NUMBER: 0510001209.D

**NOTES:**

- 8 FIGURES 1 AND 2 ARE REVERSIBLE. CAN BE RIGHT OR LEFT SIDE HIGH.
- 9 USE SHADED HOLES TO MOUNT AT INDICATED POSITIONS BASED ON COMBINATION SELECTED (FIGS. 1 THRU 3).
- 10. REFER TO SHEET 1 OF 3, NOTE 4, FOR INSTALLED FOUNTAIN DIMENSIONS.

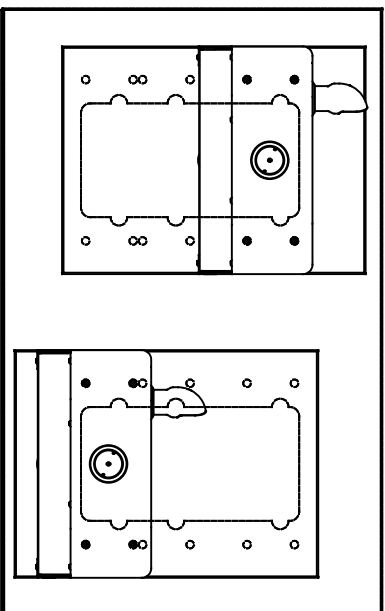

FIGURE 1.

ADULT STANDING/CHILD WHEELCHAIR

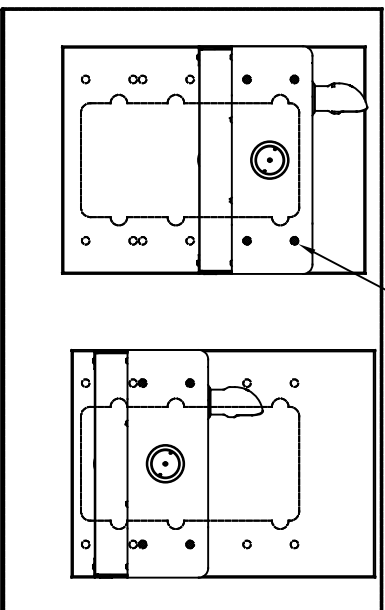

FIGURE 2.

ADULT STANDING/ADULT WHEELCHAIR

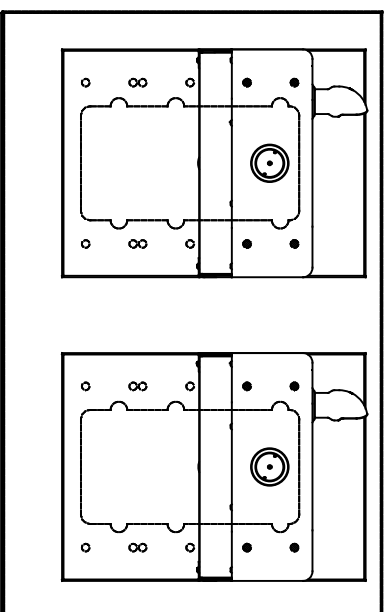

FIGURE 3.

ADULT STANDING/ADULT STANDING

# BOWL MOUNTING PATTERNS



**Haws**

1459 KLEPPE LANE  
SPARKS, NEVADA 89431  
(775) 359-4712 FAX (775) 359-7424  
E-MAIL: HAWS@HAWSCO.COM  
WEBSITE: WWW.HAWSCO.COM

ECN NO. REVISED PER BY:	MODEL(S)	PART NUMBER
5712		0510001209.D
DATE:	DATE:	REVISION:
07/21/21	07/21/21	1
APPROVED:	SCALE:	SIZE:
FV	1:2	A
	DRAWING TYPE:	SHEET 3 OF 3
	INSTALLATION:	