

## FEATURES & BENEFITS

### CONSTRUCTION

Unit is made of 18 gauge Type 304 stainless steel with a satin finish that resists stains and corrosion, and has soft, rounded corners. Unit features stainless steel satin finish back panel, vandal-resistant bottom plate, and 1-1/4" integral trap.

### QUALITY CONTROL

Pre-built fountain is pressure tested to ensure and proper functionality.

### BUBBLER HEAD

Polished chrome-plated brass bubbler head with integral 11/16" dia. basin shank and stainless anti-rotation roll pin for vandal resistance strength. Shielded, angled stream opening provides a steady, sanitary source of drinking water at .45 gpm.

### FOUNTAIN VALVE

Fountain incorporates a touchless sensor operated stainless steel solenoid valve controlled by a transformer for handsfree operation. A pressure regulator is used to adjust the bubbler flow according to incoming water pressures.

### VANDAL RESISTANT

The bubbler head, drain strainer and bottom plate are locked in place, discouraging unwanted vandal tampering.

### TAMPER RESISTANT

30-second obstruction time-out to reduce tampering of sensor.

### INTEGRATED TRAP

All cast brass 1-1/4" NPT adjustable trap completely concealed inside bottom plate for easy installation and access.

## OPTIONS

- Remote Drinking Fountain Water chiller: Model HCR8, 8 gph (30.3 L) remote water chiller provides instantaneous cooling to meet a continuous demand for chilled water.
- Mounting Plate: Model 6700 universal mounting plate for most wall mounted fountains.
- Support Frame: Model 6800 universal in-wall mounting support for use with most fountains.
- Bottle Filler: Model 1920HO, bottle filler mounted above Haws 1105 fountain.

For more information, visit [www.hawsco.com](http://www.hawsco.com) or call (888) 640-4297.



## SPECIFICATIONS

Model 1105HO wall mounted vandal-resistant motion activated drinking fountain shall include an 18 gauge Type 304 Stainless Steel satin finish basin, touchless sensor operated stainless steel solenoid valves with 30-second obstruction time-out controlled by a transformer, 100% lead-free waterways, polished chrome-plated brass vandal-resistant bubbler head, polished chrome-plated brass vandal-resistant waste strainer, vandal-resistant bottom plate, and 1-1/4" NPT trap.

### FOR INDOOR USE ONLY

## APPLICATIONS

Perfect for either public or private indoor/outdoor settings, Model 1105HO is a great fit in areas where aesthetics are important to the overall appeal of the architecture. Beautiful satin finish helps to maintain the fountains overall appeal. Specifically, this type of wall mounted drinking fountain may be placed in settings such as: schools and other locations in and around office buildings where the temperature remains above freezing. Haws manufactures drinking fountains, faucets and electric water coolers to be lead-free by all known definitions including NSF/ANSI/CAN 61- Section 9, NSF/ANSI/CAN 372, California Proposition 65, and the Federal Safe Drinking Water Act. Product is compliant to California Health and Safety Code 116875 (AB 1953-2006), and NSF/ANSI/CAN 61: Q ≤ 1.



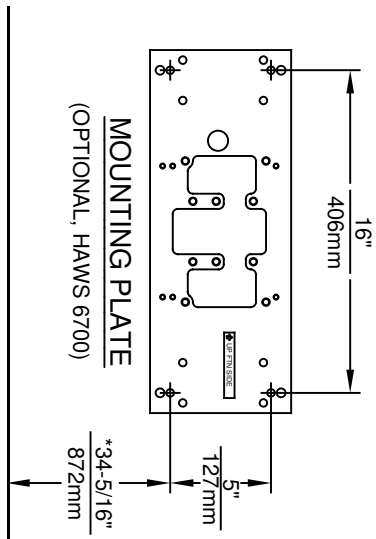
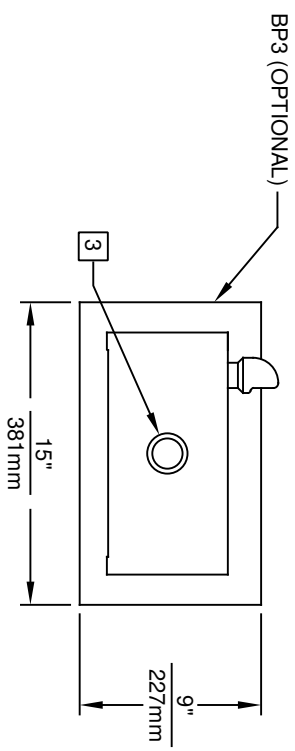
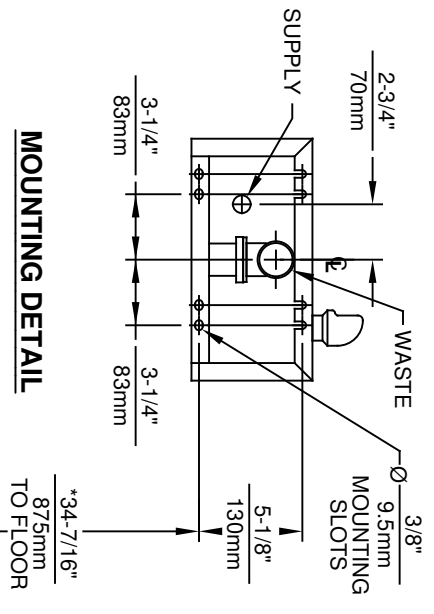
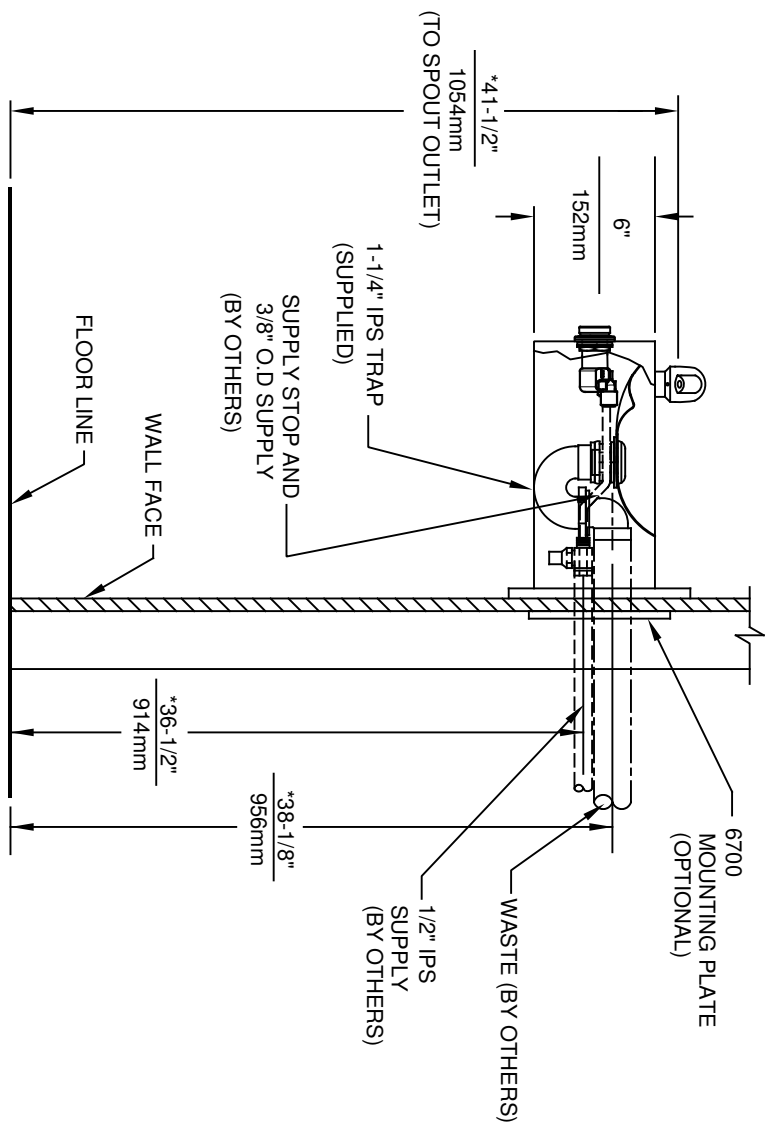
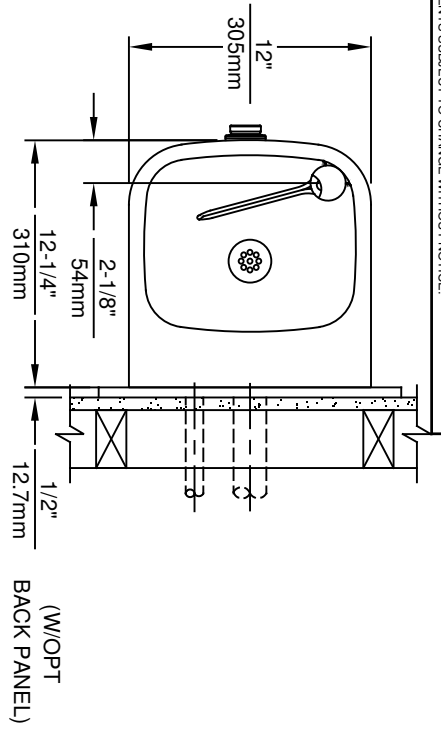

**NOTES:**

1. HOLD ROUGH-IN DIMENSIONS ± 1/4" (6.4mm).
2. WHEN INSTALLING THIS UNIT LOCAL, STATE OR FEDERAL CODES SHOULD BE ADHERED TO. FOR INSTALLATION HEIGHTS OTHER THAN SHOWN, DIMENSIONS MARKED (\*) MUST BE ADJUSTED ACCORDINGLY.
3. REFER TO 5874 SERIES OPERATION AND MAINTENANCE MANUAL FOR PUSH BUTTON AND VALVE INSTALLATION/MAINTENANCE INSTRUCTIONS.

		<b>MODEL(S)</b>	
1456 KLEPPE LANE SPARKS, NEVADA 89431 (775) 359-4712 FAX (775) 359-7424 E-MAIL: HAWS@HAWS.CO.COM WEBSITE: WWW.HAWS.CO.COM		1105	
ECN NO. REVISED PER BY:	ECN: 5215	DATE:	12/97
DRAWN:	JP	CHKD:	GC
APPROVED:		DATE:	11/22/17
SCALE:	NA	DRAWING TYPE:	INSTALLATION
SHEET:	1	OF:	1
PART NUMBER:	0002076524.D	REVISION:	18

**NOTES:**

- 1RKH0.P AND 1RKH0.H RETROFIT KITS ALLOW INDOOR FOUNTAINS TO BE CONVERTED FROM A HAWS 5874 PUSH BUTTON VALVE TO HANDS-OFF (TOUCHLESS) OPERATION. FOUNTAINS (NOT SUPPLIED) MAY BE MOUNTED ON THE EXTERNAL WALL OF A BUILDING PROVIDED THE TRANSFORMER SHALL BE MOUNTED INSIDE THE WALL AND PROTECTED FROM WATER AS SHOWN IN THIS INSTALLATION PER NEC/CEC AND LOCAL CODE. AVOID DIRECT CONTACT WITH SUNLIGHT ON THE SENSOR LENS.
- RETROFIT KIT MODELS:  
 1RKH0.P: INDOOR HO RETROFIT KIT (INCLUDES HO SENSOR WITH MOUNTING HARDWARE, SOLENOID VALVE, REGULATOR, AND 100-240V PLUG-IN TRANSFORMER - SEE SHEET 2).  
 1RKH0.H: INDOOR HO RETROFIT KIT (INCLUDES HO SENSOR WITH MOUNTING HARDWARE, SOLENOID VALVE, REGULATOR, AND 100-277V HARDWIRE TRANSFORMER - SEE SHEET 3).  
 1RKH0.P REQUIRES 100-240VAC POWER CONNECTION. 1RKH0.H REQUIRES 100-277V POWER CONNECTION.
- TRANSFORMERS MUST BE MOUNTED SUCH THAT THEY ARE PROTECTED FROM WATER.
- 1RKH0.P TRANSFORMER IS COMPATIBLE WITH TYPE A AND TYPE B NORTH AMERICAN ELECTRICAL OUTLETS. FOR OTHER RECEPTACLE TYPES, AN ADAPTER (NOT SUPPLIED) MUST BE PROVIDED BY OTHERS.

(NOTES CONTINUED ON SHEET 4)

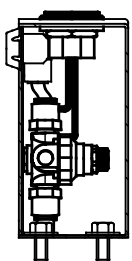

**EXAMPLE 1920 BOTTLE FILLER INSTALLATION**

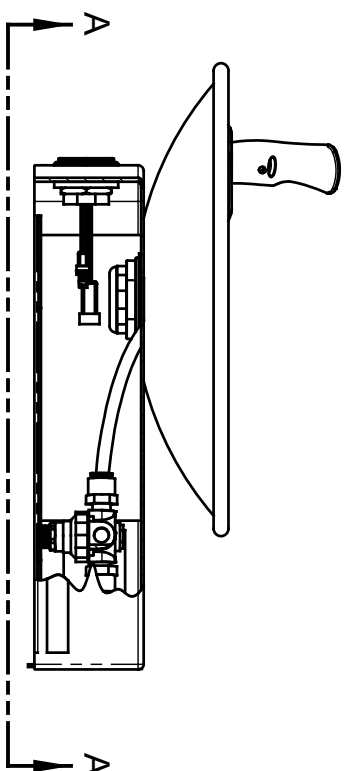

**EXAMPLE 1001 FOUNTAIN INSTALLATION**

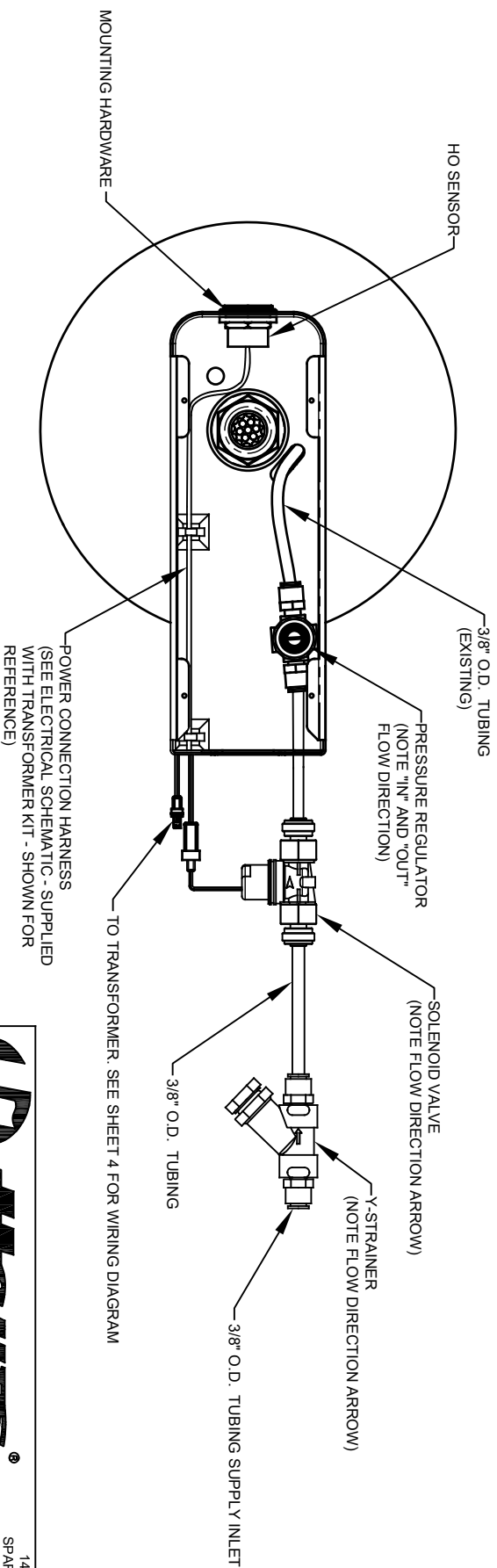

**VIEW A - A**

(BOTTOM PLATE OMITTED FOR CLARITY)



**Haws**

1459 KLEPPE LANE  
 SPARKS, NEVADA, 89431  
 (775) 359-4712 FAX (775) 359-7424  
 E-MAIL: HAWS@HAWS.CO.COM  
 WEBSITE: WWW.HAWS.CO.COM

ECN NO. REVISED PER BY:	MODEL(S)	PART NUMBER
5898 ECN: 5749 B.M.	1RKH0.P / 1RKH0.H	0580001133.D
DATE: CHKD:	SINGLE HANDS-OFF RETRO-FIT KIT	REVISION:
1/23/20 EV		5
APPROVED: B.M.	SCALE: N/A	DRAWING TYPE: INSTALLATION
DATE: 10/26/21		SIZE: A SHEET: 1 OF 4

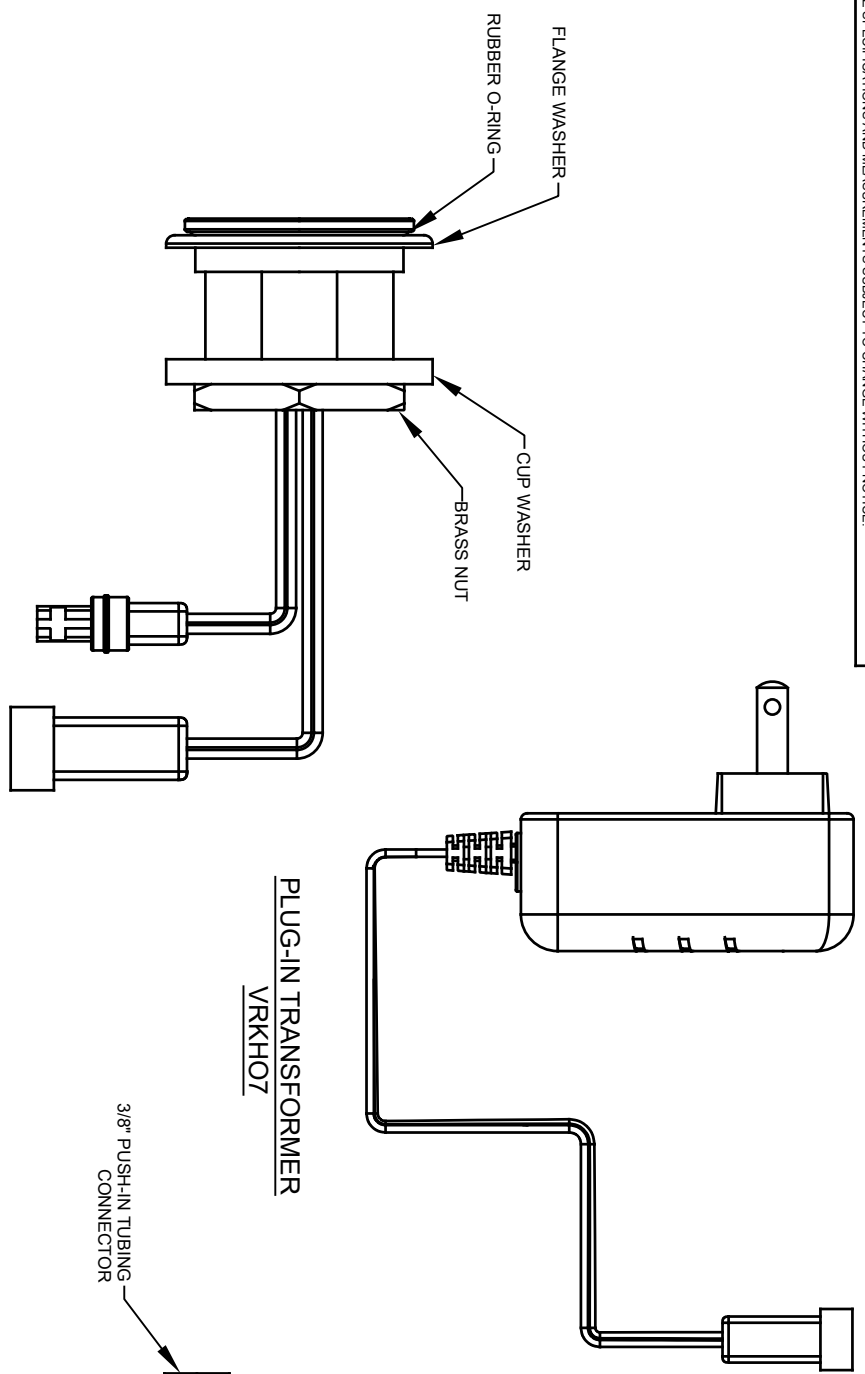

HO SENSOR ASSEMBLY  
VRKH06

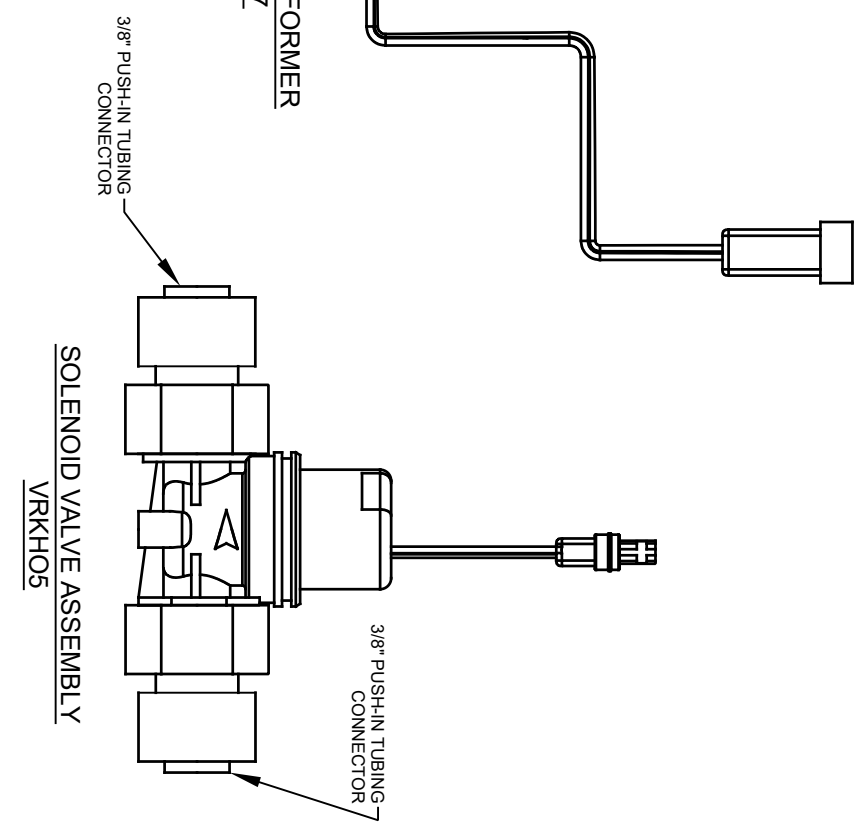

**1RKHO.P KIT - MAIN PARTS**

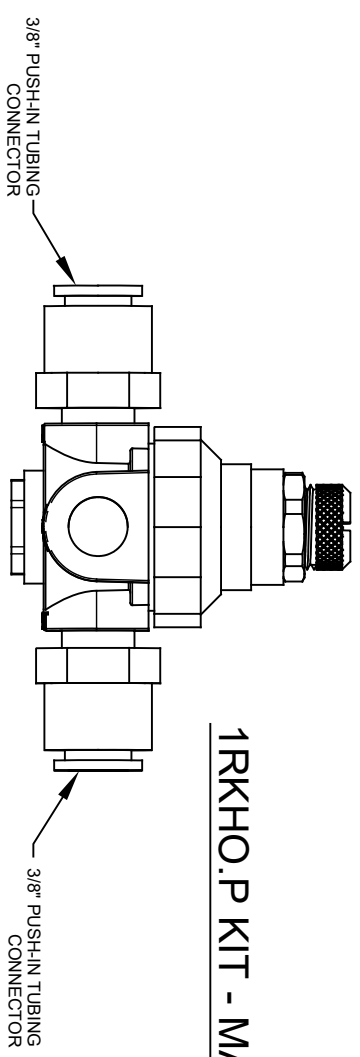

Y-STRAINER  
6433

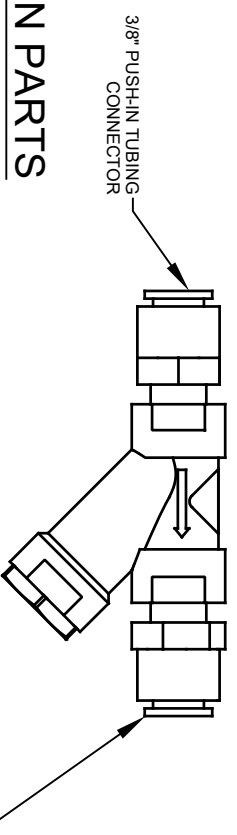

		<b>Haws</b>	
1459 KLEPPE LANE SPARKS, NEVADA, 89431 (775) 359-4712 FAX (775) 359-7424 E-MAIL: HAWS@HAWSCO.COM WEBSITE: WWW.HAWSCO.COM			
ECN NO. REVISED PER BY:	5898	ECN. 5749	BJM
DATE:	12/23/20	CHK'D:	FV
APPROVED:	BJM	SCALE:	N/A
DATE:	10/28/21	DRAWING TYPE:	INSTALLATION
SIZE:	A	SHEET:	2 OF 4
MODEL(S)	1RKHO.P / 1RKHO.H		
SINGLE HANDS-OFF RETRO-FIT KIT			
PART NUMBER	0580001133.D		
REVISION:	5		

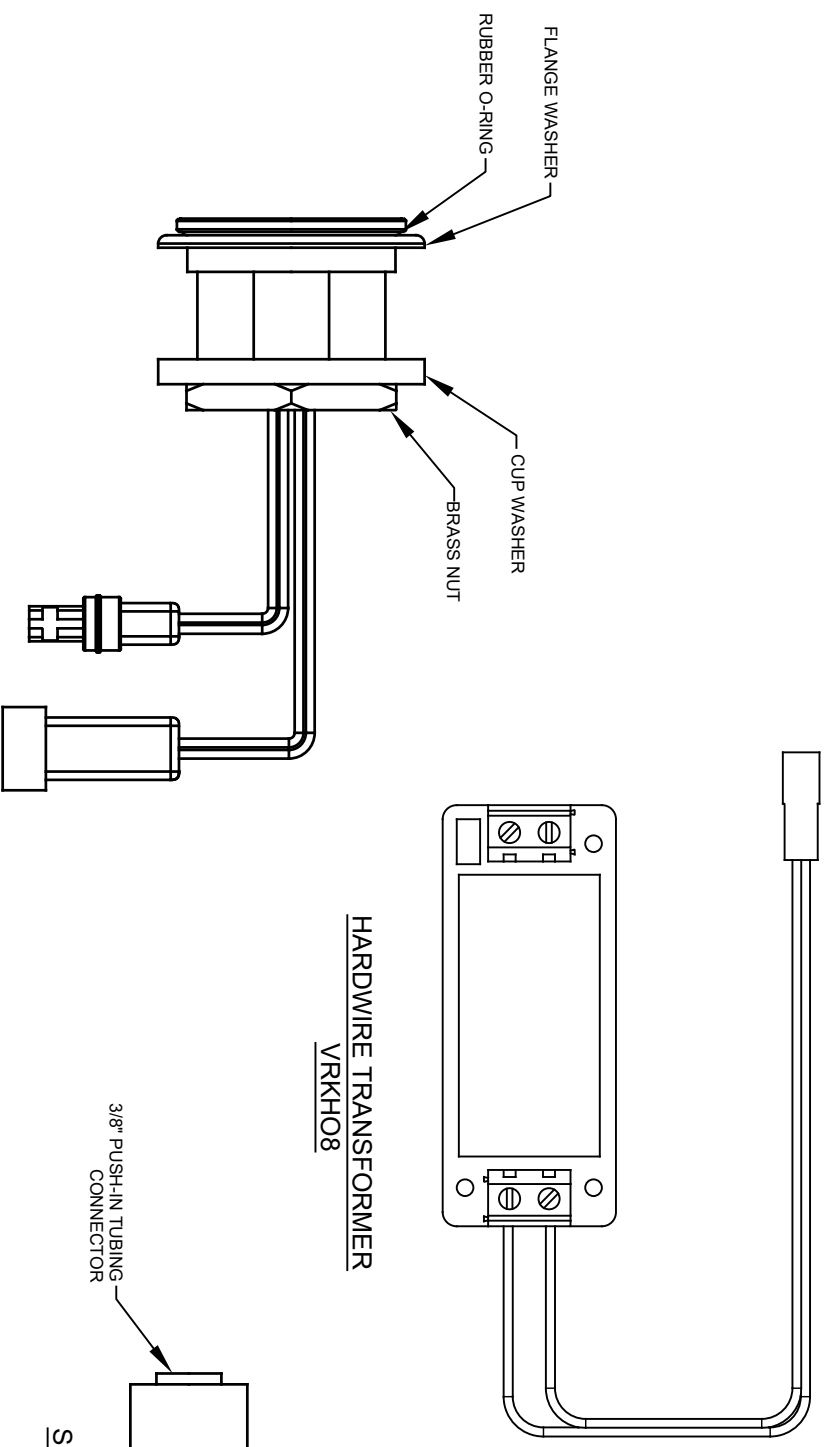

HO SENSOR ASSEMBLY  
VRKH06

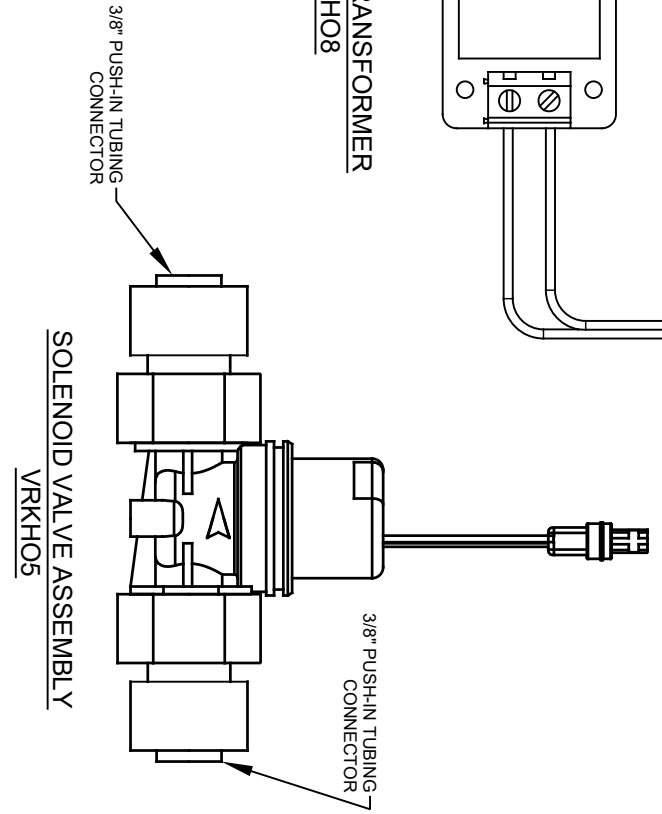

SOLENOID VALVE ASSEMBLY  
VRKH05

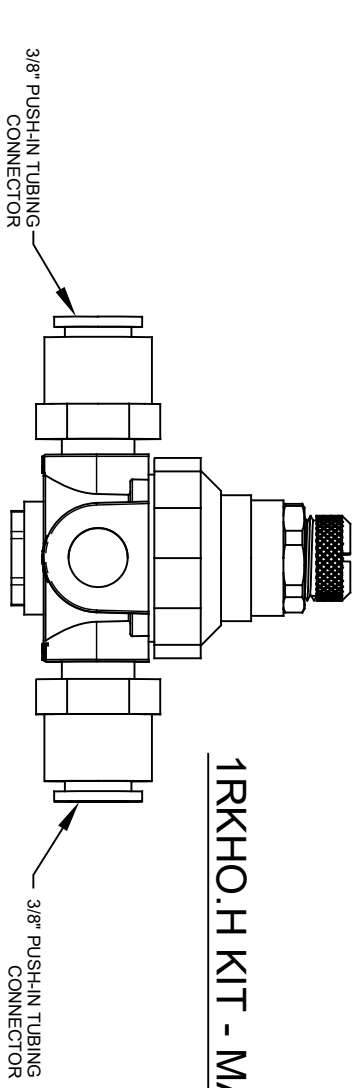

VALVE REGULATOR  
5867

**1RKHO.H KIT - MAIN PARTS**

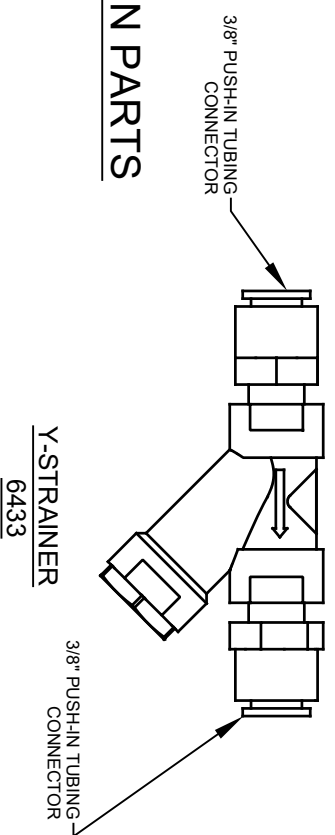

Y-STRAINER  
6433



**Haws**

1459 KLEPPE LANE  
SPARKS, NEVADA, 89431  
(775) 359-4712 FAX (775) 359-7424  
E-MAIL: HAWS@HAWSCO.COM  
WEBSITE: WWW.HAWSCO.COM

ECN NO. REVISED PER BY:	ECN NO. REVISED PER BY:	MODEL(S)	1RKHO.P / 1RKHO.H
5898	5749	DATE:	02/09/21
DATE:	02/09/21	SCALE:	N/A
DATE:	10/20/21	DRAWING TYPE:	INSTALLATION
DATE:	10/20/21	SIZE:	A
DATE:	10/20/21	SHEET:	3 OF 4
DATE:	10/20/21	REVISION:	4
DATE:	10/20/21	PART NUMBER:	0580001133.D
DATE:	10/20/21	REVISION:	4

NOTES (CONTINUED FROM SHEET 1):

- 6. 1RKHO.H TRANSFORMER WIRE RANGE: 24-12 AWG  
1RKHO.H TRANSFORMER TIGHTENING TORQUE: MAX 0.4 N\*m

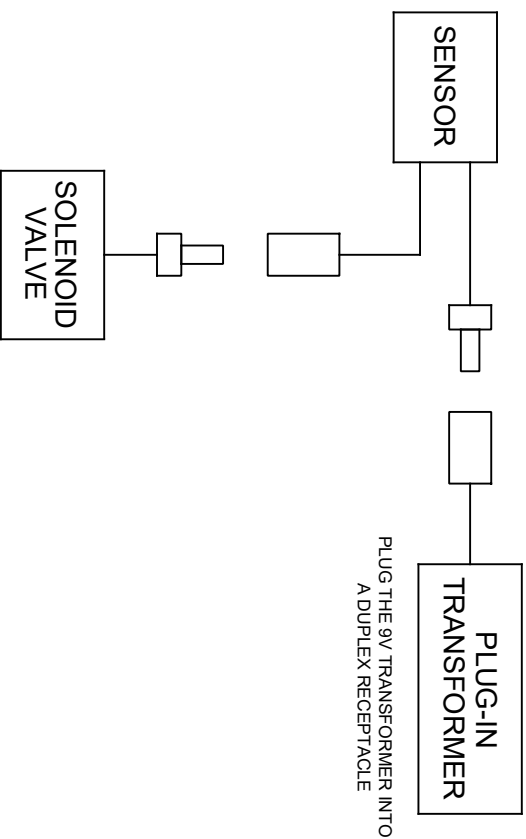

1RKHO.P CABLE WIRING SCHEMATIC

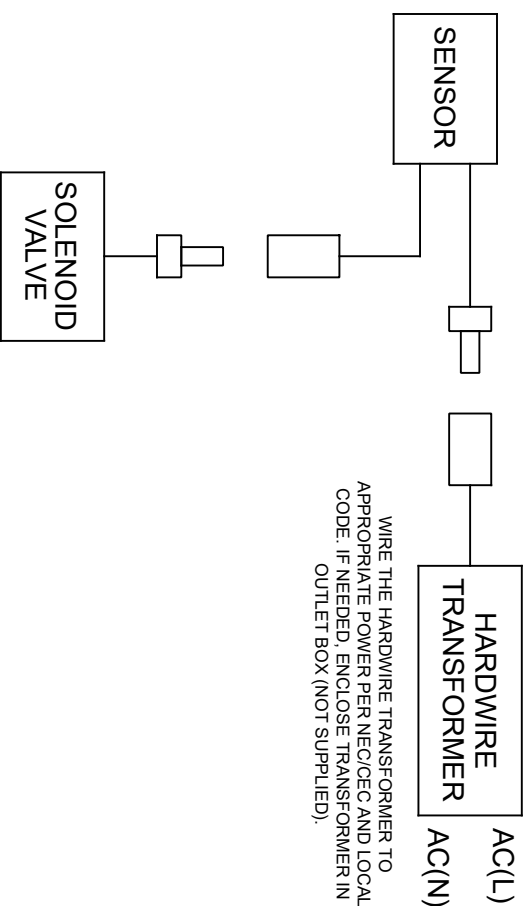

1RKHO.H CABLE WIRING SCHEMATIC

		<b>Haws</b>	
1459 KLEPPE LANE SPARKS, NEVADA, 89431 (775) 359-4712 FAX (775) 359-7424 E-MAIL: HAWS@HAWS.CO.COM WEBSITE: WWW.HAWS.CO.COM		MODEL(S) 1RKHO.P / 1RKHO.H SINGLE HANDS-OFF RETRO-FIT KIT	
ECN NO. REVISED PER BY:	5898	ECN: 5749	BJM
DRAWN:	BJM	DATE:	12/23/20
APPROVED:	BJM	CHK'D:	FV
SCALE:	N/A	DRAWING TYPE:	INSTALLATION
PART NUMBER	0580001133.D		
REVISION:	5		
SIZE:	A	SHEET:	4 OF 4