

FEATURES & BENEFITS

CONSTRUCTION

Barrier-free design with an 18-gauge Type 304 satin finished stainless steel swirl bowl assembly mounted on a 14-gauge Type 304 stainless steel wall bracket. Unit includes an in-wall mounting frame, and front panel access for P-trap and supply.

MOUNTING

Galvanized frame and 10 gauge surface plate provide the maximum mounting strength for the single bubbler drinking fountains.

BUBBLER HEAD

Polished chrome-plated brass bubbler head with integral laminar flow prevents splashing while providing a superior flow pattern. The integral 11/16" dia. basin shank and stainless anti-rotation roll pin for vandal resistance strength. Shielded, angled stream opening provides a steady source of drinking water at .45 gpm.

FOUNTAIN VALVE

Fountain incorporates a touchless sensor operated stainless steel solenoid valve controlled by a transformer for hands free operation. A pressure regulator is used to adjust the bubbler flow according to incoming water pressures.

VANDAL RESISTANT

The bubbler head, sensor, round bowl, drain strainer and bottom plate are locked in place, discouraging unwanted vandal tampering, and 30-second obstruction time-out to reduce tampering of sensor.

QUALITY CONTROL

Pre-built fountain is pressure tested to ensure no leaks and proper functionality.

OPTIONS

- Remote Drinking Fountain Water chiller: Model HCR8, 8 gph (30.3 L) remote water chiller provides instantaneous cooling to meet a continuous demand for chilled water.
- Bottle Filler: Model 1920HO, bottle filler can be a stand-alone station, or mounted above this fountain model.
- Back Panel: Model BP15, satin finish stainless steel 15 inch back panel for Model 1920HO.
- Bottle Filler Stand: Model BTL1001, add-on stainless steel stand to place bottle on when 1920HO bottle filler is used.

For more information, visit www.hawsc.com or call (888) 640-4297.



SPECIFICATIONS

Model 1001MSHO ADA wall mounted motion-activated vandal-resistant drinking fountain shall include an 18 gauge Type 304 Stainless Steel satin finish basin with integral swirl design, 14 gauge Type 304 Stainless Steel wall bracket, stainless steel satin finish back and access panels allowing for front access of P-trap and stop, in-wall mounting frame, 100% lead-free waterways, touchless sensor operated stainless steel solenoid valve with 30-second obstruction time-out controlled by a transformer, polished chrome-plated brass vandal-resistant bubbler head with integral laminar anti-squirt flow, chrome-plated brass vandal-resistant waste strainer, vandal-resistant bottom plate, and 1-1/4" O.D. (3.2cm) waste pipe.

REQUIRES MODEL MTGFR.DF1 PRICED SEPARATELY.

FOR INDOOR USE ONLY

APPLICATIONS

Perfect for either public or private indoor settings, the 1001MSHO is a great fit in areas where aesthetics are important to the overall appeal of the architecture. Beautiful satin finish helps to maintain the fountains overall appeal. Specifically, this type of wall mounted drinking fountain may be placed in settings such as: schools and other locations in and around office buildings. Model meets all current Federal Regulations for the disabled including those in the Americans with Disabilities Act. Haws manufactures drinking fountains, faucets and electric water coolers to be lead-free by all known definitions including NSF/ANSI/CAN 61- Section 9, NSF/ANSI/CAN 372, California Proposition 65, and the Federal Safe Drinking Water Act. Product is compliant to California Health and Safety Code 116875 (AB 1953-2006), and NSF/ANSI/CAN 61: Q ≤ 1.



NOTES:

1. HOLD ROUGH-IN DIMENSIONS $\pm 1/8"$ (3.2mm).
2. WHEN INSTALLING THIS UNIT, LOCAL, STATE, OR FEDERAL CODES SHOULD BE ADHERED TO FOR INSTALLATION DIMENSIONS (LOCATIONS), WASTE AND SUPPLY REQUIREMENTS OTHER THAN SHOWN.
3. INSTALLER MUST PROVIDE TRAP FOR PROPER INSTALLATION.
4. REFER TO 1RKHO.H OPERATION AND MAINTENANCE INSTRUCTIONS FOR TRANSFORMER AND SENSOR SETUP.

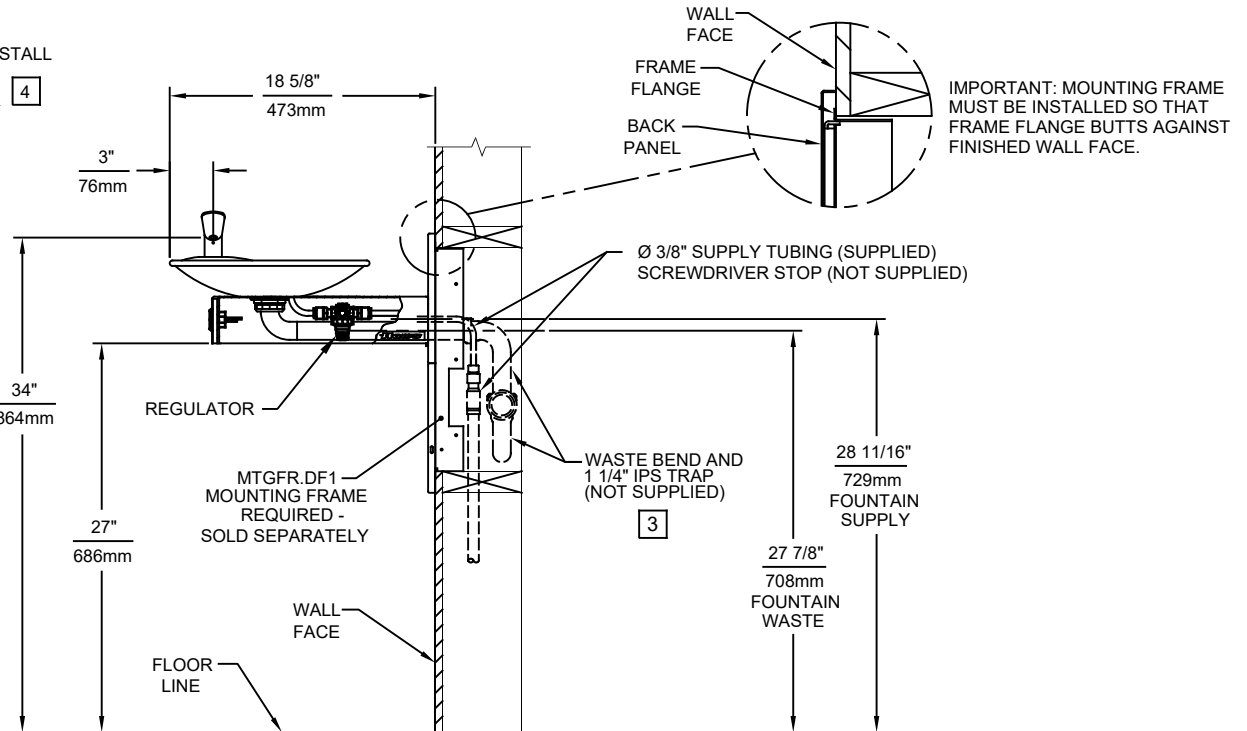
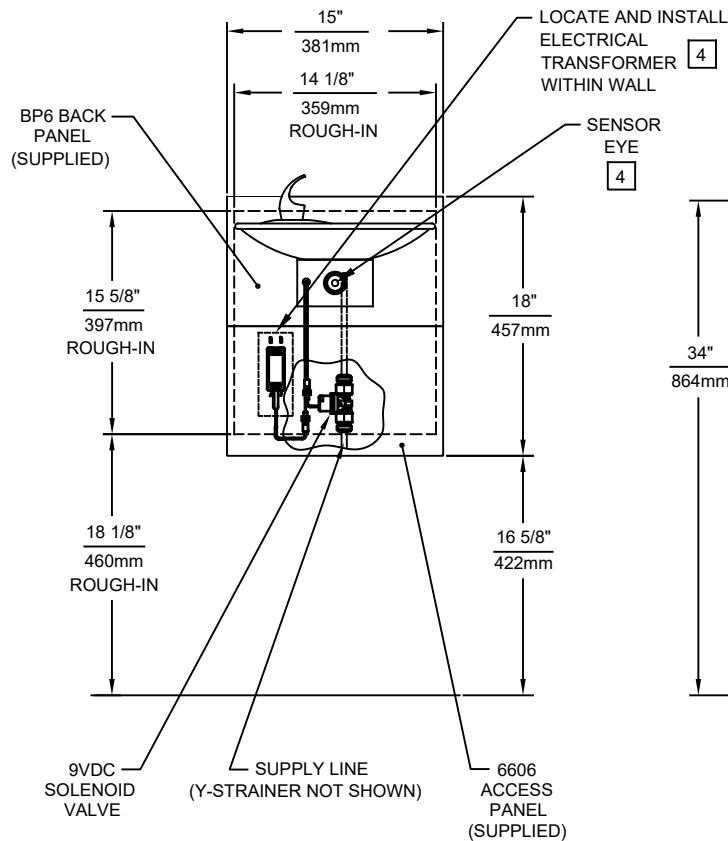
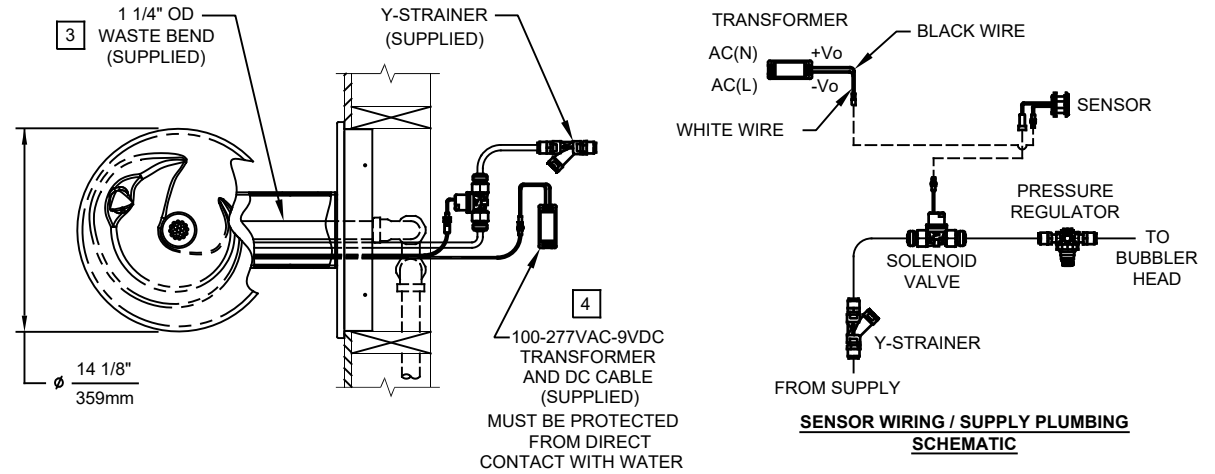

Haws

1455 KLEPPE LANE
SPARKS, NEVADA 89431
(775) 359-4712 FAX (775) 359-7424
E-MAIL: HAWS@HAWSCO.COM
WEBSITE: WWW.HAWSCO.COM

ECN NO.	REVISED PER	BY:	MODEL(S)	PART NUMBER
	ECN: 5733	FV		0510002021.D
DRAWN:	DATE:	CHKD.:	1001MSHO	REVISION
FV	09/28/21	BJM		1
APPROVED:	DATE:	SCALE:	DRAWING TYPE:	SIZE:
FV	09/30/21	1:14	INSTALLATION	A
				SHEET 1 OF 1