

INSTALLATION / RETRO FIT STEPS

**NOTE: FOR USE ON OTS UNITS ONLY, SUCH AS 8720, 8740 & 8770.**

1. WHEN REPLACING EXISTING EYEWASH ASSEMBLY WITH SP65LP FOLLOW STEPS 2 - 5. WHEN INSTALLING SP65LP ONTO NEW UNIT FOLLOW STEPS 3 THROUGH 5 (IF APPLICABLE).
- 2 REMOVE EXISTING EYEWASH BY ROTATING EYEWASH TEE COUNTER-CLOCKWISE. DO NOT REMOVE BRASS NIPPLE FROM BOWL HOLDER.
- 3 FASTEN SP65LP ONTO FITTING (NOT SUPPLIED). ORIENT TAB TOWARD REAR OF UNIT (AWAY FROM USER). DO NOT OVER TIGHTEN.
- 4 PLACE DUST COVER ONTO EYE/FACE WASH.
- 5 EXISTING COMPONENTS SHOWN (TYPICAL MODEL) ARE FOR REFERENCE ONLY AND MAY NOT REPRESENT SPECIFIC ASSEMBLY BEING INSTALLED/SERVED.

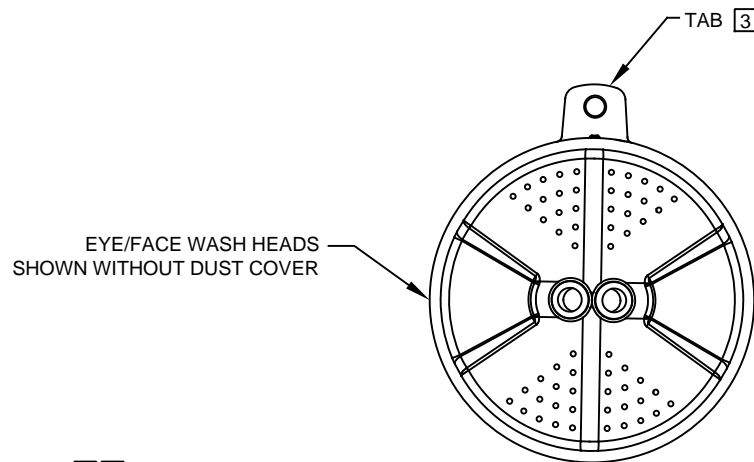

TOP VIEW

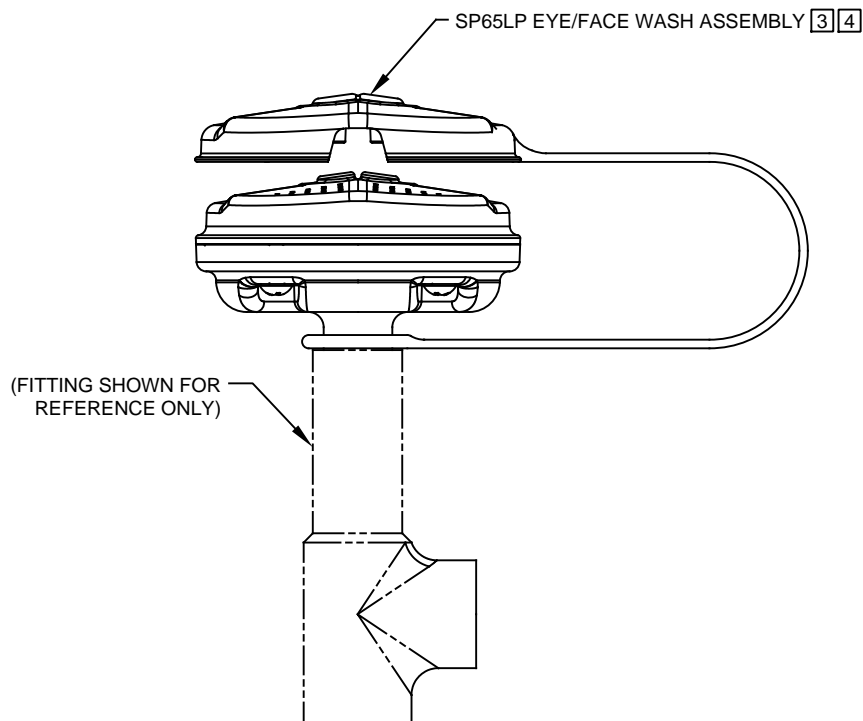

SIDE VIEW

		<b>Haws</b> <sup>®</sup>		1455 KLEPPE LANE SPARKS, NEVADA 89431 (775) 359-4712 FAX (775) 359-7424 E-MAIL: HAWS@HAWSO.COM WEBSITE: WWW.HAWSO.COM	
				ECN NO. 4109 DRAWN: VWC APPROVED: FV	REVISED PER: ECN: 5228 DATE: 10/27/17
		SCALE: NA	DRAWING TYPE: INSTALLATION	SIZE: A	SHEET 1 OF 2

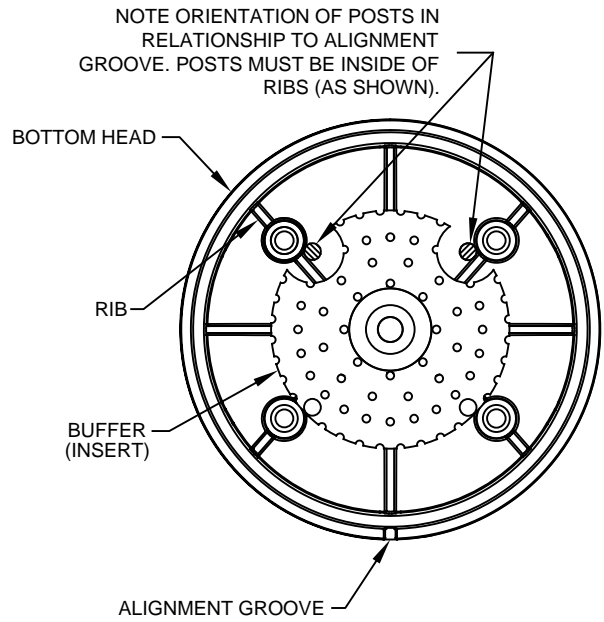
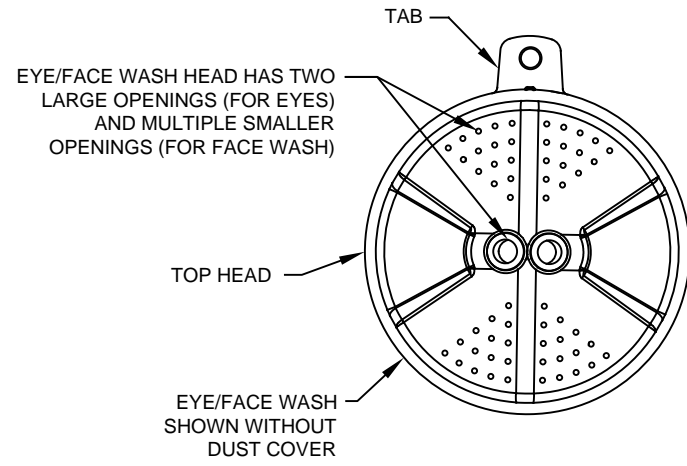
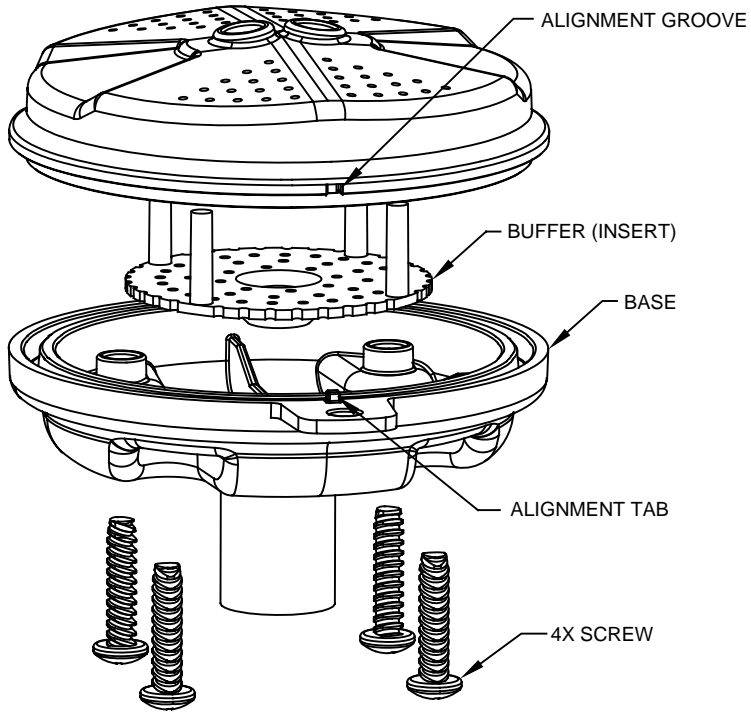

NOTE ORIENTATION OF POSTS IN RELATIONSHIP TO ALIGNMENT GROOVE. POSTS MUST BE INSIDE OF RIBS (AS SHOWN).



1455 KLEPPE LANE  
 SPARKS, NEVADA 89431  
 (775) 359-4712 FAX (775) 359-7424  
 E-MAIL: HAWS@HAWSO.COM  
 WEBSITE: WWW.HAWSO.COM

ECN NO. 4109	REVISED PER ECN: 5228	BY: VWC	MODEL(S)	PART NUMBER
DRAWN: VWC	DATE: 10/27/17	CHKD: VWC	SP65LP	0110000661
APPROVED: FV	DATE: 11/08/17		AXION EYE/FACE WASH	REVISION 1
			SCALE: NA	DRAWING TYPE: INSTALLATION
			SIZE: A	SHEET 2 OF 2