

ITEM	DESCRIPTION	PART NO.
1	BACK PANEL P/N	0004023590
2	SMALL BACK PANEL P/N	0004023587
3	GRILLE 1117L P/N	0002626600
** 4	MOUNTING FRAME	MTGFR.17
5	BUTTON	PBA6
6	VALVE	5874PBF
7	BUBBLER HEAD	5703M
8	STRAINER ASSY	6462
9	TRAP	0005982900
** 10	CHILLER, REMOTE	HCR8
11	SPANNER WRENCH	0006983506
12	BOTTOM PLATE	0004449315
13	KEY HEX F/PINNED HEX	0002981127
14	VALVE REPAIR KIT	VRK5874

** REQUIRED - SOLD SEPARATELY

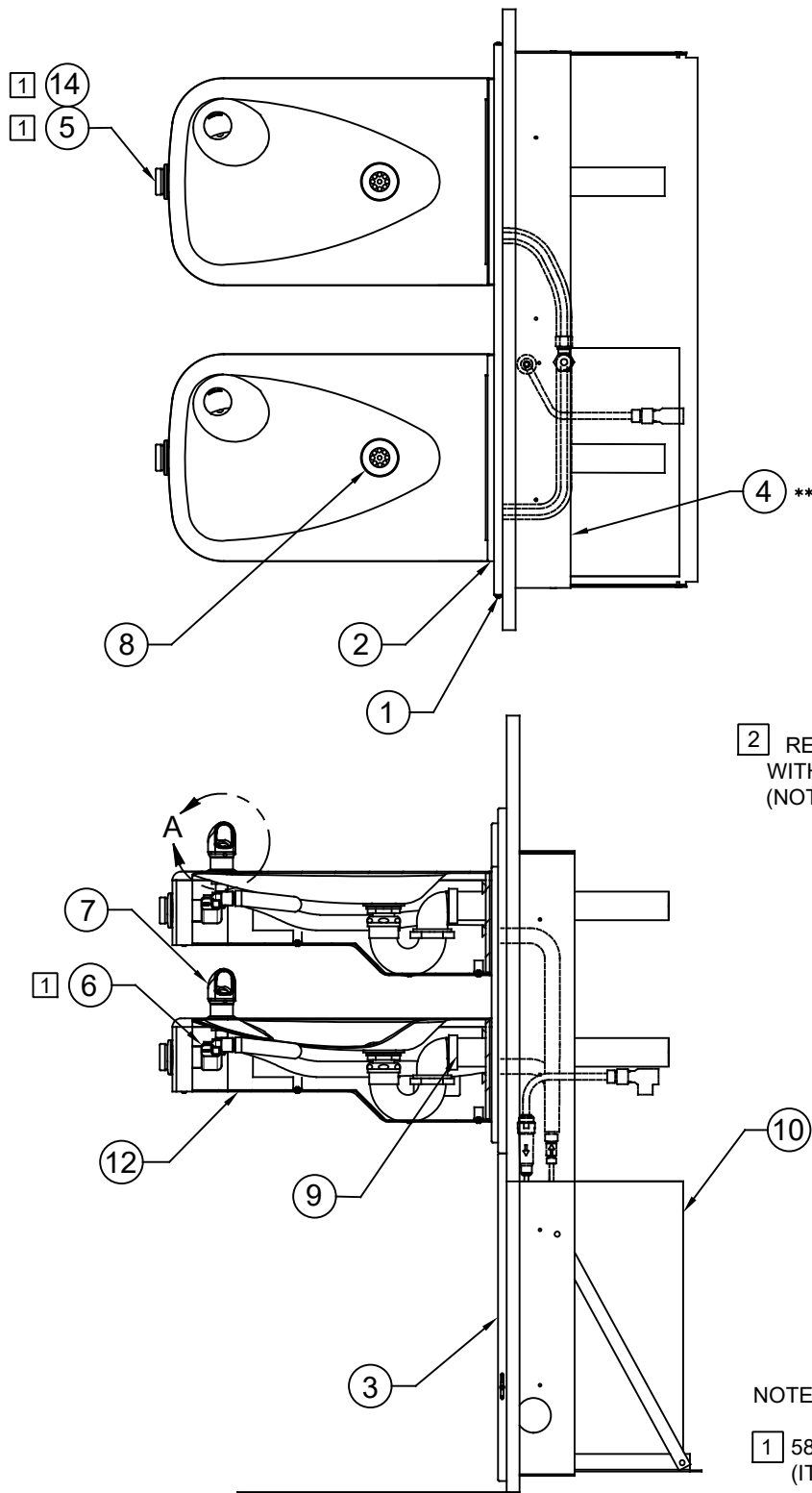

2 REMOVE INSERT WITH 5/16 HEX SOCKET (NOT SUPPLIED)

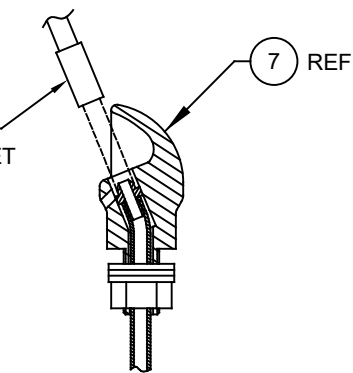

DETAIL A
ROTATED 90° INTO VIEW

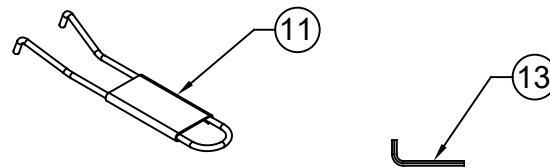

NOTES:

- 1 5874PBF (ITEM 6) INCLUDES VRK5874 CARTRIDGE ASSEMBLY (ITEM 14) AND PBA6 FLANGED PUSH BUTTON (ITEM 5).
- 2 ENSURE TUBE IS DISCONNECTED FROM PUSH BUTTON VALVE BODY PRIOR TO REMOVAL. APPLY ONE DROP OF LOCTITE 222MS TO NOZZLE THREADS PRIOR TO FASTENING BACK ONTO BUBBLER HEAD. RE-ATTACH TUBE TO VALVE.

PARTS BREAKDOWN

WHEN ORDERING PARTS PLEASE SPECIFY MODEL NUMBER.

		1455 KLEPPE LANE SPARKS, NEVADA 89431 (775) 359-4712 FAX (775) 359-7424 E-MAIL: HAWS@HAWS.CO.COM WEBSITE: WWW.HAWS.CO.COM	
		ECN NO. REVISED PER BY ECN: 5893 FV	MODEL(S) H1117.8
DRAWN DATE C.FENNER 10-25-06	CHECKED KM	REVISION 13	
APPROVED DATE FV 09/06/23	SCALE: N/A	DRAWING TYPE: PARTS BREAKDOWN	SIZE: A SHEET 1 OF 1