

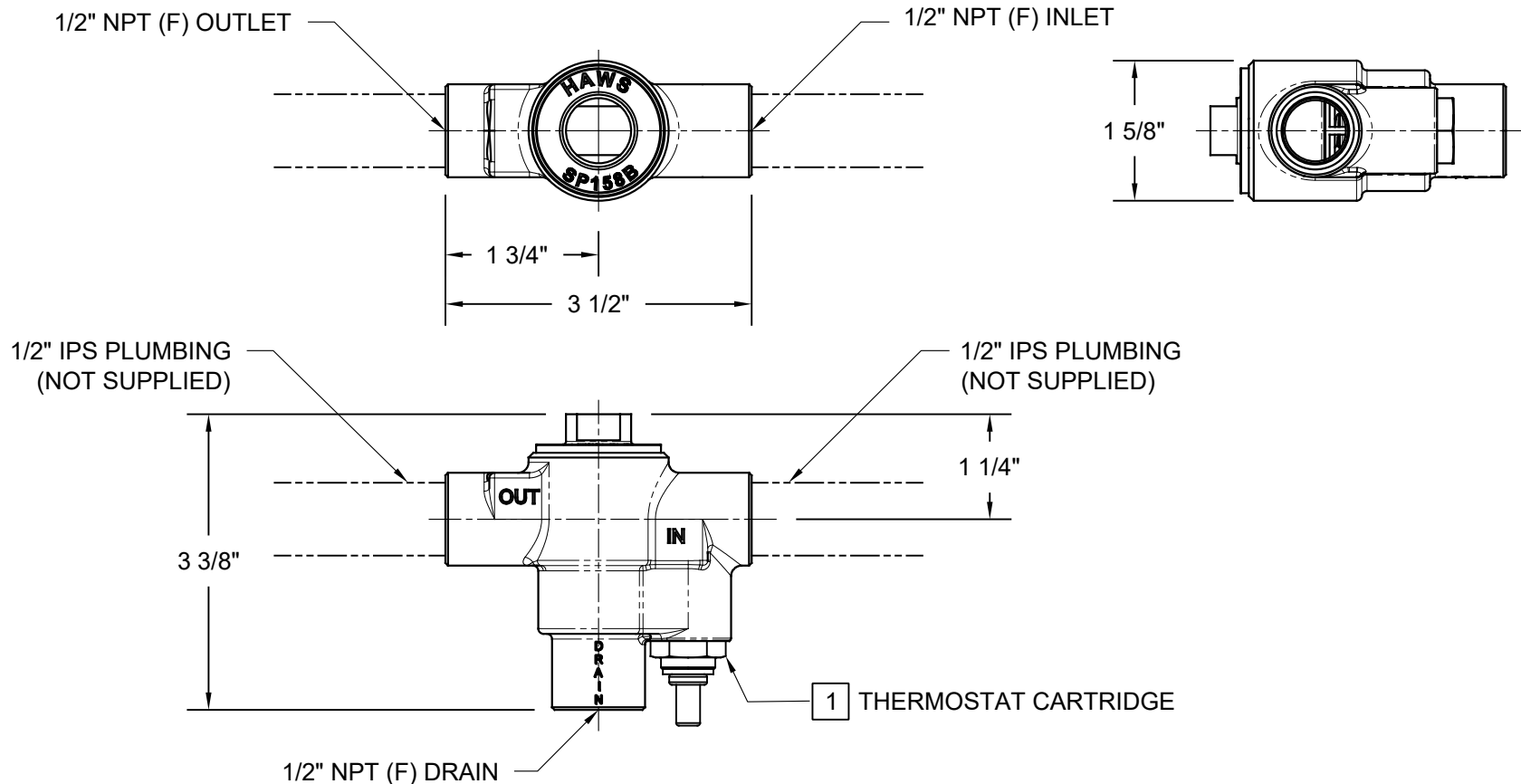

NOTES:

- 1 THERMOSTAT CARTRIDGE REPLACEMENT INFO: CONTACT HAWS TECHNICAL SUPPORT AT TELEPHONE NUMBER LISTED BELOW. REPLACEMENT PART IS - MODEL VRK158B (KIT, REPAIR, SP158B).



IN-LINE DRAIN INSTALLATION SHOWN  
(INLET AND OUTLET CONNECTED)

FOR SPECIFIC INSTRUCTION REGARDING INSTALLATION, RETRO-FIT, MAINTENANCE OF THIS MODEL CONTACT HAWS TECHNICAL SUPPORT AT 1-800-766-5612.

		1455 KLEPPE LANE SPARKS, NEVADA 89431 (775) 359-4712 FAX (775) 359-7424 E-MAIL: HAWS@HAWS.CO.COM WEBSITE: WWW.HAWS.CO.COM	
		ECN NO. 4703 REVISED PER VWC DATE 10/25/12 APPROVED: NE	BY: DP DATE: 10/25/12 CHK'D: FV DATE: 10/07/19
SCALE: 1/1		DRAWING TYPE: INSTALLATION	SIZE: A SHEET 1 OF 2

1/2" NPT (F) OUTLET

1/2" NPT (F) INLET

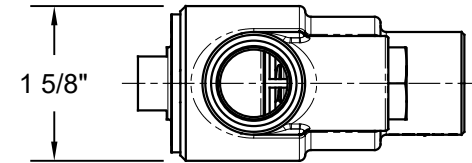
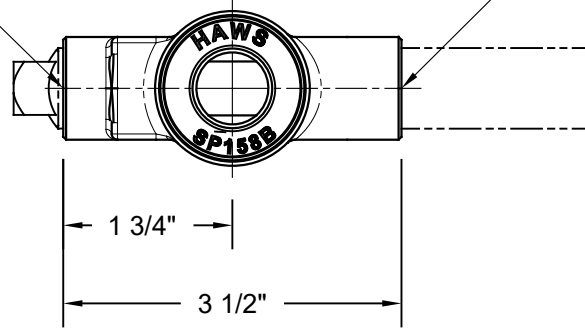

1/2" NPT (M) SQUARE PLUG  
(NOT SUPPLIED)

1/2" IPS PLUMBING  
(NOT SUPPLIED)

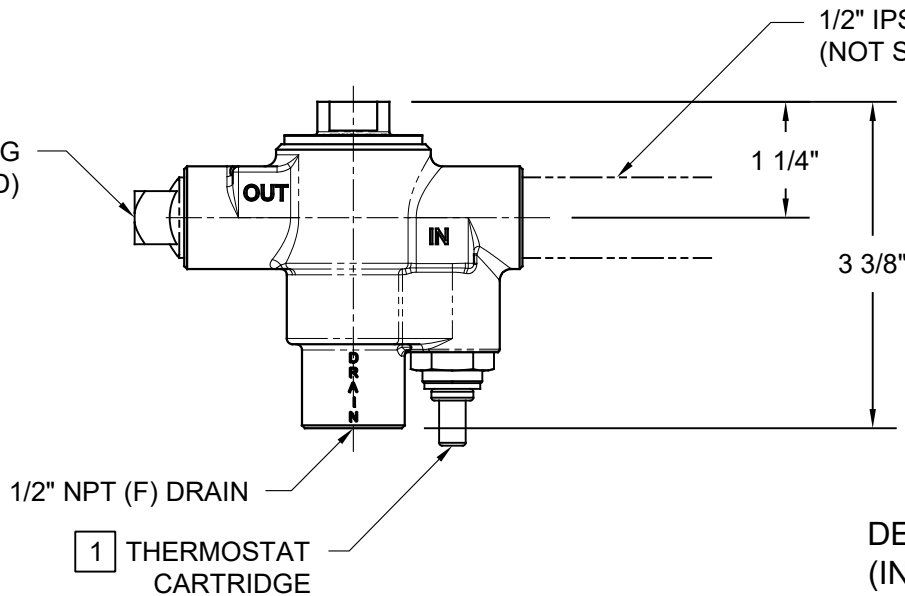

DEAD-LEG DRAIN INSTALLATION SHOWN  
(INLET CONNECTED / OUTLET PLUGGED)

FOR SPECIFIC INSTRUCTION REGARDING INSTALLATION,  
RETRO-FIT, AND MAINTENANCE OF THIS MODEL CONTACT  
HAWES TECHNICAL SUPPORT AT 1-800-766-5612.

		1455 KLEPPE LANE SPARKS, NEVADA 89431 (775) 359-4712 FAX (775) 359-7424 E-MAIL: HAWES@HAWSCO.COM WEBSITE: WWW.HAWSCO.COM	
		ECN NO. 4703 DRAWN: VWC APPROVED: NE	REVISED PER: ECN: 5481 DATE: 10/25/12 DATE: 10/07/19
SCALE: 1/1		DRAWING TYPE: INSTALLATION	
SIZE: A		SHEET 2 OF 2	