

NOTES:

1. DIMENSIONAL TOLERANCES: $\pm 1/2"$.
2. RECOMMENDED WATER PRESSURE:
55 psi (3.79 bar) MIN.
90 psi (6.21 bar) MAX.
3. **MODEL 9400:**
RECOMMENDED SATURATED STEAM PRESSURE:
45 psi TO 60 psi (3.10 bar TO 4.14 bar)
MAXIMUM SATURATED STEAM TEMPERATURE:
350° F (177° C)
4. **MODEL 9400LPS:**
RECOMMENDED SATURATED STEAM PRESSURE:
15 psi TO 30 psi (1.03 bar TO 2.07 BAR)
MAXIMUM SATURATED STEAM PRESSURE:
274° F (134° C) @ 30 psi (2.07 bar)
250° F (121° C) @ 15 psi (1.03 bar)

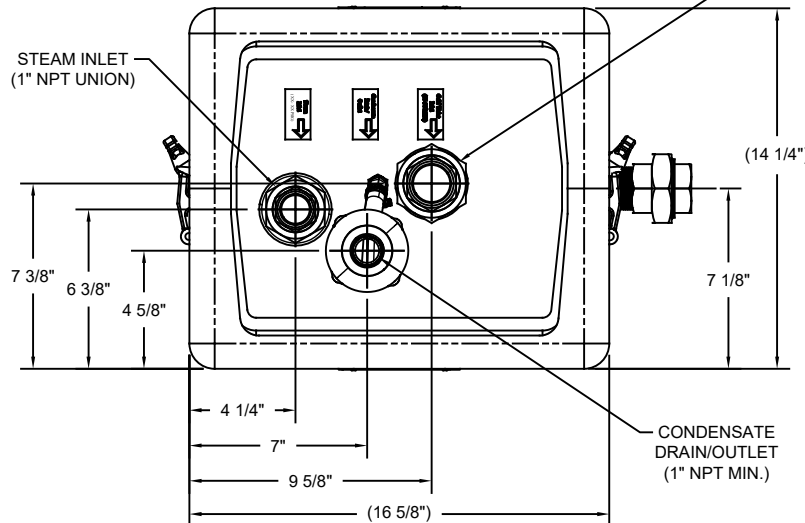

MODEL 9400
SHOWN

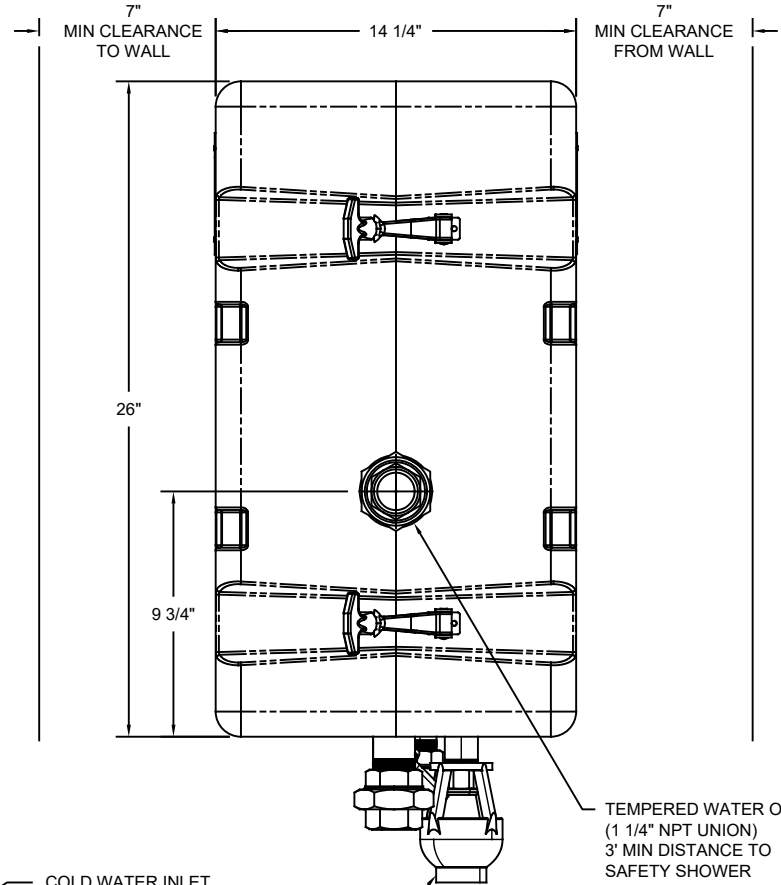
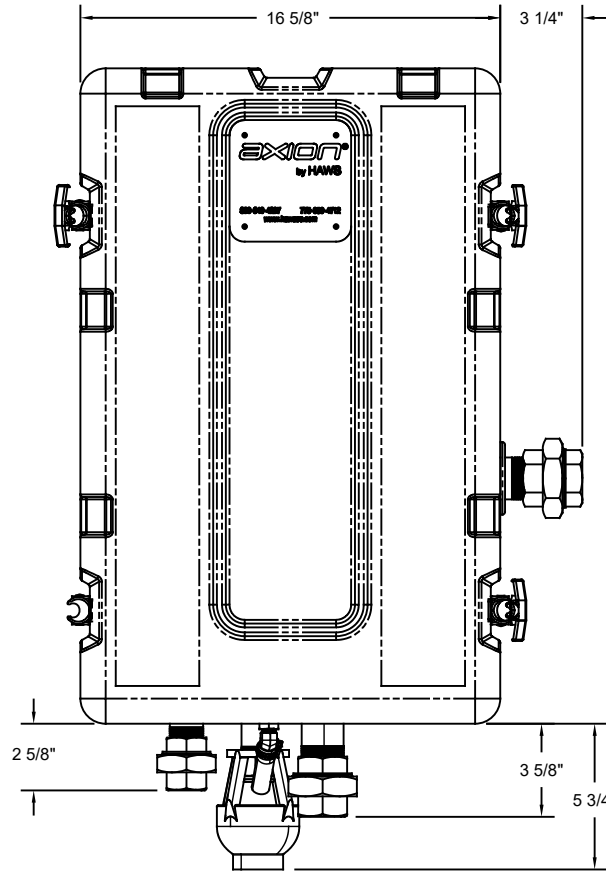

COLD WATER INLET
(1 1/4" NPT UNION)

DRAIN LINE WITH
AIR GAP FITTING
(1" NPT MIN.)

TEMPERED WATER OUTLET
(1 1/4" NPT UNION)
3' MIN DISTANCE TO
SAFETY SHOWER



1455 KLEPPE LANE
SPARKS, NEVADA 89431
(775) 359-4712 FAX (775) 359-7424
E-MAIL: HAWS@HAWSCO.COM
WEBSITE: WWW.HAWSCO.COM

ECN NO. 4930	REVISED PER VC	BY: FV	MODEL(S)	PART NUMBER
DATE: 10/01/14	CHKD.: BJM		9400/9400LPS	0002080243.D
APPROVED: FV	DATE: 11/12/21	SCALE: NA	DRAWING TYPE: INSTALLATION	REVISION 11
			SIZE: A	SHEET 1 OF 1