

**NOTES:**

1. AUDIBLE AND VISIBLE ALARM ACTIVATED WHEN SHOWER OR EYEWASH IS IN USE.
2. ALL ELECTRICAL COMPONENTS UL CERTIFIED. 120VAC SUPPLY VOLTAGE REQUIRED, APPROXIMATELY 100VA ALL ELECTRICAL HOOKUPS TO MAIN JUNCTION BOX.
3. SUITABLE FOR CLASS I, DIV. 1 GROUPS C, D TEMPERATURE RATING T4 (135°C) LOCATION.
4. LIGHT MUST BE ORIENTED IN A VERTICAL POSITION AS SHOWN IN ORDER TO MEET NEMA 4 RATING.
5. INSTALLER MUST USE THREAD SEALANT, SUCH AS APPLETON TLC3, RECOMMENDED FOR USE IN HAZARDOUS LOCATIONS ON ALL ELECTRICAL NPT CONNECTIONS.

SEE MOUNTING SYSTEM DETAIL

MAIN JUNCTION BOX (120 VAC INCOMING POWER NOT SUPPLIED) CONDUIT ENTRY FOR CUSTOMER ELECTRICAL HOOKUP ON TOP SEE SHEET 2 FOR ELECTRICAL WIRING DIAGRAM

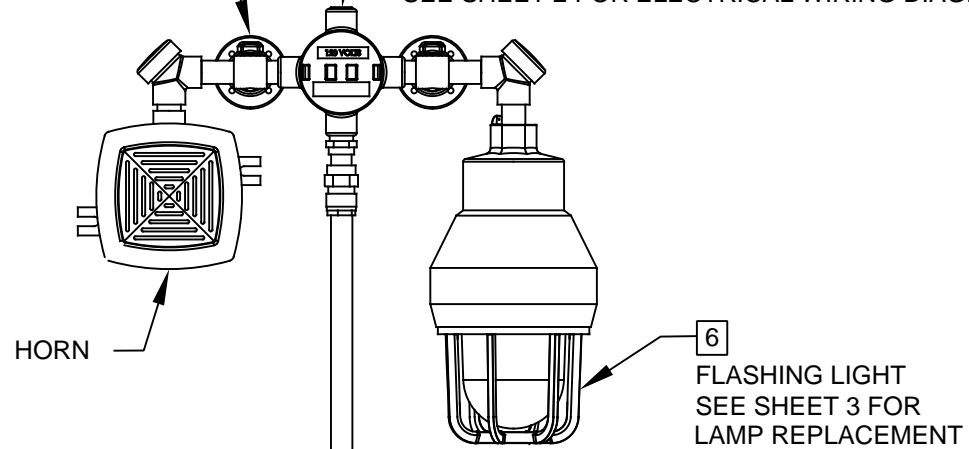

ARMORED CABLE; MINIMUM BEND RADIUS 5"; DO NOT CUT OR MODIFY.

FLOW SWITCH

**CAUTION:**  
DO NOT DISASSEMBLE OR ROTATE THIS ASSEMBLY AT ANY JOINT AS DAMAGE WILL OCCUR

1-1/4" IPS WATER SUPPLY

NOTE FLOW DIRECTION ARROW

1-1/4" UNIONS (RECOMMENDED NOT SUPPLIED)

6" MIN. 152mm STRAIGHT

6" MIN. 152mm STRAIGHT

SHOWER

2X 3/4" NIPPLE

2X 1-1/4" PIPE CLAMP (MAX PIPE SIZE Ø1 7/8")

2X WALL MOUNT FLANGE MOUNTING HARDWARE NOT SUPPLIED. SEE MOUNTING HOLE PATTERN BELOW

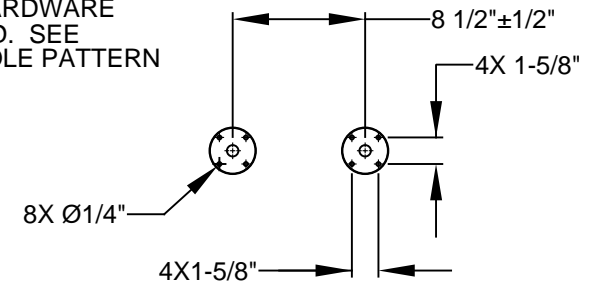

**MOUNTING SYSTEM DETAIL (FOR PIPE OR WALL MOUNT)**

**SWITCH MUST BE MOUNTED IN HORIZONTAL POSITION**



1455 KLEPPE LANE  
SPARKS, NEVADA 89431  
(775) 359-4712 FAX (775) 359-7424  
E-MAIL: HAWS@HAWSCO.COM  
WEBSITE: WWW.HAWSCO.COM

ECN NO. 4140	REVISED PER ECN: 5197	BY: GC	MODEL(S)	PART NUMBER
DRAWN: SLS	DATE: 07/08	CHKD.:	9001EXPC1D1 ALARM	0002077071.D
APPROVED: FV	DATE: 09/25/17	SCALE: 1:1	DRAWING TYPE: INSTALLATION	DRAWING NO. 15361A00
				REV 11
				SHEET 1 OF 3

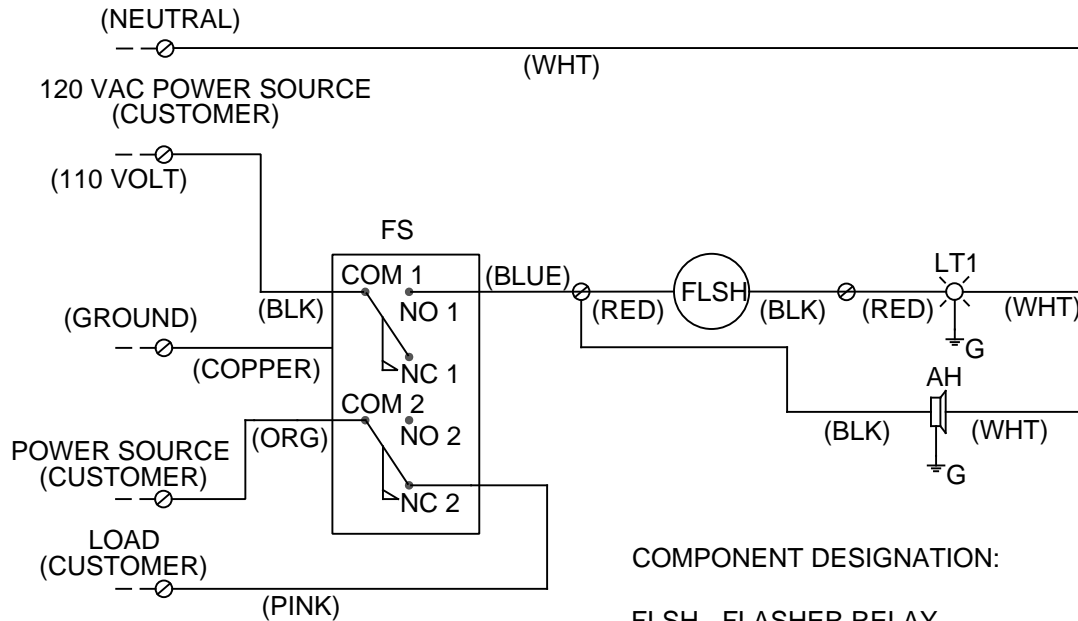

COMPONENT DESIGNATION:

- FLSH - FLASHER RELAY
- LT1 - RED LIGHT
- FS - FLOW SWITCH
- AH - ALARM HORN

**ELECTRICAL WIRING DIAGRAM**

		<b>Haws</b> <sup>®</sup>		1455 KLEPPE LANE SPARKS, NEVADA 89431 (775) 359-4712 FAX (755) 359-7424 E-MAIL: HAWS@HAWS.CO.COM WEBSITE: WWW.HAWS.CO.COM	
				ECN NO. 4140 DRAWN: SLS APPROVED: FV	REVISED PER: ECN: 5197 DATE: 07/08 DATE: 09/25/17
SCALE: 1:1		DRAWING TYPE: INSTALLATION		SIZE: A SHEET 2 OF 3	

NOTES: (CONTINUED FROM SHEET 1)

6 LIGHT REPLACEMENT INSTRUCTIONS:

- 1) REMOVE GUARD/GLOBE ASSEMBLY:  
FIRST LOOSEN SET SCREW (LOCATED ON GUARD WHERE SHOWN). NEXT, ROTATE ASSEMBLY COUNTER CLOCKWISE UNTIL GUARD IS FREE FROM PENDANT MOUNT AND LAMP IS EXPOSED.
- 2) ONLY REPLACE LAMP WITH HAWS P/N 0003225505.  
**WARNING - EXPLOSION HAZARD - SUBSTITUTION OF COMPONENTS MAY IMPAIR SUITABILITY FOR CLASS 1, DIVISION 1.**
- 3) REPLACE GUARD/GLOBE ASSEMBLY:  
ROTATE ASSEMBLY CLOCKWISE ONTO THE PENDANT MOUNT UNTIL TIGHT AND TIGHTEN SET SCREW.

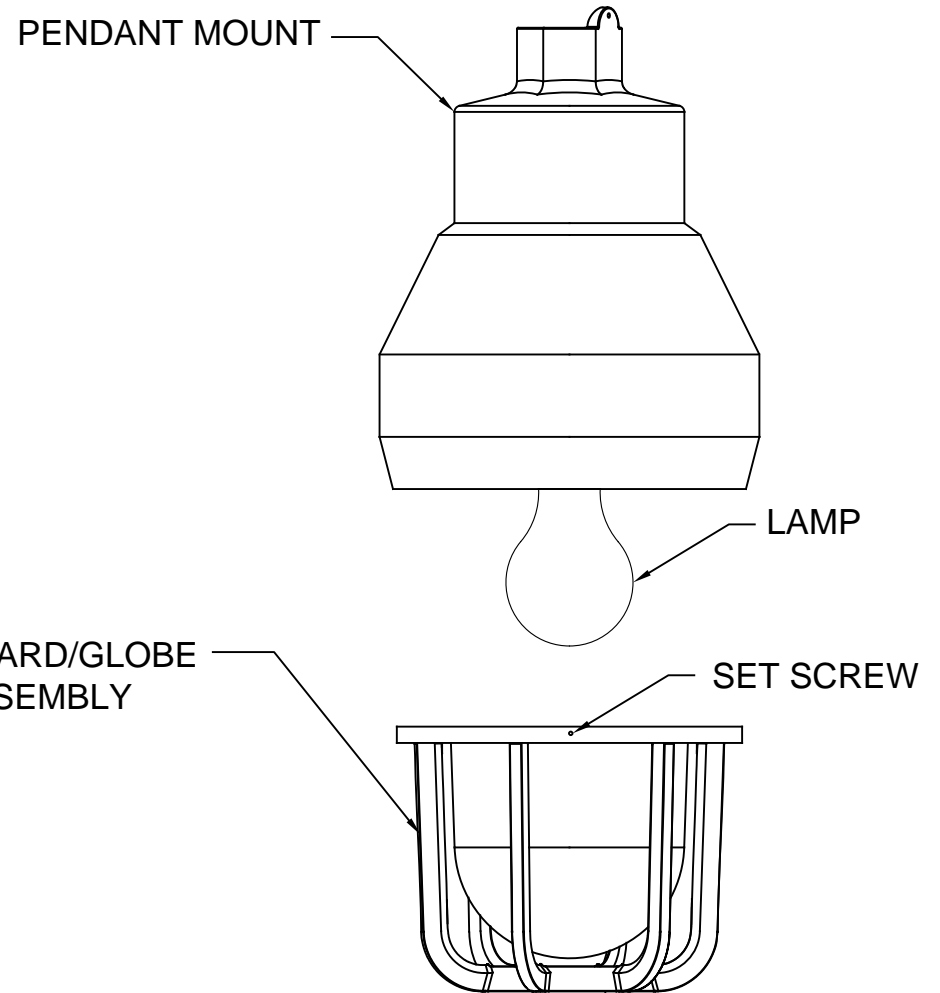

		<b>Haws</b> <sup>®</sup>		1455 KLEPPE LANE SPARKS, NEVADA 89431 (775) 359-4712 FAX (755) 359-7424 E-MAIL: HAWS@HAWS.CO.COM WEBSITE: WWW.HAWS.CO.COM	
				ECN NO. 4140 DRAWN: SLS APPROVED: FV	REVISED PER: ECN: 5197 DATE: 07/08 DATE: 09/25/17
SCALE: 1:1		DRAWING TYPE: INSTALLATION		SIZE: A SHEET 3 OF 3	