

NOTES:

1. WHEN INSTALLING THIS UNIT, LOCAL, STATE, OR FEDERAL CODES SHOULD BE ADHERED TO FOR INSTALLATION DIMENSIONS (LOCATIONS), WASTE AND SUPPLY REQUIREMENTS OTHER THAN SHOWN.
2. TO COMPLY WITH ANSI Z358.1-2014 FOR EMERGENCY EYEWASH OR EYE/FACE WASH: EYEWASH OR EYE/FACE WASH SHALL BE POSITIONED SUCH THAT FLUSHING FLUID PATTERN IS NOT LESS THAN 33" (838mm) AND NO GREATER THAN 53" (1346mm) FROM SURFACE ON WHICH USER STANDS; AND 6.0" (153mm) MINIMUM FROM WALL OR NEAREST OBSTRUCTION.
3. DO NOT USE REGULAR PIPE SEALANT. IF NECESSARY USE DOW CORNING 832 SEALANT PLACING FIVE SMALL BEADS ON MALE THREADS, JUST ABOVE THE FIRST THREAD.
4. DIMENSIONS MAY VARY BY ±1/2" (13 mm).

(NOTES CONTINUED ON SHEET 2.)

		1455 KLEPPE LANE SPARKS, NEVADA 89431 (775) 359-4712 FAX (775) 359-7424 E-MAIL: HAWS@HAWSCO.COM WEBSITE: WWW.HAWSCO.COM	
		ECN NO. 4632 DRAWN: RTM APPROVED: FV	REVISED PER: FV DATE: 3/29/05 DATE: 02/08/22
SCALE: NA		DRAWING TYPE: INSTALLATION	SIZE: A SHEET 1 OF 4

NOTES: (CONTINUED FROM SHEET 1 OF 4)

4. FREEZE PROTECTION VALVE INSTALLATION INSTRUCTIONS:

- A** INSTALL VALVE SUB-ASSEMBLY INTO FEMALE SECTION OF UNION AND TIGHTEN WATER-TIGHT.
- B** FORM HEAT TRACE CABLE AROUND VALVE AND PLUG, APPLY 2X CABLE-TIES TO HEAT TRACE CABLE, AS SHOWN, ENSURING THAT HEAT TRACE CABLE IS PRESSED FIRMLY AGAINST SIDES OF VALVE (PUSH ANY LOOSE HEAT TRACE CABLE BACK INSIDE JACKET THROUGH RUBBER GROMMET). TRIM EXCESS CABLE-TIE STRAPPING.
- C** SLIDE INNER TUBE W/ PLUGGED END OVER VALVE WITH ADHESIVE SEAM FACING BOTTOM AND NON-PLUGGED END OF TUBE BUTTED UP AGAINST UNION SURFACE. REMOVE 2X ADHESIVE TAPE FROM SEAM AND SQUEEZE ADHESIVE SEAMS TOGETHER AROUND VALVE. APPLY 2X CABLE-TIES TO TUBE, IN APPROXIMATE LOCATIONS SHOWN. TRIM EXCESS CABLE-TIE STRAPPING.

(NOTES CONTINUED ON SHEET 3 OF 4)

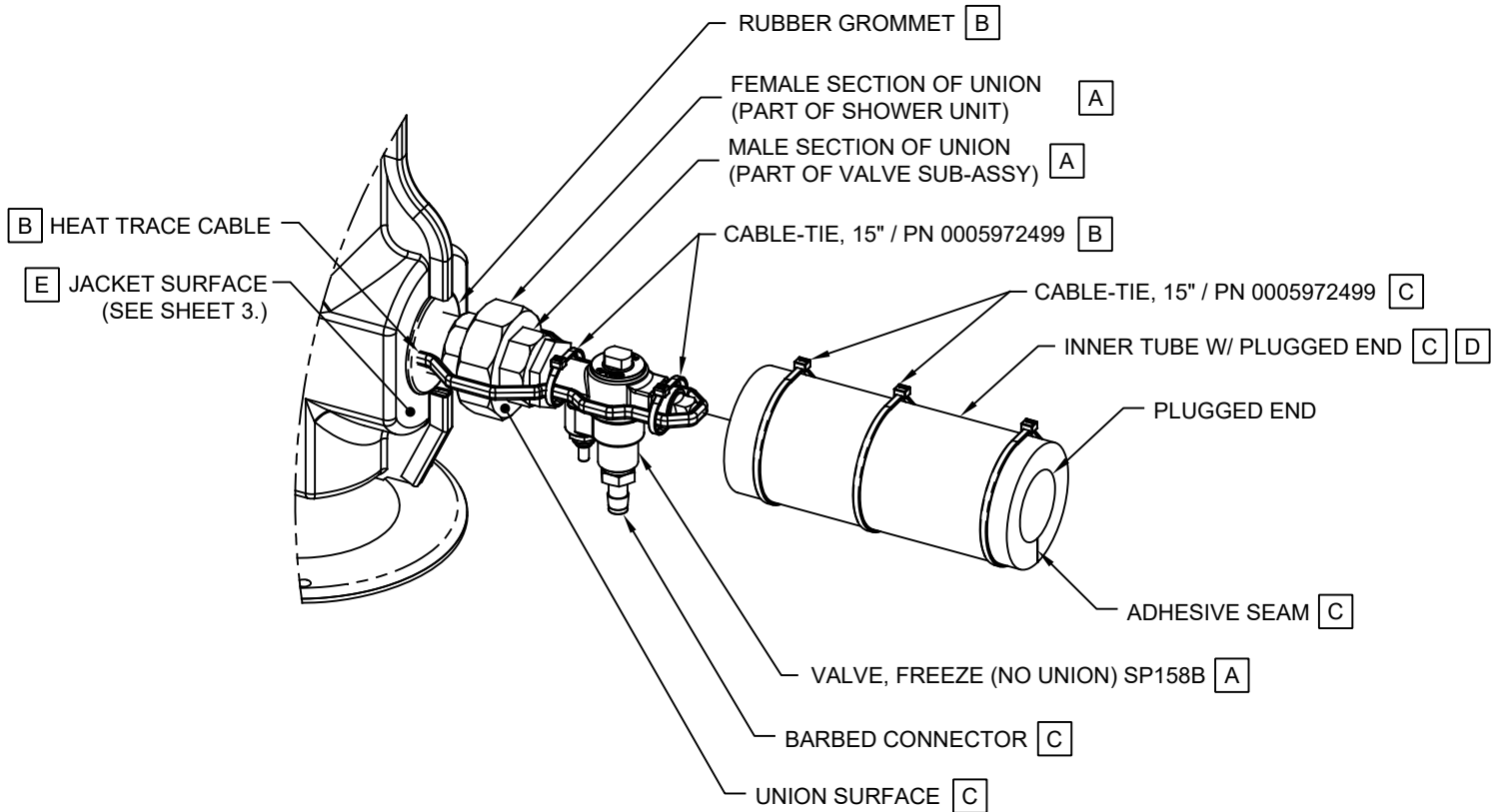

SP158B VALVE SHOWN CONNECTED TO BOTTOM UNION FOR REFERENCE ONLY. VALVE CAN BE INSTALLED AT TOP OR BOTTOM.

		1455 KLEPPE LANE SPARKS, NEVADA 89431 (775) 359-4712 FAX (775) 359-7424 E-MAIL: HAWS@HAWSCO.COM WEBSITE: WWW.HAWSCO.COM	
		ECN NO. 4632 DRAWN: VWC APPROVED: FV	REVISED PER BY: ECN: 5762 FV DATE: 12/2/12 DATE: 02/08/22
SCALE: NA		DRAWING TYPE: INSTALLATION	SIZE: A SHEET 2 OF 4

NOTES: (CONTINUED FROM SHEET 2 OF 4)

5. FREEZE PROTECTION VALVE INSTALLATION INSTRUCTIONS (CONTINUED):

D WRAP OUTER TUBE OVER INNER TUBE ENCAPSULATED VALVE WITH ADHESIVE SEAM ORIENTED PERPENDICULAR TO SEAM OF INNER TUBE. PUSH OUTER TUBE UP AGAINST JACKET SURFACE. WHEN TUBE IS MOUNTED FIRMLY AGAINST JACKET SURFACE, SQUEEZE TUBE AT BARBED CONNECTOR SUCH THAT BARBED NIPPLE PUSHES THROUGH OUTER TUBE WALL. (PUSHING CONNECTOR THROUGH WALL WILL EXTRUDE A CYLINDRICAL PLUG OF TUBING TO BREAK FREE. DISCARD PLUG.) PUSH TUBE DOWN EVEN FURTHER SO THAT HOLE IN TUBE STRETCHES AROUND HEXAGONAL BOSS OF CONNECTOR. SQUEEZE OUTER TUBE TIGHT UNTIL ADHESIVE SEAMS ARE CLOSE ENOUGH TO SEAL. REMOVE PROTECTIVE TAPE AND SEAL SEAMS.

E TO ENSURE PROPER INSULATION OF UNION; THERE MUST BE NO SPACE BETWEEN OUTER TUBE AND JACKET SURFACE (SEE SHEET 2 FOR SURFACE CALLOUT). THEREFORE, SLICE TWO PLACES, TOP SIDE AND BOTTOM SIDE, COMPLETELY THROUGH OUTER TUBE TO A LENGTH EQUAL TO DEPTH OF TRIM SEAL. FORCE SLICED TUBE AROUND TRIM SEAL AND PUSH TUBE TIGHTLY AGAINST JACKET, AS SHOWN. APPLY 2X CABLE-TIE HEAD, AND 2X CABLE-TIE STRAP, TO TUBE, IN APPROXIMATE LOCATIONS SHOWN. TRIM EXCESS STRAPPING.

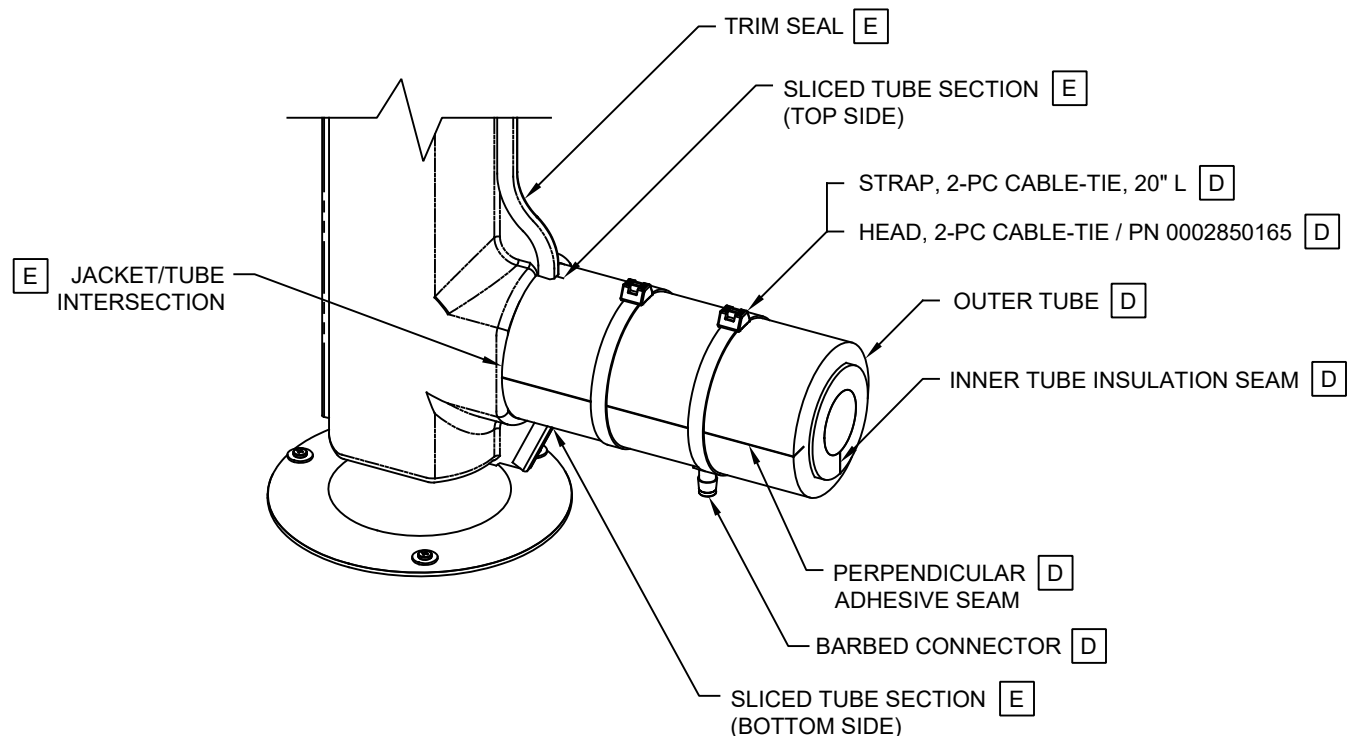

SP158B VALVE SHOWN CONNECTED TO BOTTOM UNION FOR REFERENCE ONLY. VALVE CAN BE INSTALLED AT TOP OR BOTTOM.

		Haws [®]		1455 KLEPPE LANE SPARKS, NEVADA 89431 (775) 359-4712 FAX (775) 359-7424 E-MAIL: HAWS@HAWS.CO.COM WEBSITE: WWW.HAWS.CO.COM	
				ECN NO. 4632 DRAWN: VWC APPROVED: FV	REVISED PER BY: ECN: 5762 DATE: 12/2/12 DATE: 02/08/22
SCALE: NA		DRAWING TYPE: INSTALLATION		SIZE: A	SHEET 3 OF 4

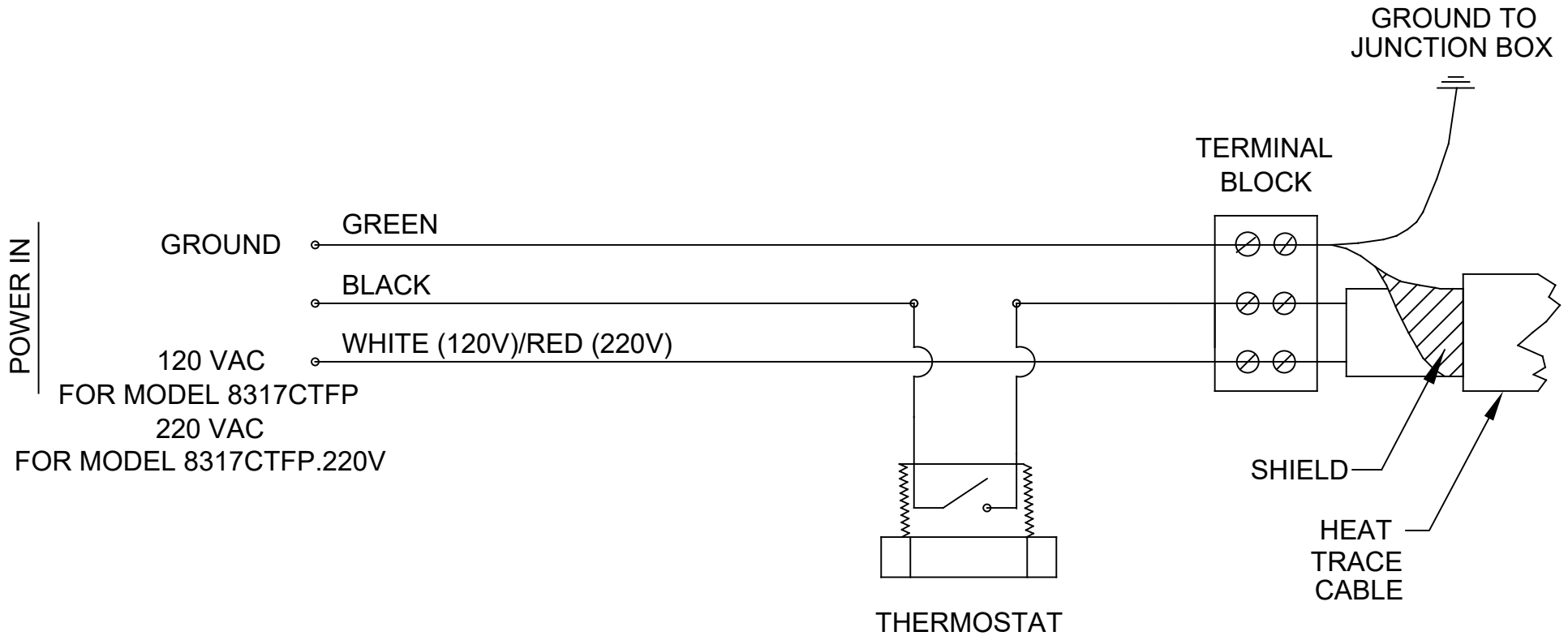

ELECTRICAL SCHEMATIC

		Haws [®]		1455 KLEPPE LANE SPARKS, NEVADA 89431 (775) 359-4712 FAX (775) 359-7424 E-MAIL: HAWS@HAWS.CO.COM WEBSITE: WWW.HAWS.CO.COM	
				MODEL(S) 8317CTFP (120V) / 8317CTFP.220V	
ECN NO. 4632	REVISED PER ECN: 5762	BY: FV	DRAWN: RTM		DATE: 3/29/05
APPROVED: FV		DATE: 02/08/22	CHKD.: BJM		REVISION 19
SCALE: NA		DRAWING TYPE:		INSTALLATION	
SIZE: A		SHEET 4 OF 4			