

SEE SHEET 2 FOR TOP VIEW

NOTES:

1. WHEN INSTALLING THIS UNIT, LOCAL, STATE, OR FEDERAL CODES SHOULD BE ADHERED TO FOR INSTALLATION DIMENSIONS (LOCATIONS), WASTE AND SUPPLY REQUIREMENTS OTHER THAN SHOWN.
2. TO COMPLY WITH ANSI Z358.1-2014 FOR EMERGENCY SHOWER EQUIPMENT:
 - SHOWER SHALL BE POSITIONED SUCH THAT SHOWER HEAD IS NO LESS THAN 82" (2083mm) AND NO GREATER THAN 96" (2438mm) FROM SURFACE ON WHICH USER STANDS.
 - SHOWER SPRAY PATTERN SHALL HAVE A MINIMUM DIAMETER OF 20" (508mm) AT 60" (1524mm) ABOVE SURFACE ON WHICH USER STANDS, AND CENTER OF SPRAY PATTERN SHALL BE LOCATED NO LESS THAN 16" (406mm) FROM NEAREST OBSTRUCTION.
3. DIMENSIONS MAY VARY BY ±1/2" (13 mm).

		Haws [®]		1455 KLEPPE LANE SPARKS, NEVADA 89431 (775) 359-4712 FAX (775) 359-7424 E-MAIL: HAWS@HAWS.CO.COM WEBSITE: WWW.HAWS.CO.COM	
				ECN NO. REVISED PER BY: ECN: 5925 FV	MODEL(S)
DRAWN: DO	DATE: 5/98	CHK'D: JC	8163	REVISION	9
APPROVED: FV	DATE: 05/31/23	SCALE: NA	DRAWING TYPE: INSTALLATION	SIZE: A	SHEET 1 OF 2

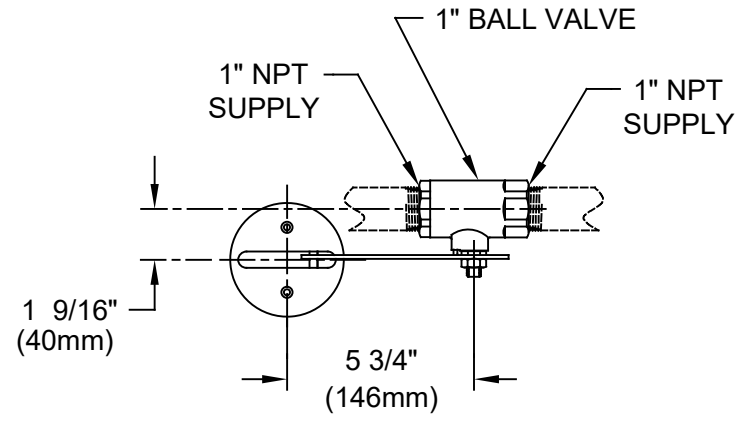
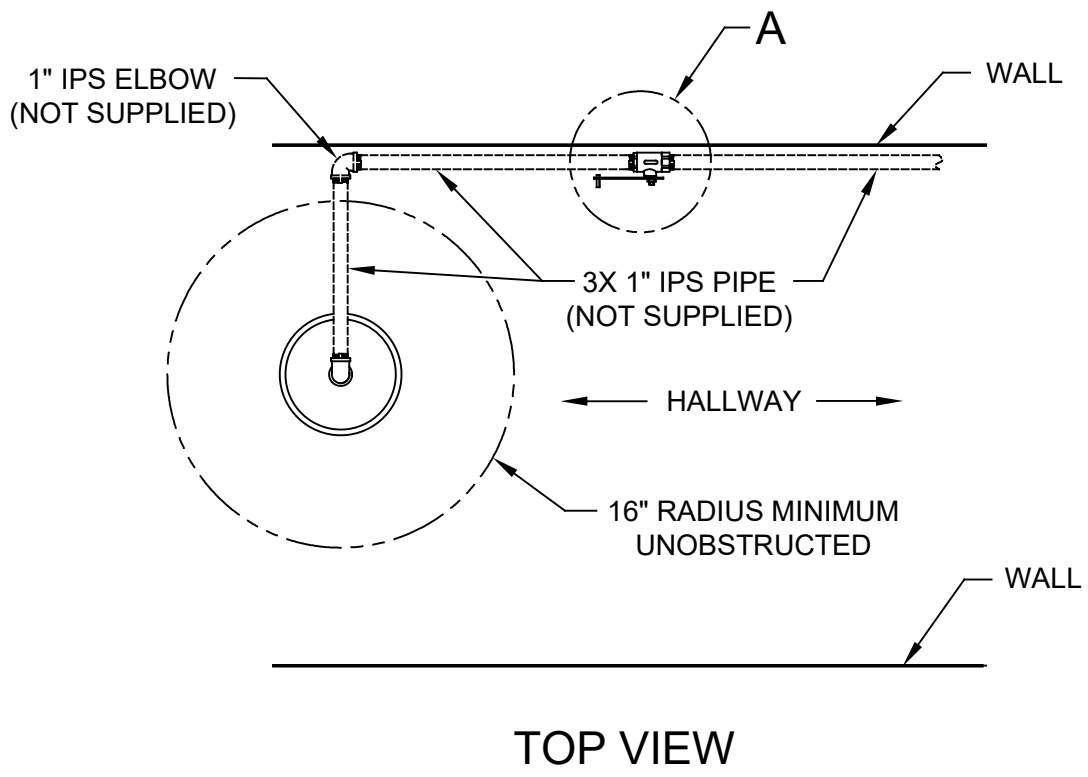

DETAIL A
(ESCUTCHEON)

		1455 KLEPPE LANE SPARKS, NEVADA 89431 (775) 359-4712 FAX (775) 359-7424 E-MAIL: HAWS@HAWSO.COM WEBSITE: WWW.HAWSO.COM	
ECN NO.:	REVISED PER BY:	MODEL(S)	PART NUMBER
ECN: 5925	FV	8163	0002080137.D
DRAWN: DO	DATE: 5/98	CHK'D: JC	REVISION
APPROVED: FV	DATE: 05/31/23	SCALE: NA	9
DRAWING TYPE: INSTALLATION		SIZE: A	SHEET 2 OF 2