

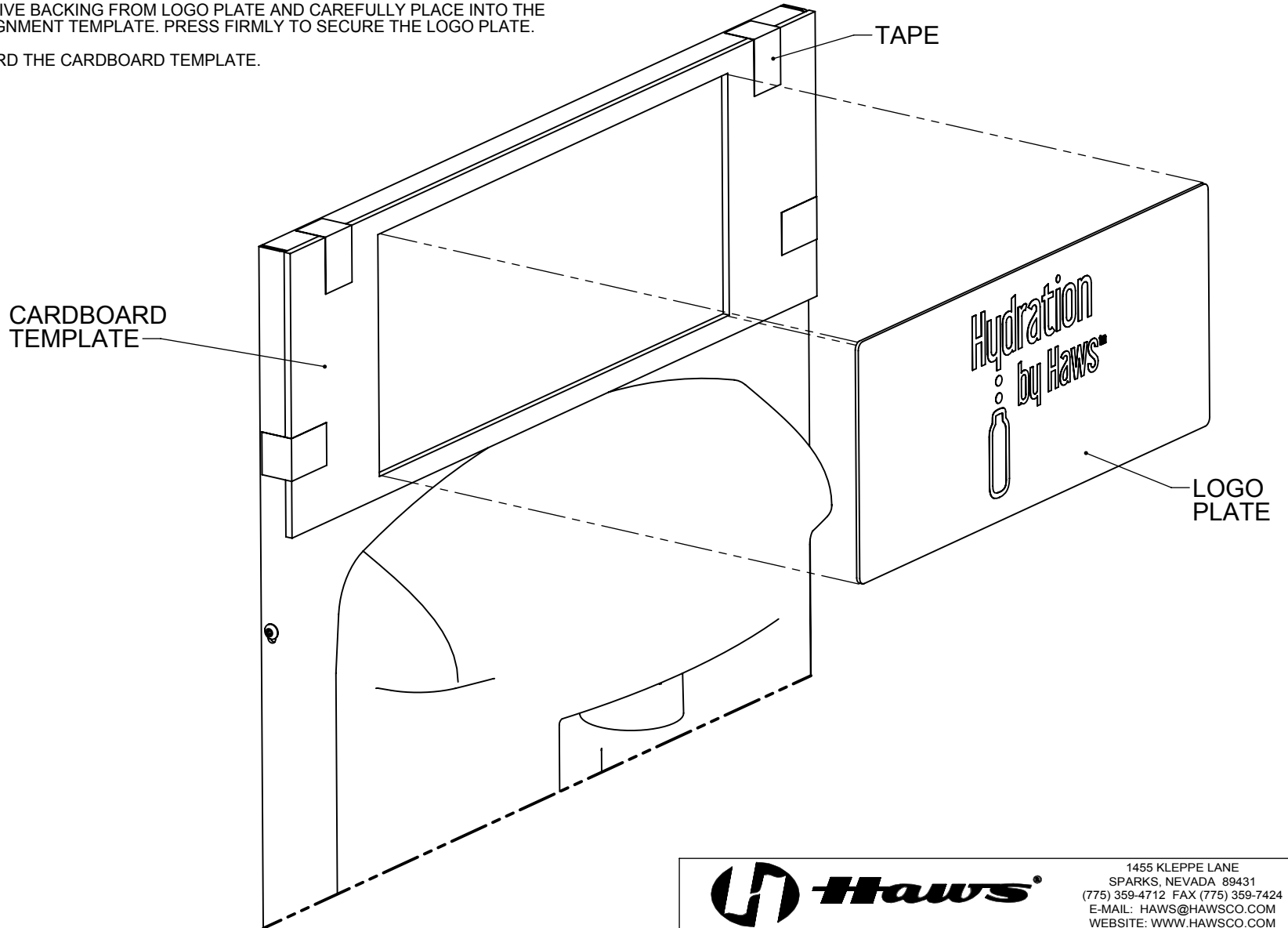

INSTALLATION INSTRUCTIONS FOR LOGO PLATE:

1. CLEAN THE FRONT OF THE BOTTLE FILLER TO REMOVE ANY GREASE OR CONTAMINANTS.
2. TAPE THE CARDBOARD TEMPLATE ONTO FRONT PANEL OF BOTTLE FILLER, ALIGNING THE TOP AND SIDES OF THE TEMPLATE FLUSH WITH THE EDGES OF BOTTLE FILLER PANEL.
3. REMOVE THE ADHESIVE BACKING FROM LOGO PLATE AND CAREFULLY PLACE INTO THE WINDOW OF THE ALIGNMENT TEMPLATE. PRESS FIRMLY TO SECURE THE LOGO PLATE.
4. REMOVE AND DISCARD THE CARDBOARD TEMPLATE.



			1455 KLEPPE LANE SPARKS, NEVADA 89431 (775) 359-4712 FAX (775) 359-7424 E-MAIL: HAWS@HAWSCO.COM WEBSITE: WWW.HAWSCO.COM	
ECN: 5339	REV. ECN: 5339	BY: MJ	MODEL(S)	PART NUMBER
DRAWN: MJ	DATE: 08/15/18	CHKD: MJ	DRAWING, 6475	0580000857.D
APPROVED: MJ	DATE: 08/15/18			REVISION
				1
SCALE: 1:4			DRAWING TYPE: INSTALLATION	SIZE: A
				SHEET 1 OF 1