

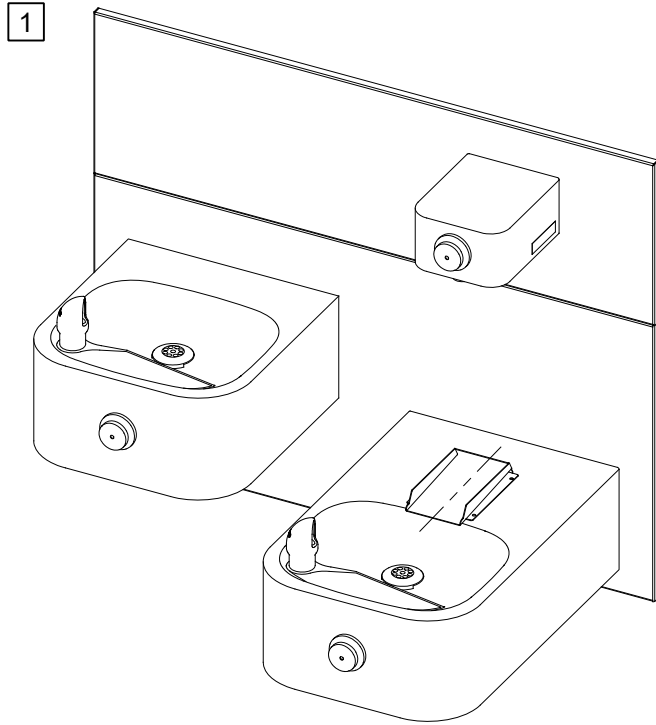

### 6469 STRAINER DRIP TRAY INSTALLATION

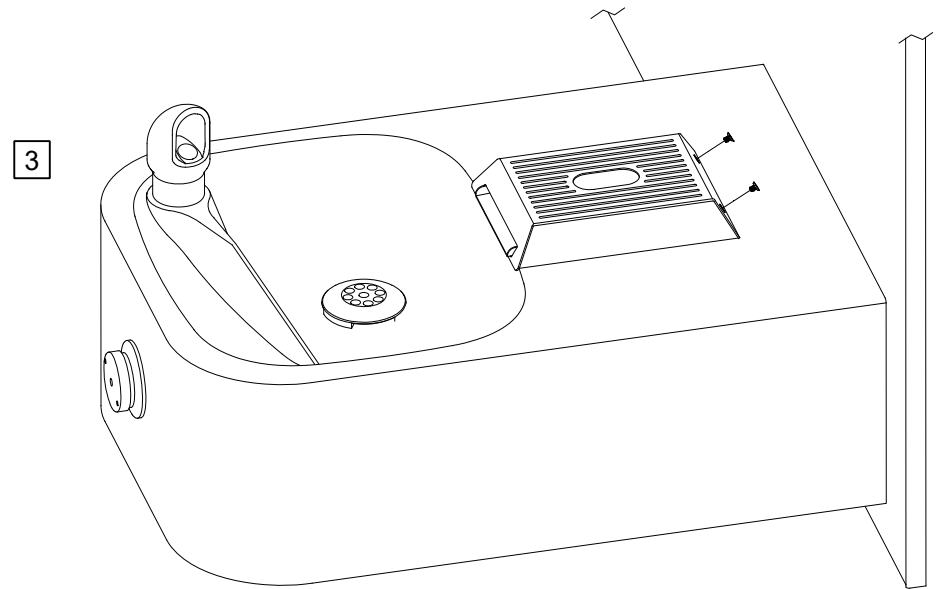

- 1 THE 6469 STRAINER DRIP TRAY ALLOWS THE INSTALLATION OF THE 1920 SERIES BOTTLE FILLER OVER HAWS 1109/1119 SERIES MODEL DRINKING FOUNTAINS. CENTER THE LOWER DRAIN PAN ALONG THE CENTERLINE OF THE FOUNTAIN.
- 2 EXTEND THE FRONT EDGE OF THE LOWER DRAIN PAN OVER THE EDGE OF THE FOUNTAIN BOWL BY APPROXIMATELY 1/4" (6mm). IT IS RECOMMENDED TO TEMPORARILY TAPE THE DRAIN PAN IN PLACE, INSTALL THE TOP COVER, AND ACTIVATE THE BOTTLE FILLER TO VERIFY THE WATER STREAM IS ALIGNED TO THE INLET HOLE. VERIFY THE LIP OF THE TOP COVER HANGS OVER THE EDGE OF THE FOUNTAIN BOWL.
- 3 MARK THE DRAIN PAN HOLE LOCATIONS ON THE FOUNTAIN. THE DRAIN PAN CAN NOW BE PERMANENTLY INSTALLED USING AN APPROPRIATE FASTENING METHOD (FASTENERS NOT SUPPLIED). FASTENING OPTIONS INCLUDE THRU BOLTS, RIVETS, TACK WELDS, AND DOUBLE-SIDED FOAM TAPE. INSTALL THE TOP COVER AND SECURE TO THE DRAIN PAN WITH THE SUPPLIED 4-40 FLAT HEAD SCREWS (QTY. 2).

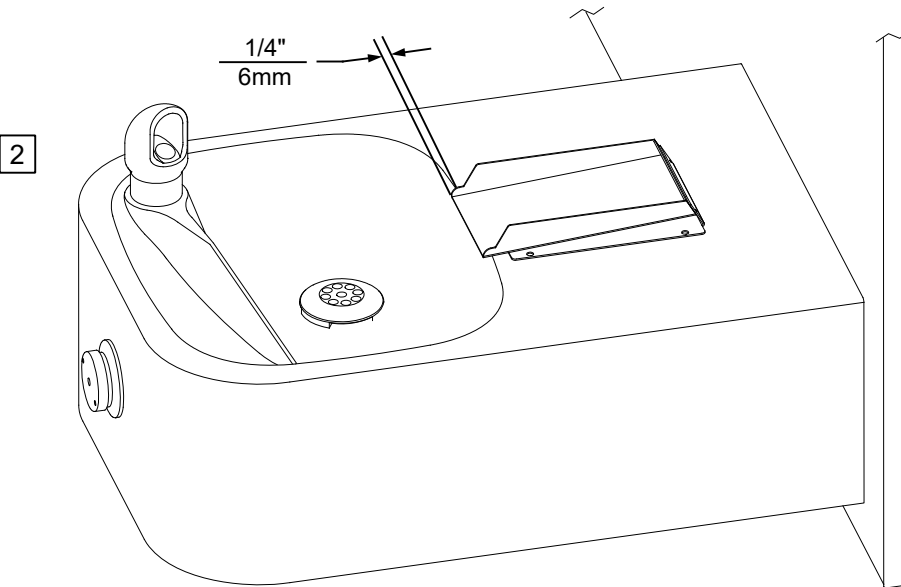

		1455 KLEPPE LANE SPARKS, NEVADA 89431 (775) 359-4712 FAX (775) 359-7424 E-MAIL: HAWS@HAWS.CO.COM WEBSITE: WWW.HAWS.CO.COM	
		ECN NO. 5150 DRAWN: MJ APPROVED: FV	REVISED PER: ECN: 5799 DATE: 01/10/17 DATE: 07/08/22
PART NUMBER 051000657.D			REVISION 2
SCALE: 1:4		DRAWING TYPE: INSTALLATION	SIZE: A SHEET 1 OF 1