

ASSEMBLED 5874PBF
(FLUSH MOUNT APPLICATION ONLY)

SEE SHEET 2 OF 2 FOR 5874PB RECESSED MOUNT INSTRUCTIONS.

*** MODEL VRK5874 & VRK5874HF- VALVE REPAIR KITS INCLUDE THESE ITEMS

INSTALLATION INSTRUCTIONS FOR 5874PBF.

- 1) FOLLOW INSTRUCTIONS CAREFULLY ON O&M MANUAL (PAGE 2 OF 6) WHEN REMOVING OLD VALVE. **NOTE: SEE PARTS BREAKDOWN (PAGE 4 OF 6) FOR ADDITIONAL NOTES.**
- 2) VERIFY THAT LOCK NUT, FIBER, AND RUBBER WASHERS ARE POSITIONED SLIGHTLY PAST MIDWAY OF THREADS ON NEW VALVE BODY.
- 3) INSERT VALVE INTO BRACKET FROM INSIDE AND PUSH FORWARD ABOUT 1".
- [4] THREAD LARGE RING NUT ONTO VALVE BODY, APPROXIMATELY 1" INTO VALVE.
- [5] PLACE WAVE WASHER INSIDE OF FLANGED PUSH BUTTON ASSEMBLY (**MUST BE IN PLACE**).
- [6] APPLY ONE (1) DOT OF LOCTITE 222MS, ON THE FEMALE THREADS OF BUTTON ASSEMBLY LEAVING THE FIRST AND LAST THREADS FREE. (FIGURE 1). **CAUTION: EXCESS LOCTITE CAN CAUSE THREADS TO LOCK VERY TIGHTLY, MAKING REPAIRS DIFFICULT.**
- **7) THREAD FLANGED PUSH BUTTON ASSEMBLY ON VALVE UNTIL WAVE WASHER MAKES SLIGHT CONTACT WITH STEM OF CARTRIDGE. **CAUTION: DO NOT HAND-TIGHTEN.**
- [8] UNTHREAD RING NUT FORWARD UNTIL IT STOPS FLUSH WITH PUSH BUTTON ASSEMBLY.
- [9] PUSH VALVE BACK TOWARD THE INSIDE OF BRACKET AND TIGHTEN LOCKNUT (SEE ILLUSTRATION ABOVE).
- 10) TIGHTEN PUSH BUTTON ASSEMBLY USING UNIVERSAL SPANNER WRENCH PROVIDED.

** OVERTIGHTENING WILL PRE-ACTUATE VALVE AND CAUSE WEEPAGE, WHILE NOT ENOUGH CONTACT BETWEEN WAVE WASHER AND STEM CAN CAUSE A LOW FLOW CONDITION.

* [6] APPLY 1 DOT OF LOCTITE 222MS (WHERE SHOWN)

* THIS ALSO APPLIES TO PBA6/PBA6C

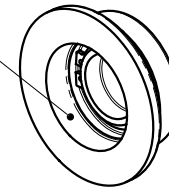
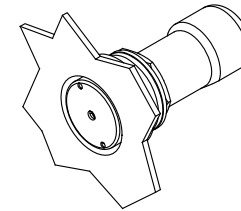
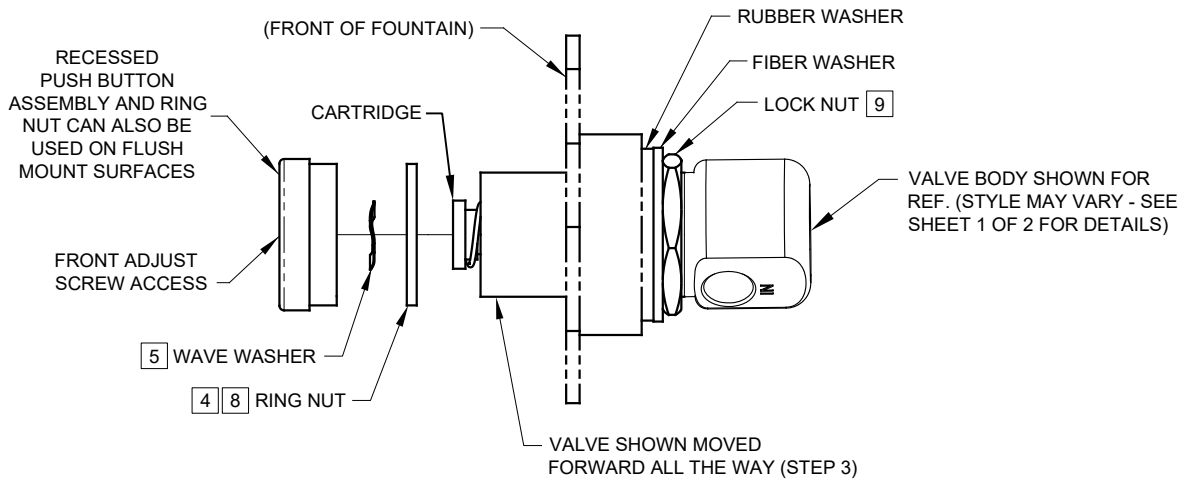

FIGURE 1

NOTE!

THIS VALVE IS PRESSURE COMPENSATING. BE SURE TO REMOVE ANY EXISTING FLOW CONTROL DEVICES. (MAY BE PRESENT IN FITTING OR SPUD).

		1455 KLEPPE LANE SPARKS, NEVADA 89431 (775) 359-4712 FAX (775) 359-7424 E-MAIL: HAWS@HAWS.CO.COM WEBSITE: WWW.HAWS.CO.COM	
		ECN NO. 4250 DRAWN: LM APPROVED: FV	REVISED PER: ECN: 5664 DATE: 06/08/16 DATE: 03/02/21
PART NUMBER 0002077650.D			REVISION 10
SCALE: NA		DRAWING TYPE: INSTALLATION	SIZE: A SHEET 1 OF 2



ASSEMBLED 5874PB
(RECESSED MOUNT APPLICATION SHOWN)
SEE SHEET 1 OF 2 FOR FLUSH MOUNT INSTRUCTIONS.

INSTALLATION INSTRUCTIONS FOR 5874PB.

- 1) FOLLOW INSTRUCTIONS CAREFULLY ON O&M MANUAL (PAGE 2 OF 6) WHEN REMOVING OLD VALVE. **NOTE: SEE PARTS BREAKDOWN (PAGE 4 OF 6) FOR ADDITIONAL NOTES.**
 - 2) VERIFY THAT LOCK NUT, FIBER WASHER, AND RUBBER WASHERS ARE POSITIONED TOWARD BOTTOM END OF THREADS ON NEW VALVE BODY.
 - 3) INSERT VALVE INTO BRACKET FROM INSIDE, AND PUSH ALL THE WAY FORWARD (SEE ILLUSTRATION ABOVE).
 - 4) THREAD RING NUT ONTO VALVE BODY, AS FAR IN AS POSSIBLE, TOWARD FRONT OF FOUNTAIN. **NOTE: IF REPLACING A 5871 OR 5872 SERIES VALVE, YOU MAY HAVE TO CONTACT HAWS TECHNICAL SUPPORT.**
 - 5) PLACE WAVE WASHER INSIDE OF PUSH BUTTON ASSEMBLY (**MUST BE IN PLACE**).
 - 6) APPLY ONE (1) DOT OF LOCTITE 222MS, ON THE FEMALE THREADS OF BUTTON ASSEMBLY LEAVING THE FIRST AND LAST THREADS FREE. (FIGURE 1). **CAUTION: EXCESS LOCTITE CAN CAUSE THREADS TO LOCK VERY TIGHTLY, MAKING REPAIRS DIFFICULT.**
 - **7) THREAD PUSH BUTTON ASSEMBLY ON VALVE UNTIL WAVE WASHER MAKES SLIGHT CONTACT WITH STEM OF CARTRIDGE. **CAUTION: DO NOT HAND-TIGHTEN.**
 - 8) UNTHREAD RING NUT FORWARD UNTIL IT STOPS FLUSH WITH PUSH BUTTON ASSEMBLY.
 - 9) PUSH VALVE BACK TOWARD THE INSIDE OF BRACKET AND TIGHTEN LOCKNUT (SEE ILLUSTRATION ABOVE).
 - 10) TIGHTEN PUSH BUTTON ASSEMBLY USING UNIVERSAL SPANNER WRENCH PROVIDED.
- ** OVERTIGHTENING WILL PRE-ACTUATE VALVE AND CAUSE WEEPAGE, WHILE NOT ENOUGH CONTACT BETWEEN WAVE WASHER AND STEM CAN CAUSE A LOW FLOW CONDITION.

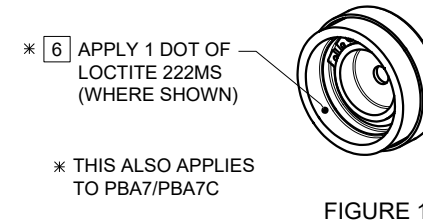

FIGURE 1

NOTE!

THIS VALVE IS PRESSURE COMPENSATING. BE SURE TO REMOVE ANY EXISTING FLOW CONTROL DEVICES. (MAY BE PRESENT IN FITTING OR SPUD).

		Haws®		1455 KLEPPE LANE SPARKS, NEVADA 89431 (775) 359-4712 FAX (775) 359-7424 E-MAIL: HAWS@HAWS.CO.COM WEBSITE: WWW.HAWS.CO.COM	
				MODEL(S) 5874PB/5874PBF/VRK5874/VRK5874HF/ PBA6/PBA6C/PBA7/PBA7C	
ECN NO. 4250	REVISED PER ECN: 5664	BY: FV	PART NUMBER 0002077650.D		REVISION
DRAWN: LM	DATE: 08/08/16	CHK'D: JL	10		
APPROVED: FV	DATE: 03/02/21	SCALE: NA	DRAWING TYPE: INSTALLATION	SIZE: A	SHEET 2 OF 2