

NOTES:

- 1 IF NEEDED, WHEN RE-ASSEMBLING VALVE TIGHTEN DOWN ON (EXISTING) 3/8"-24 LOCK NUT USING A 9/16" BOX WRENCH AND A 5/32" ALLEN WRENCH (TO KEEP VALVE STEM (ITEM 14) FROM TURNING) UNTIL ACHIEVING A SLIGHT PLAY ON HANDLE. CAUTION: DO NOT OVER TIGHTEN NUT. VALVE WILL LEAK.
- 2 LUBRICATE WITH GREASE BEFORE ASSEMBLY.
- 3 SECURE CAP (ITEM 1) WITH SET SCREW (ITEM 19) USING A 1/16" ALLEN WRENCH.

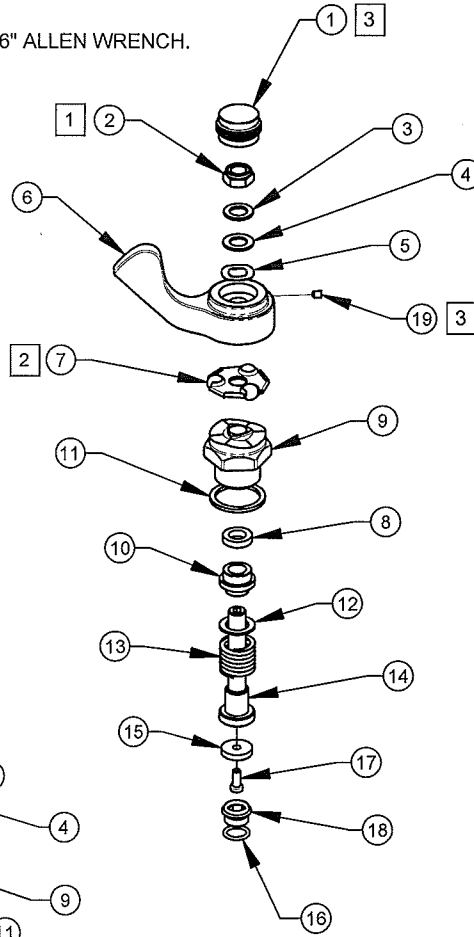
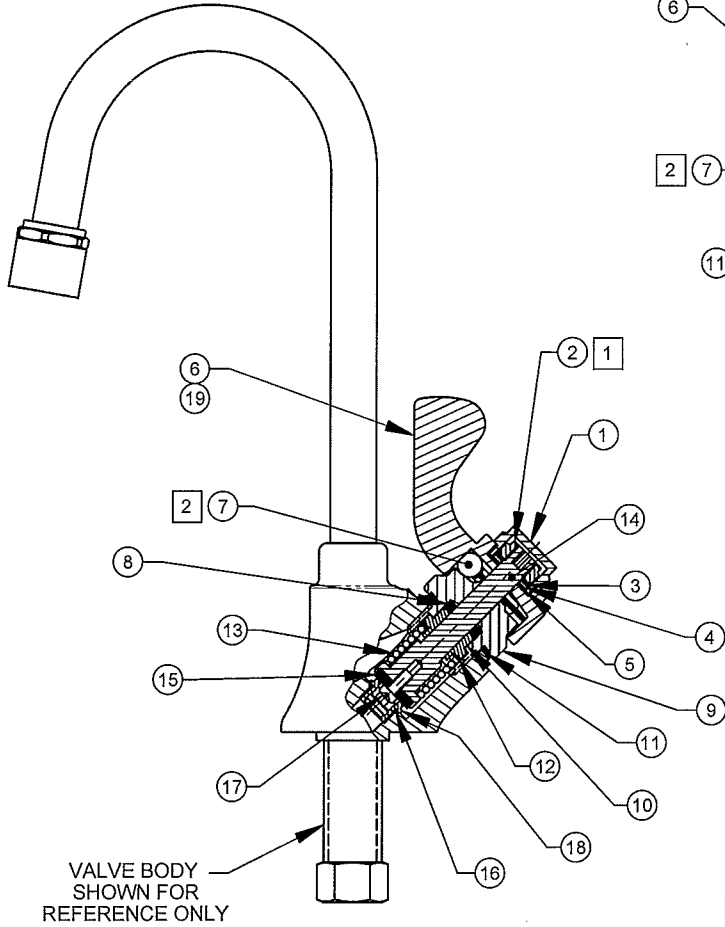

EXPLODED VIEW

FOR MODEL:
5452LF

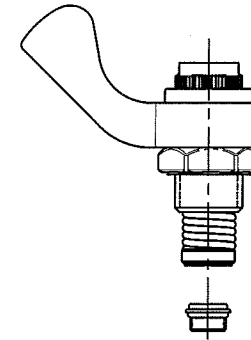

ASSEMBLED VIEW

19	0005063885	SCREW, SET 6-32 UNC
18	0005208682	SEAT F/5830HST
17	0005064870	SCREW, 8-32 X 3/8"
16	0003981050	O-RING, .426 X .070 WALL
15	0006634576	WASHER, .660 X .170 X .125
14	0005532750	STEM, VALVE
13	0005425392	SPRING, .73 X 1.25 X 2.50mm
12	0006634380	WASHER, .75 X .494 X .040
11	0006634184	WASHER, 1.165 X .951 X .073
10	0002583484	GLAND
9	0000356123	BONNET, FAUCET
8	0002582902	GLAND PACKING
7	0000192993	BEARING SET
6	0002689126	HANDLE, LEVER F/5452LF
5	0006626653	WASHER, WAVE 5/16"
4	0006633792	WASHER, .650 X .380 X .040
3	0006633596	WASHER, .625 X .390 X .048
2	0003801119	NUT, 3/8-24 UNF NYLON LOCK
1	0001464267	INDEX CAP
ITEM	PART NO.	DESCRIPTION

ECN NO. REVISED PER BY: ECN: 4689 HX
 DRAWN: RTM DATE: 03/01/04 CHK'D:
 APPROVED: DATE:

Haws[®]

MODEL(S)
5452HST
HANDLE/STEM ASSEMBLY

1455 KLEPPE LANE
 SPARKS, NEVADA 89431
 (775) 359-4712 FAX (756) 359-7424
 E-MAIL: HAWS@HAWSO.COM
 WEBSITE: WWW.HAWSO.COM

PART NUMBER	0002080004
DRAWING NO.	15248A00
REV	2

SCALE: 1:1 | DRAWING TYPE: INSTALLATION | SIZE: A | SHEET 1 OF 1