

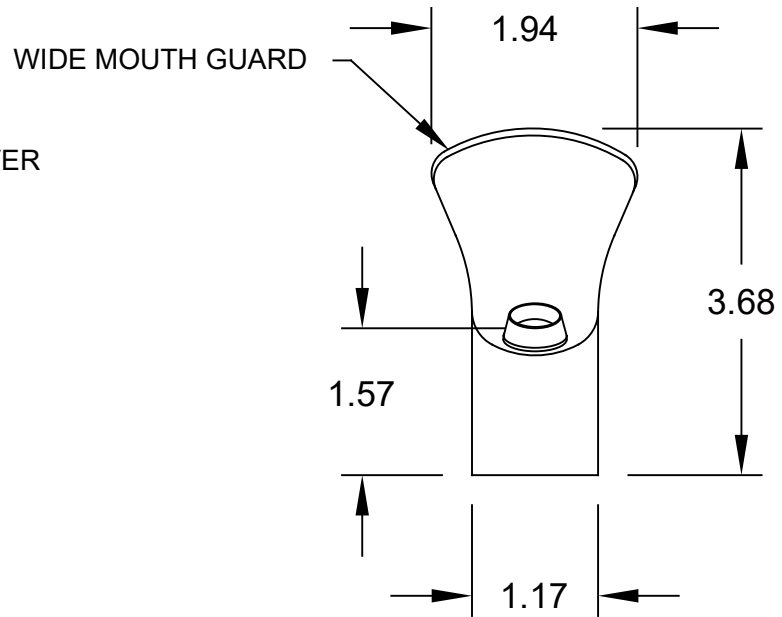

**NOTES:**

TO ADJUST FLOW:

1. REMOVE HEX NUT COVER AND PUSH BUTTON COVER.
2. ADJUST WITH SCREWDRIVER: CLOCKWISE TO INCREASE FLOW & COUNTER-CLOCKWISE TO DECREASE FLOW.
3. IF DESIRED FLOW IS NOT OBTAINED, CLEAN SCREEN AT INLET (SEE 5010SS OPERATION AND MAINTENANCE MANUAL FOR ACCESS INSTRUCTIONS).
4. REPLACE PUSH BUTTON COVER AND HEX NUT COVER.

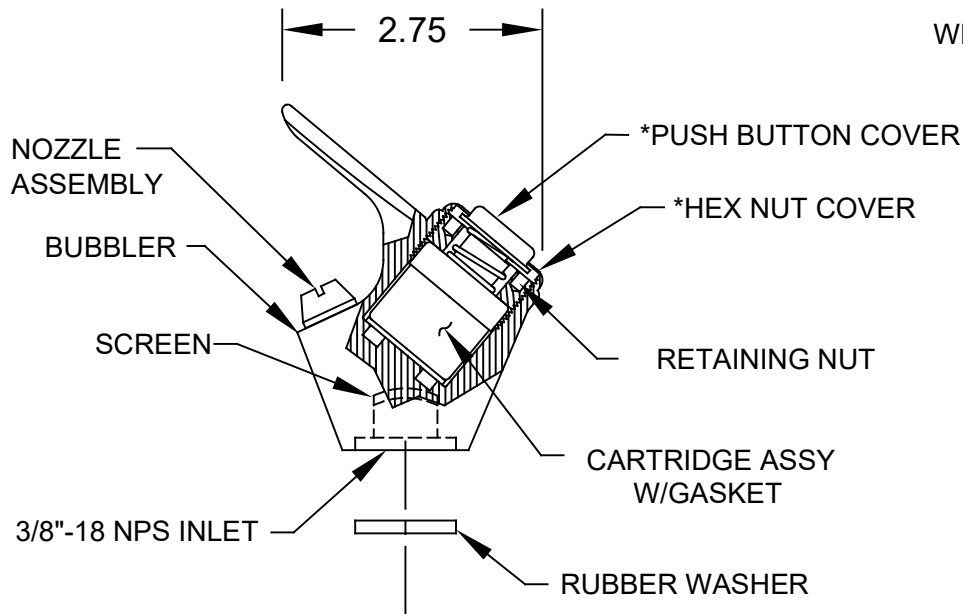
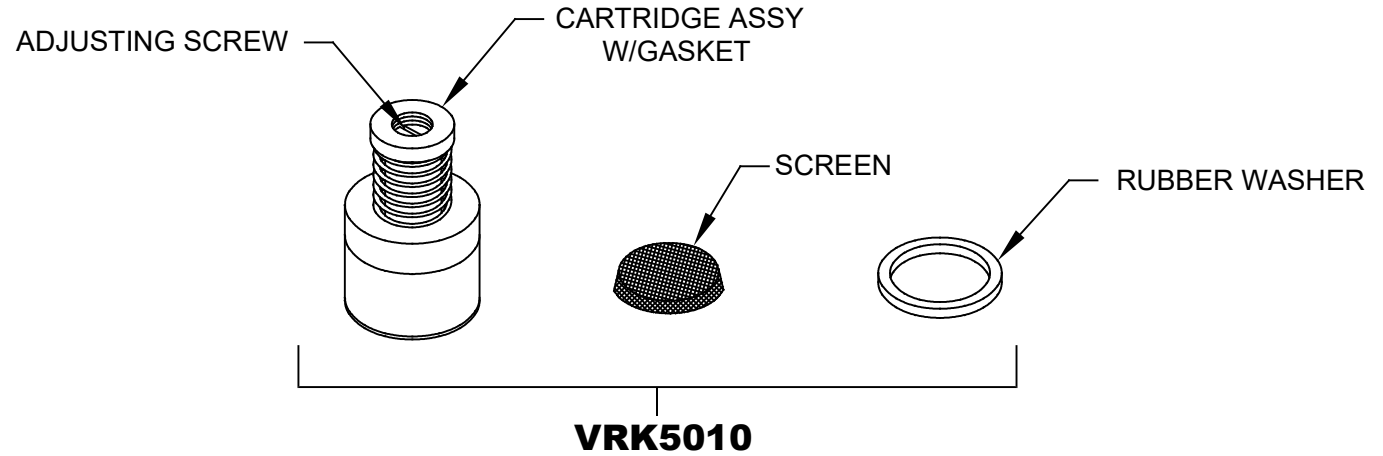

\*CHROME PLATED PUSH BUTTON COVER & NUT ARE STANDARD ON 5010SS. COPPER PLATED OPTION IS AVAILABLE AS MODEL PB8C.

		<b>Haws</b> <sup>®</sup>		1455 KLEPPE LANE SPARKS, NEVADA 89431 (775) 359-4712 FAX (755) 359-7424 E-MAIL: HAWS@HAWS.CO.COM WEBSITE: WWW.HAWS.CO.COM	
				ECN NO. 4215 DRAWN: SLS APPROVED: FV	REVISED PER: ECN: 5913 DATE: 01/14/99 DATE: 07/18/23
SCALE: 1:1		DRAWING TYPE: INSTALLATION		SIZE: A SHEET 1 OF 1	