

**REPLACEMENT INSTRUCTIONS:**

1. **REQUIRED TOOLS:** PHILLIPS SCREWDRIVER (OR 5/16 NUT DRIVER), 1/4" BIT DRIVER, T20 TORX BIT (SUPPLIED).
2. DISCONNECT ELECTRICAL POWER TO UNIT.
3. IF DRAIN BASIN HAS A STAINLESS STEEL GRATE, REPLACE THE LOWER BRACKETS ON THE BOTTLE FILLER (SEE DIAGRAM BELOW)) WITH THE INCLUDED SHORTER BRACKETS.
4. REMOVE THE COOLER SKIRT(S).
5. IF A HI-LO UNIT IS INSTALLED, THE HIGH UNIT MAY NEED TO BE REMOVED IN ORDER TO ACCESS THE MOUNTING SCREW ON THE LEFT SIDE OF BOTTLE FILLER. REFER TO DIAGRAM AT RIGHT, AND TO COOLER OPERATION AND MAINTENANCE MANUAL.
6. REMOVE BOTH MOUNTING SCREWS.
7. DISCONNECT BOTTLE FILLER INLET TUBING FROM ELBOW CONNECTOR. REMOVE LOWER PIECE OF TUBING INSULATION.
8. SLIDE BOTTLE FILLER UP AND AWAY FROM UPPER MOUNTING BRACKET UNTIL WIRING HARNESS CONNECTOR IS ACCESSIBLE. DISCONNECT THE WIRING HARNESS.
9. ASSEMBLE THE NEW BOTTLE FILLER, REVERSING STEPS 4-8. TRIM LENGTH OF 1/4" WATER TUBING AND SUPPLIED INSULATION IF NECESSARY.
10. RECONNECT ELECTRICAL POWER TO THE UNIT
11. RUN THE BOTTLE FILLER TO PURGE AIR FROM THE SYSTEM.

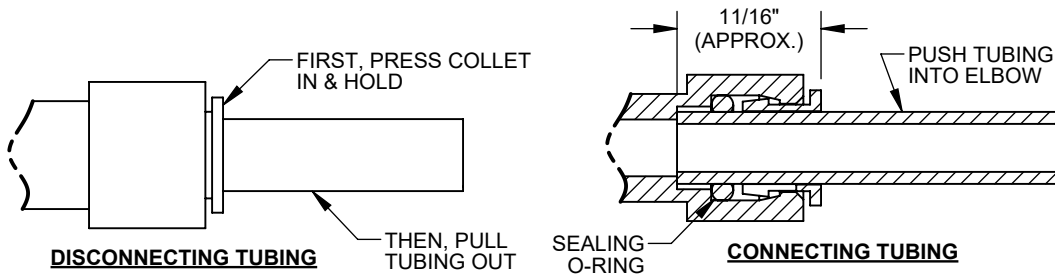

**DISCONNECTING & RE-CONNECTING TUBING**

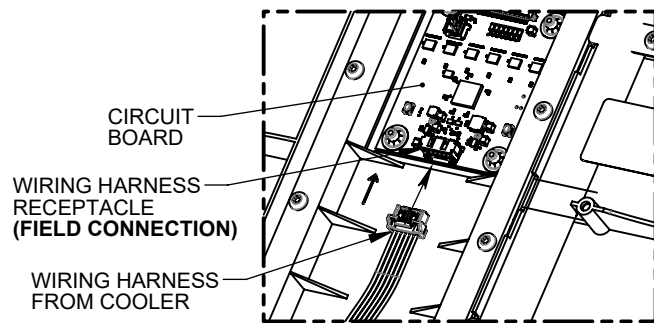

**WIRING HARNESS CONNECTION (REAR OF BOTTLE FILLER)**

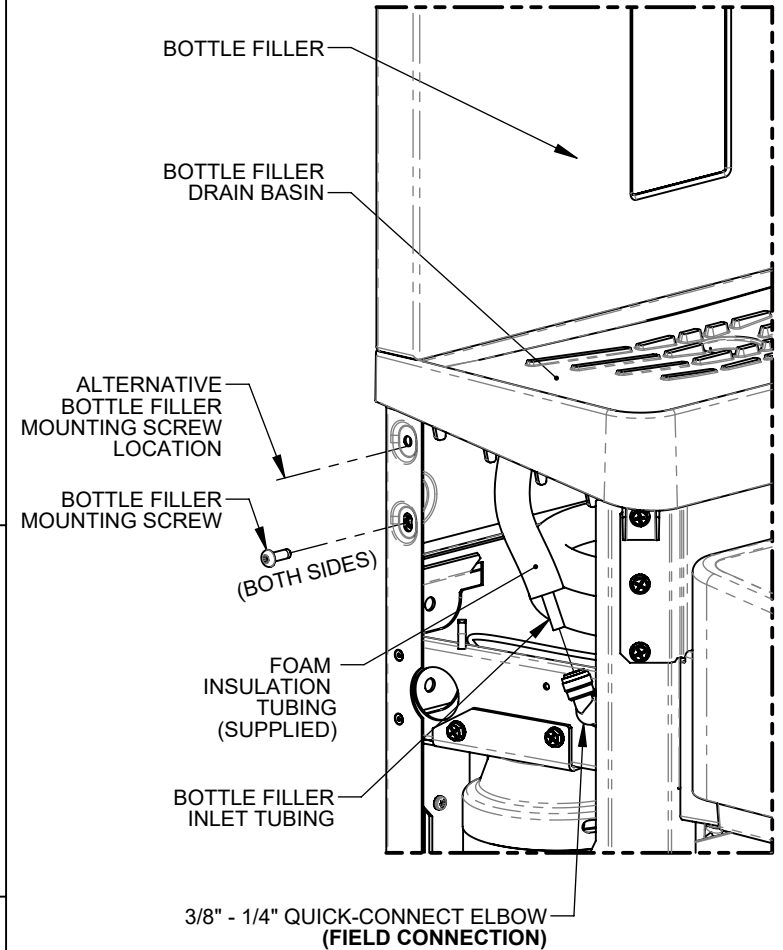
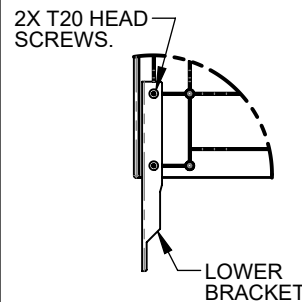

**BOTTLE FILLER MOUNTING & TUBING CONNECTION**



1455 KLEPPE LANE  
 SPARKS, NEVADA 89431  
 (775) 359-4712 FAX (775) 359-7424  
 E-MAIL: HAWS@HAWSO.COM  
 WEBSITE: WWW.HAWSO.COM

ECN: 5357	REV. ECN: 5656	BY: DHP	MODEL(S):	PART NUMBER:
DRAWN: JL	DATE: 07/25/18	CHKD: DHP	1930 - REPLACEMENT 12XX BOTTLE FILLER	0510000959
APPROVED: JL	DATE: 02/11/21			REVISION:
				3
SCALE: 1:2			DRAWING TYPE: INSTALLATION	SIZE: A
				SHEET 1 OF 1