

1920FR MOUNTING HOLE LOCATIONS

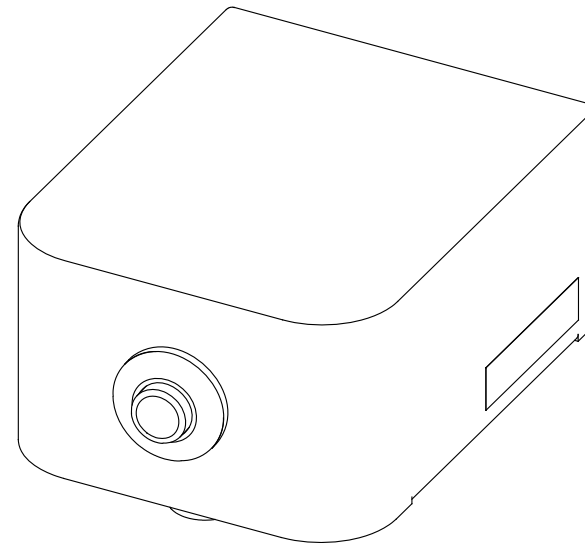
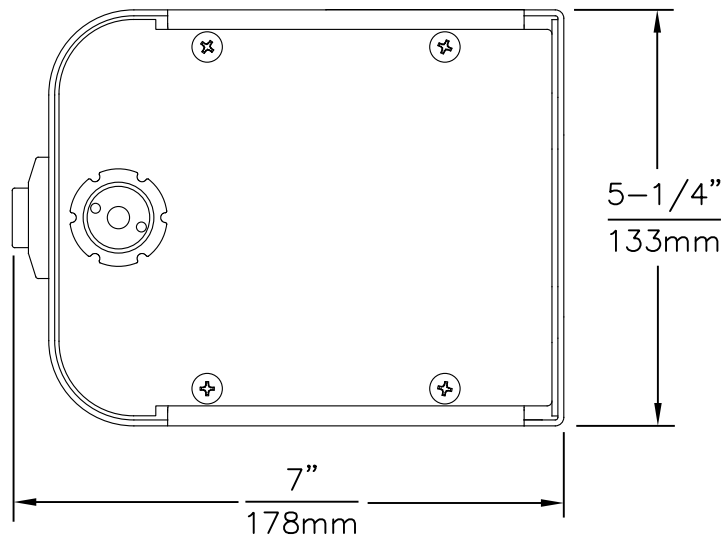

NOTES:

- 1 THIS BOTTLE FILLER REQUIRES THE USE OF MODEL 6521FR FREEZE RESISTANT VALVE ASSEMBLY (SOLD SEPERATELY OR AS PART OF PRODUCT BUNDLES).
- 2 VALVE ASSEMBLY MUST BE INSTALLED IN A WARM AREA. PROVISIONS SHOULD BE MADE TO ALLOW ACCESS TO THE ACCESS PANEL.
3. SEE SEPERATE INSTALLATION DRAWINGS FOR FOUNTAINS, MOUNTING PLATES, BACKPANELS, AND DRIP TRAY. HOLD ROUGH-IN DIMENSIONS $\pm 1/8"$ (3.2mm).
4. WHEN INSTALLING THIS UNIT, LOCAL, STATE OR FEDERAL CODES SHOULD BE ADHERED TO. FOR INSTALLATION HEIGHTS OTHER THAN SHOWN, DIMENSIONS MARKED (*) MUST BE ADJUSTED ACCORDINGLY.

		1455 KLEPPE LANE SPARKS, NEVADA 89431 (775) 359-4712 FAX (775) 359-7424 E-MAIL: HAWS@HAWS.CO.COM WEBSITE: WWW.HAWS.CO.COM			
				ECN NO. 5081 ECN: 5799 DRAWN: DS APPROVED: FV	REVISED PER: FV DATE: 05/25/16 CHKD: JS DATE: 07/08/22
SCALE: N/A		DRAWING TYPE: INSTALLATION		SIZE: A	SHEET 1 OF 3

NOTES:
SEE SHEET 1

3/8" OD POLYPROPYLENE TUBING
(CONNECT TO NOZZLE WITH
SUPPLIED PUSH-IN ELBOW,
TRIM TO FIT.)

7/8" OD INSULATING TUBING (MUST COVER
ENTIRE SUPPLY TUBING, FROM THE
NOZZLE TO MODEL 6521FR ASSEMBLY)
TRIM TO FIT.

CONNECT AIR LINE TO BOTTLE
FILLER PUSH BUTTTON, TRIM TO FIT.

1/2" IPS SUPPLY
(NOT SUPPLIED)

1-1/4" IPS
WASTE (NOT
SUPPLIED)

6700 MOUNTING PLATE
(BEHIND FINISH WALL)
- OR -
6700R RETROFIT PLATE
(ON TOP OF FINISH WALL)
BOTH SOLD SEPARATELY

BP15
BACK PANEL
(NOT SUPPLIED)

6469
DRIP
TRAY
(NOT
SUPPLIED)

(47-5/8")
(1210mm)
BUTTON
HEIGHT
FOR ADA
COMPLIANCE

BP3
BACK PANEL
(NOT
SUPPLIED)

27"
686mm

1920FR
DRINKING
FOUNTAIN
SHOWN FOR
REF. ONLY
(NOT SUPPLIED)

6521FR FREEZE RESISTANT
VALVE ASSEMBLY
(NOT SUPPLIED)
FOR DRINKING FOUNTAIN

(7")
(178mm) (4")
(102mm) DEPTH
OF BOX

6521FR FREEZE RESISTANT
VALVE ASSEMBLY
(NOT SUPPLIED) 1 2
FOR BOTTLE FILLER

6521 VALVE ASSEMBLY
ACCESS PANEL 2

34-1/2"
876mm

17-1/4"
438mm

37-1/2"
952mm

39-1/2"
1003mm

INSTALLATION SHOWN ABOVE HAWS MODEL 1109FR



1455 KLEPPE LANE
SPARKS, NEVADA 89431
(775) 359-4712 FAX (775) 359-7424
E-MAIL: HAWS@HAWSCO.COM
WEBSITE: WWW.HAWSCO.COM

ECN NO: 5081	REVISED PER: ECN: 5799	BY: FV	MODEL(S)	PART NUMBER
DRAWN: MJ	DATE: 02/13/17	CHKD.: JS	1920FR	0510000491.D
APPROVED: FV	DATE: 07/08/22	SCALE: N/A	DRAWING TYPE: INSTALLATION	REVISION 6
			SIZE: A	SHEET 2 OF 3

NOTES:
SEE SHEET 1

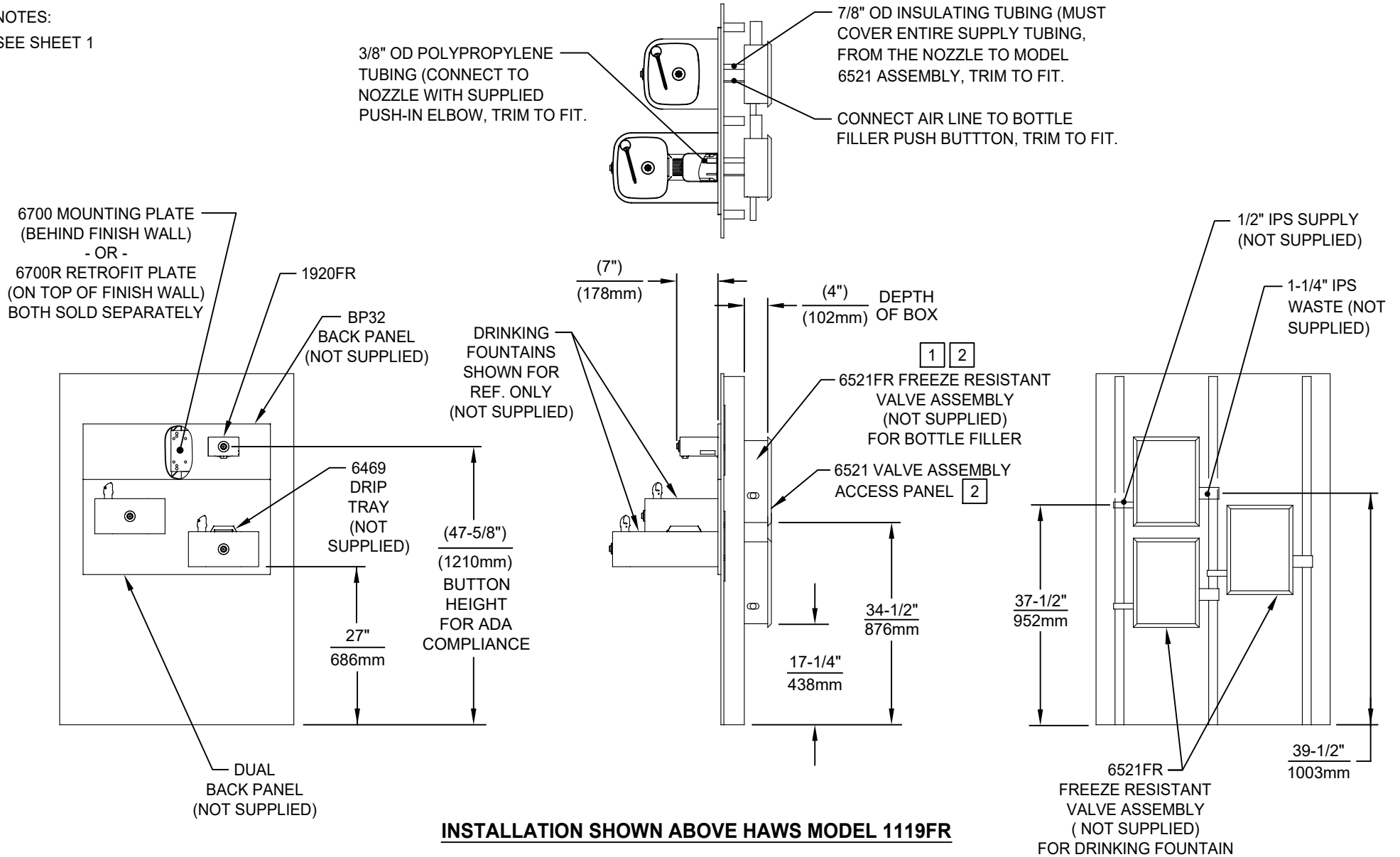



Haws

1455 KLEPPE LANE
SPARKS, NEVADA 89431
(775) 359-4712 FAX (775) 359-7424
E-MAIL: HAWS@HAWS.CO.COM
WEBSITE: WWW.HAWS.CO.COM

ECN NO: 5081	REVISED PER: ECN: 5799	BY: FV	MODEL(S) 1920FR	PART NUMBER 051000491.D
DRAWN: MJ	DATE: 02/13/17	CHK'D: JS		REVISION 6
APPROVED: FV	DATE: 07/08/22	SCALE: N/A	DRAWING TYPE: INSTALLATION	SHEET 3 OF 3