

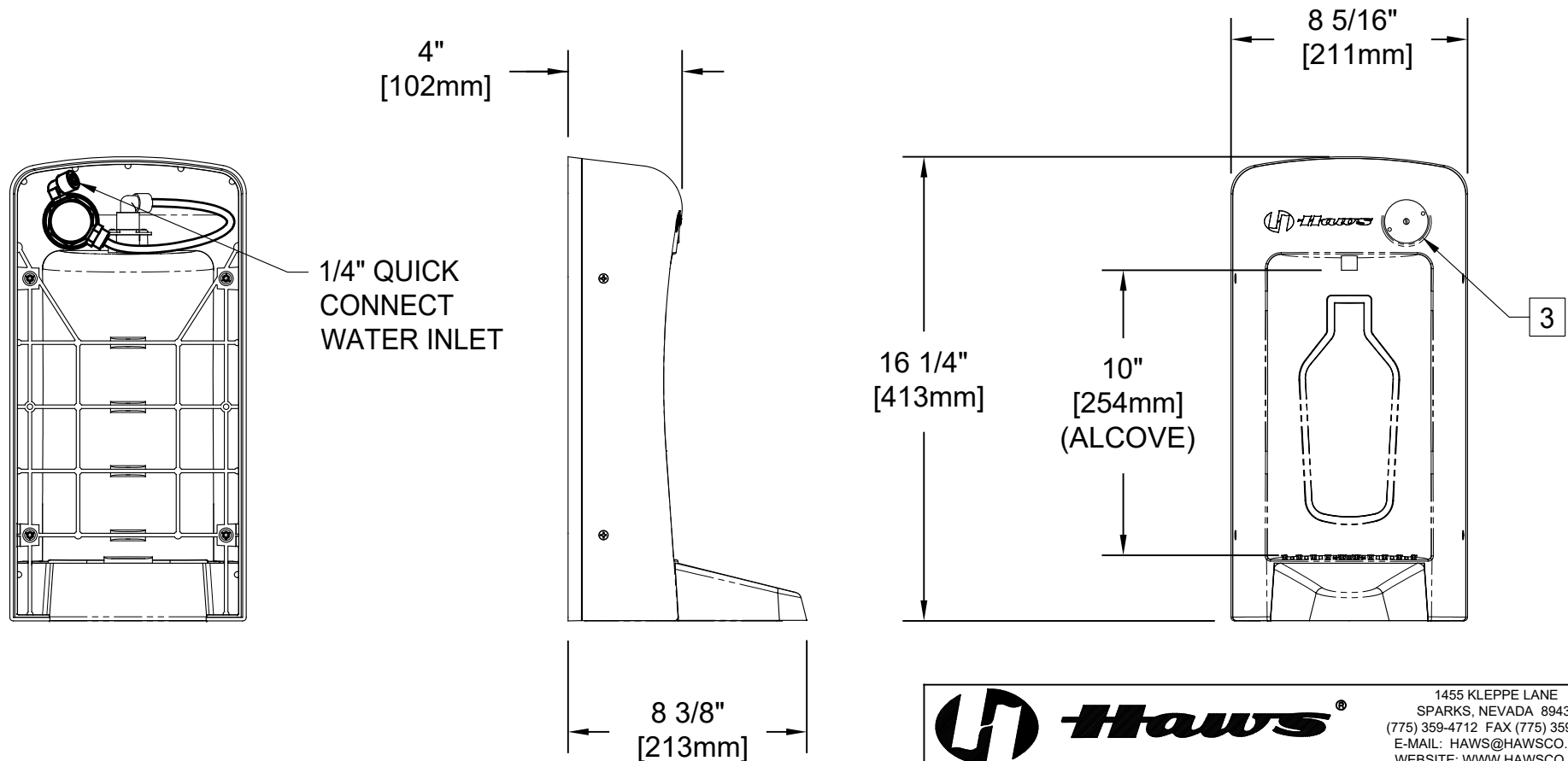

NOTES:

1. HOLD ROUGH-IN DIMENSIONS $\pm 1/4"$ (6.4mm).
2. WHEN INSTALLING THIS UNIT, LOCAL, STATE, OR FEDERAL CODES SHOULD BE ADHERED TO. FOR INSTALLATION HEIGHTS OTHER THAN SHOWN, DIMENSIONS MARKED (*) MUST BE ADJUSTED ACCORDINGLY. INSTALL A TRAP IN THE WASTE LINE AND A SCREWDRIVER STOP IN THE SUPPLY LINE IF REQUIRED.
- 3 REFER TO 5874 SERIES OPERATION & MAINTENANCE MANUAL FOR PUSH BUTTON AND VALVE INSTALLATION & MAINTENANCE INSTRUCTIONS.
- 4 BOTTLE FILLER IS SHOWN INSTALLED AT ADA MAXIMUM OBSTRUCTED FORWARD REACH HEIGHT. FOR ADA OBSTRUCTED SIDE REACH COMPLIANCE, BOTTLE FILLER MUST BE LOWERED 2". ADA COMPLIANCE DEPENDS ON OVERALL SIZE OF WATER COOLER OR DRINKING FOUNTAIN (SEE SHEETS 3 & 4).



| | | | |
|---|--|---|---|
|  | | 1455 KLEPPE LANE SPARKS, NEVADA 89431 (775) 359-4712 FAX (775) 359-7424 E-MAIL: HAWS@HAWS.CO.COM WEBSITE: WWW.HAWS.CO.COM | |
| | | ECN NO. 4855 DRAWN: JL APPROVED: FV | REVISED PER: ECN: 5766 DATE: 2/10/14 DATE: 02/03/22 |
| SCALE: 1:1 DRAWING TYPE: INSTALLATION SIZE: A | | | PART NUMBER: 0002076963.D REVISION: 5 SHEET 1 OF 4 |

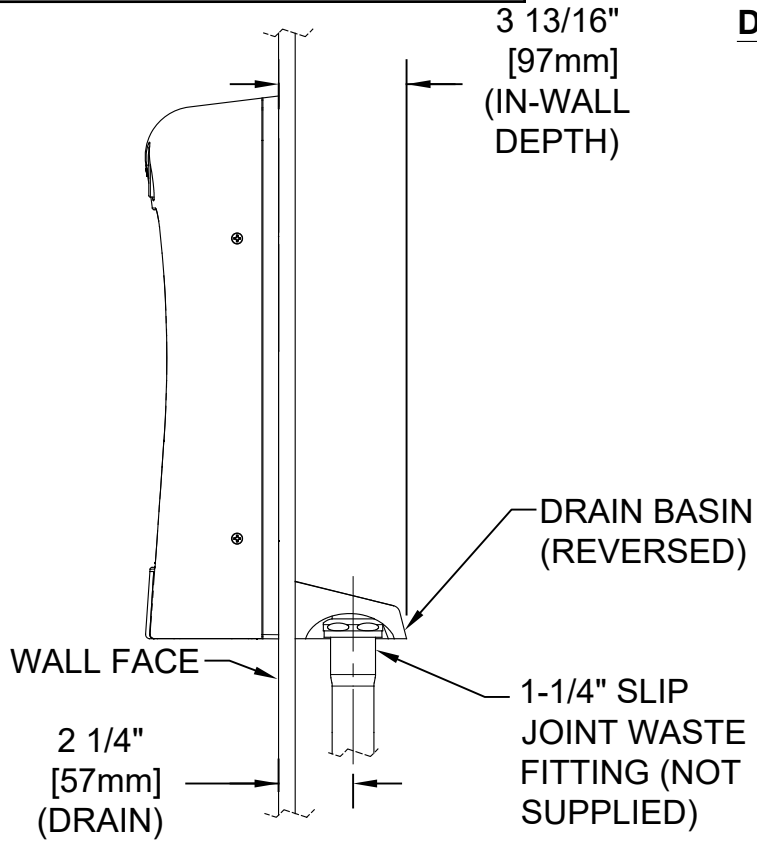

DRAIN SETUP

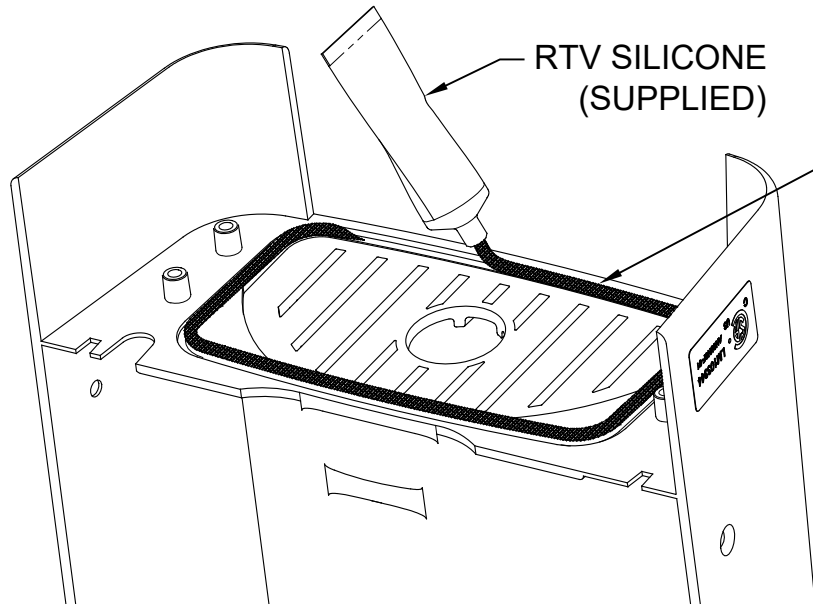
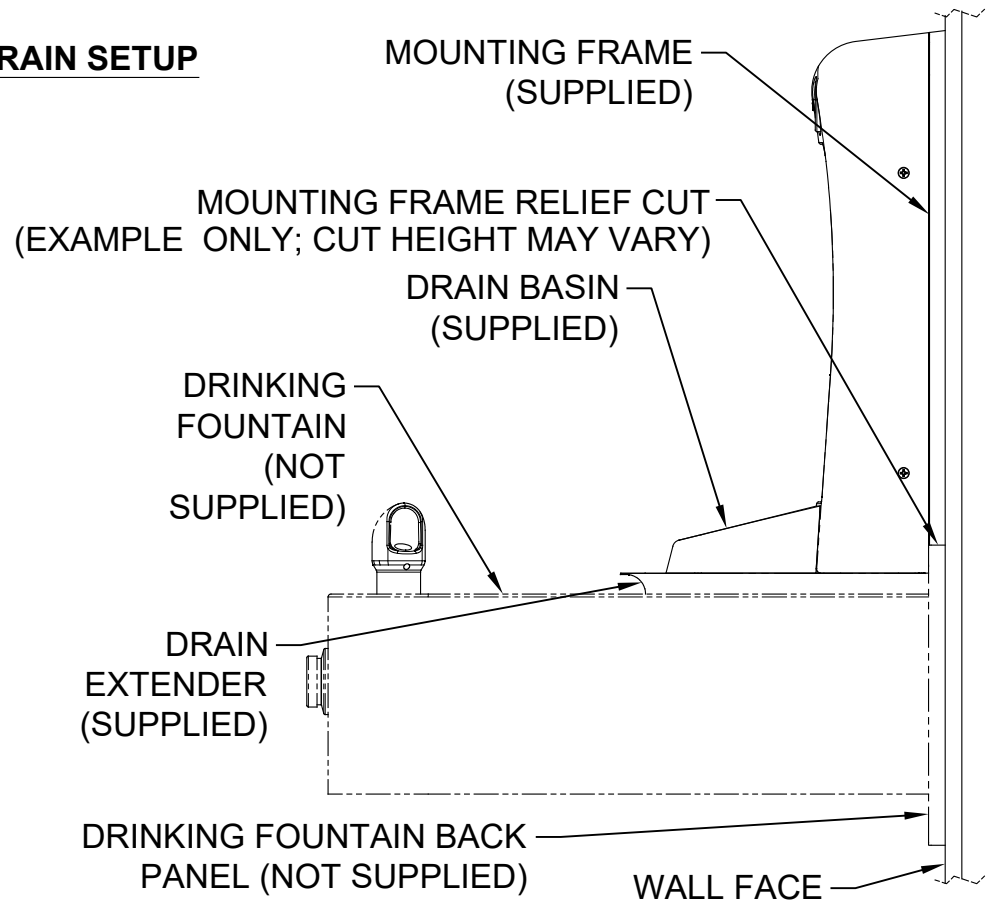

DRAIN SEAL DETAIL

RUN A 1/8"-3/16" DIAMETER BEAD OF RTV RIGHT ALONGSIDE THE GROOVE, BUT NOT IN THE GROOVE. CHECK THE RTV BEAD FOR THIN SECTIONS, GAPS, OR AREAS WHERE THE BEAD DOES NOT TOUCH THE PLASTIC - FILL THESE IN WITH RTV.

| | | | | | |
|--|--|--|---|--|----------------------|
|  Haws [®] | | | 1455 KLEPPE LANE SPARKS, NEVADA 89431 (775) 359-4712 FAX (775) 359-7424 E-MAIL: HAWS@HAWSCO.COM WEBSITE: WWW.HAWSCO.COM | | |
| | | | ECN NO. 4855 DRAWN: JL APPROVED: FV | REVISED PER: FV DATE: 2/10/14 DATE: 02/03/22 | BY: FV CHKD.: BJM |
| SCALE: 1:1 | | | DRAWING TYPE: INSTALLATION | SIZE: A | SHEET 2 OF 4 |

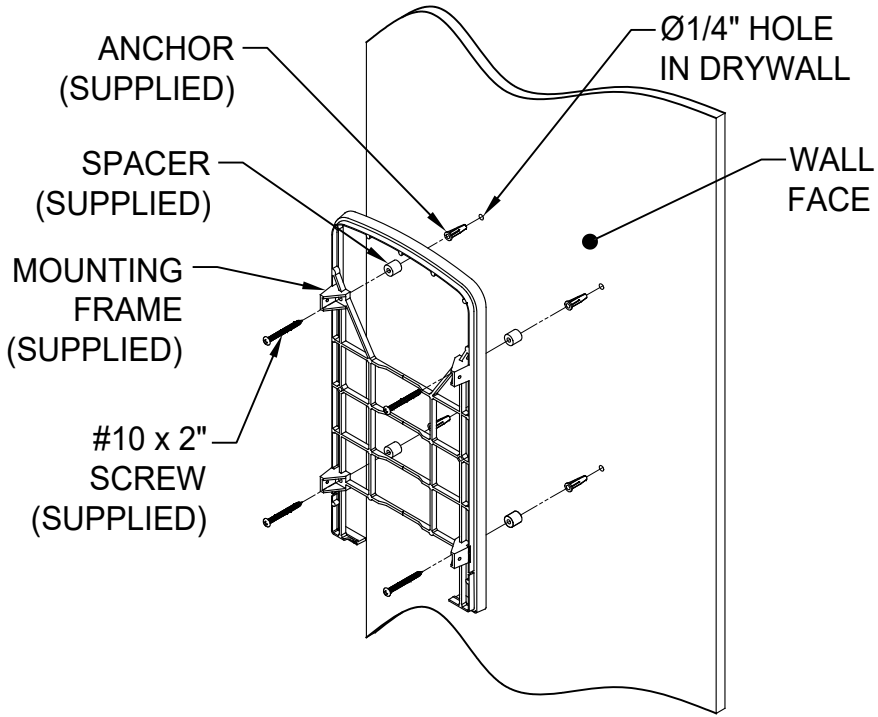

MOUNTING FASTENER DETAIL

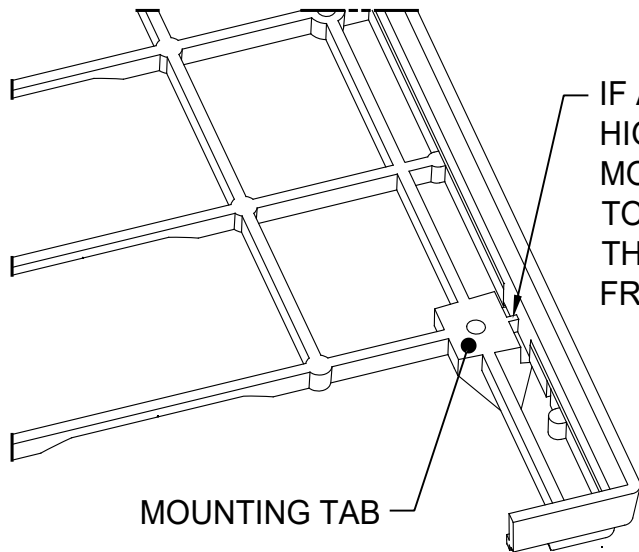

CUTTING THE MOUNTING FRAME RELIEF

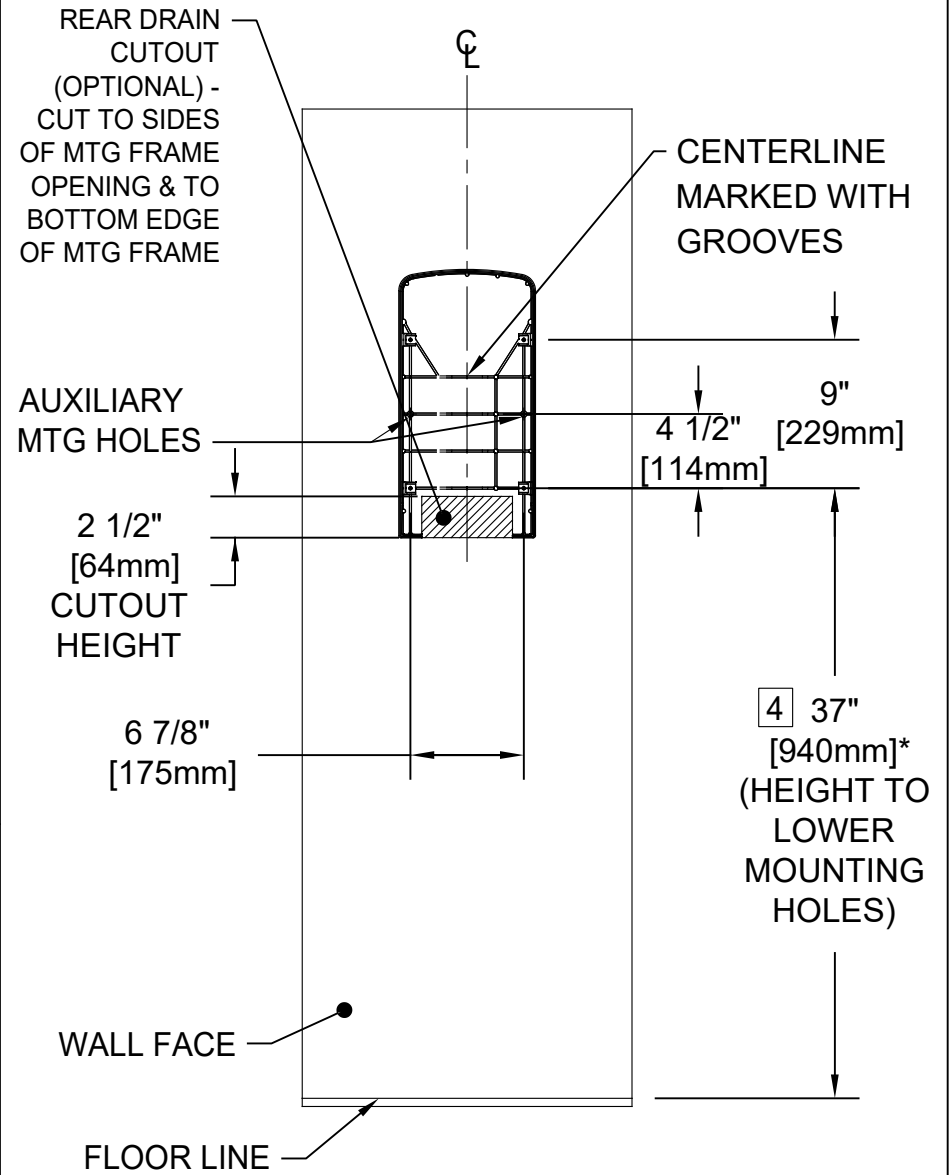

MOUNTING FRAME & OPTIONAL REAR DRAIN CUTOUT DETAILS

| | | | |
|------------|--|---|--|
| | | 1455 KLEPPE LANE SPARKS, NEVADA 89431 (775) 359-4712 FAX (775) 359-7424 E-MAIL: HAWS@HAWS.CO.COM WEBSITE: WWW.HAWS.CO.COM | |
| | | ECN NO. 4855 ECN: 5766 DRAWN: JL APPROVED: FV | REVISED PER: FV DATE: 2/10/14 DATE: 02/03/22 |
| SCALE: 1:1 | | DRAWING TYPE: INSTALLATION | SIZE: A SHEET 3 OF 4 |

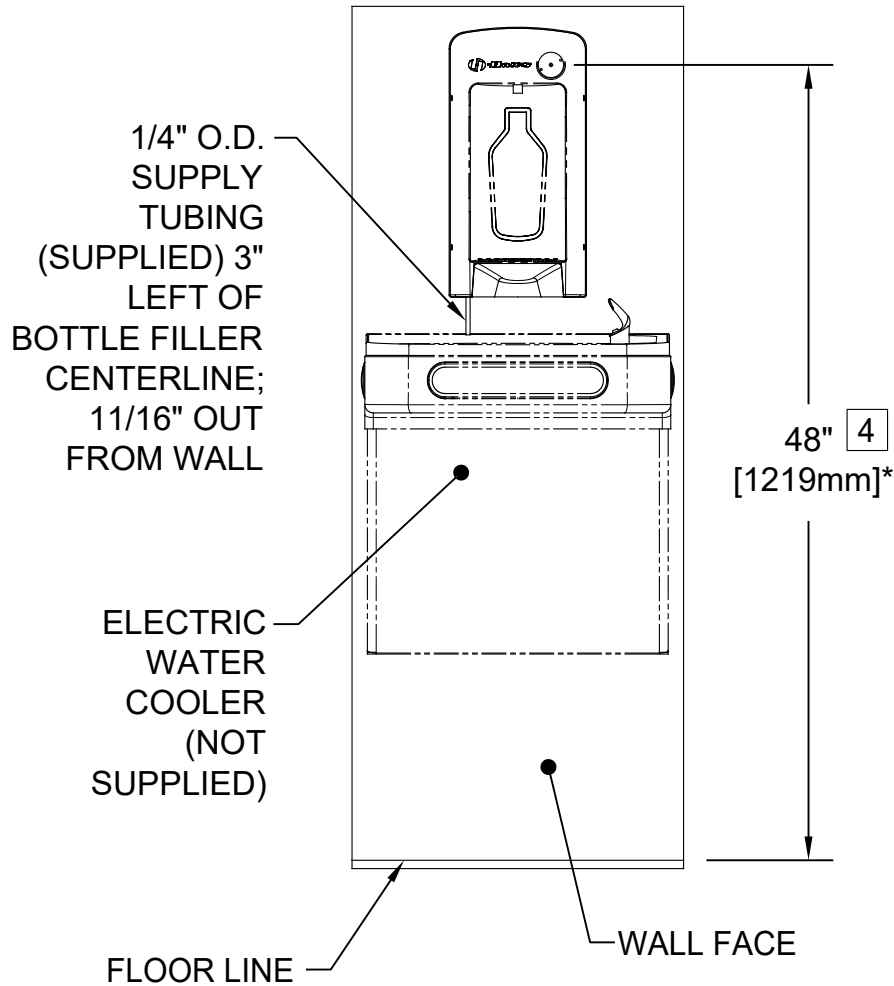

TYPICAL WATER COOLER INSTALLATION

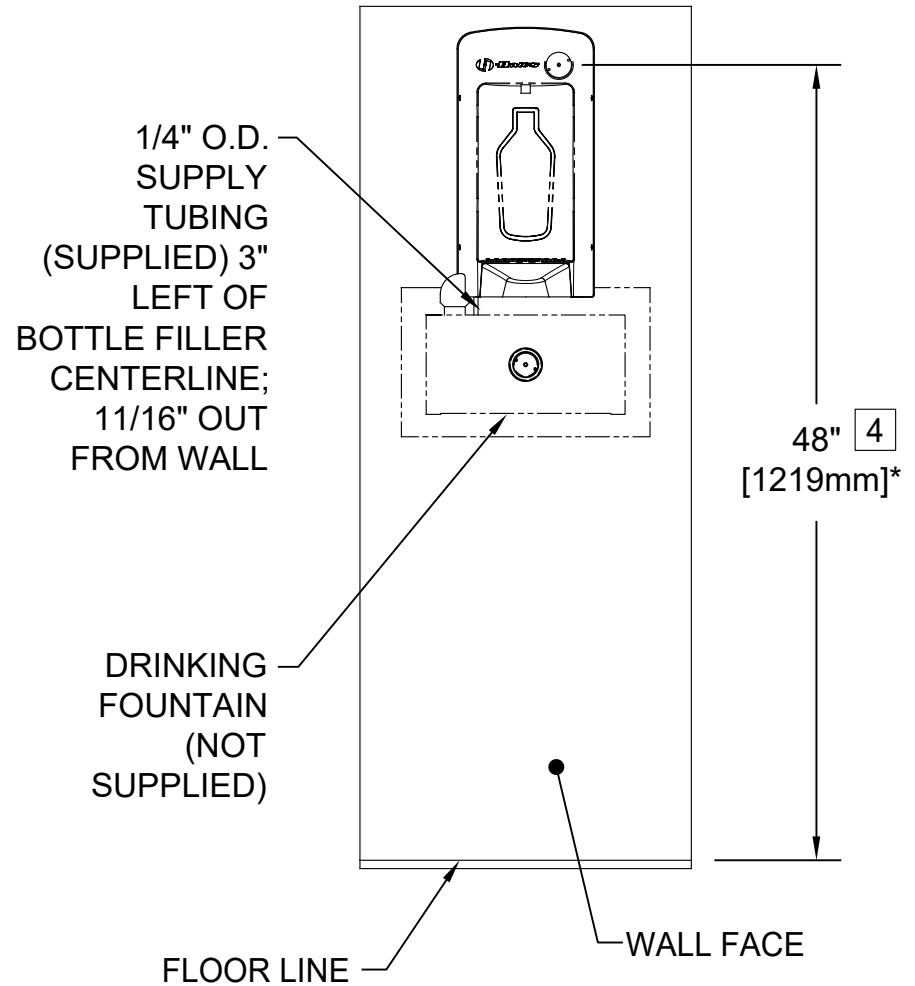

TYPICAL DRINKING FOUNTAIN INSTALLATION

| | | | |
|--------------|----------------|---|----------------------------|
| | | 1455 KLEPPE LANE SPARKS, NEVADA 89431 (775) 359-4712 FAX (775) 359-7424 E-MAIL: HAWS@HAWSCO.COM WEBSITE: WWW.HAWSCO.COM | |
| | | ECN NO. 4855 REVISED PER ECN: 5766 BY: FV | MODEL(S) 1900 |
| DRAWN: JL | DATE: 2/10/14 | CHK'D: BJM | REVISION 5 |
| APPROVED: FV | DATE: 02/03/22 | SCALE: 1:1 | DRAWING TYPE: INSTALLATION |
| SHEET 4 OF 4 | | SIZE: A | SHEET 4 OF 4 |