



model VRK01H.C

Mixing Valve Repair Kit

FEATURES & BENEFITS

OPTIONS

For more information, visit www.hawsc.com or call (888) 640-4297.



SPECIFICATIONS

The Haws VRK01H.C is a valve repair kit for the 9201H mixing valve. This kit includes parts to repair the check stops.

APPLICATIONS

KIT INSTALLATION INSTRUCTIONS

VRK01H.A: KIT, REPAIR, 9201H, COMPLETE

CONSISTS OF VRK01H.B, VRK01H.C, AND VRK01H.D. FOLLOW INSTRUCTIONS OUTLINED FOR EACH AS NOTED ON THIS PAGE.

VRK01H.B: KIT, REPAIR, 9201H, MAIN MIXING CHAMBER (REFER TO SHEET 2)

1. REMOVE 4 COVER BOLTS AND 4 WASHERS AS SHOWN.
2. REMOVE COVER.
3. REMOVE O-RING FROM COVER AND REPLACE WITH NEW O-RING FROM KIT.
4. REMOVE OVERLOAD ASSEMBLY FROM COVER BY PULLING STRAIGHT OUT, AND REPLACE WITH NEW OVERLOAD ASSEMBLY FROM KIT.
5. REMOVE PISTON/THERMOSTAT ASSEMBLY FROM VALVE BY PULLING STRAIGHT UP ON PISTON.
6. REMOVE CYLINDER ASSEMBLY FROM VALVE BY PULLING FIRMLY STRAIGHT UP ON THE CYLINDER ASSEMBLY.
7. REMOVE THREE PISTON SPRINGS FROM VALVE FUNNEL.
8. REMOVE VALVE FUNNEL FROM VALVE BY PULLING STRAIGHT UP ON FUNNEL AND FUNNEL O-RING IF IT DOES NOT COME OUT WITH THE FUNNEL.
9. INSTALL NEW FUNNEL O-RING AND FUNNEL FROM KIT.
10. INSTALL NEW CYLINDER ASSEMBLY FROM KIT AS SHOWN ON SHEET 2 BY PRESSING FIRMLY STRAIGHT DOWN AND ROCKING THE ASSEMBLY TO WORK IT PAST THE COLD INLET CHANNEL.
11. INSTALL 3 NEW PISTON SPRINGS FROM KIT INTO VALVE FUNNEL.
12. INSTALL NEW PISTON ASSEMBLY INTO CYLINDER AS SHOWN ON SHEET 2, BEING CAREFUL TO CLOCK THE PISTON SUCH THAT THE THREE FLATS UNDER THE PISTON SIT ON THE PISTON SPRINGS. THE PISTON SHOULD MOVE FREELY AGAINST THE SPRING PRESSURE IN THE CYLINDER.
13. INSTALL THE EXISTING COVER ON THE VALVE (CLOCKING IS NOT CRITICAL) AND INSERT THE FOUR COVER BOLTS AND WASHERS.
14. TIGHTEN BOLTS IN A CROSS PATTERN EVENLY UNTIL THE COVER CONTACTS THE VALVE BODY.
15. TORQUE BOLTS TO 13 FT-LBS.

VRK01H.C: KIT, REPAIR, 9201H, CHECK STOPS (REFER TO SHEET 3)

1. NOTE: HOT AND COLD CHECK STOP ASSEMBLIES ARE IDENTICAL.
2. REMOVE HOT CHECK STOP COVER WITH 1-3/8" WRENCH OR ADJUSTABLE WRENCH.
3. REMOVE SPRING, CHECK STOP ASSEMBLY, CAGE, AND MESH SCREEN FROM VALVE.
4. CLEAN ANY VISIBLE DEBRIS FROM CHECK STOP CAVITY.
5. INSTALL NEW MESH SCREEN, CAGE, AND CHECK STOP ASSEMBLY FROM KIT AS SHOWN ON SHEET 3.
6. INSTALL NEW SPRING, ADJUSTMENT SCREW, AND CHECK STOP COVER FROM KIT. ADJUSTMENT SCREW SHOULD ALWAYS BE FULLY OUT (CCW) UNLESS THERE IS A NEED TO SHUT OFF THE HOT OR COLD WATER FOR TESTING.
7. REPEAT STEPS 2-6 WITH COLD CHECK STOP ASSEMBLY.

VRK01H.D: KIT, REPAIR, 9201H, HOT SHUT OFF (REFER TO SHEET 4)

1. REMOVE HOT SHUT OFF COVER WITH 1-3/8" WRENCH OR ADJUSTABLE WRENCH.
2. REMOVE SPRING, SEAT ASSEMBLY, OVERLOAD ASSEMBLY, AND CYLINDER/THERMOSTAT ASSEMBLY FROM CAVITY BY PULLING STRAIGHT OUT. COMPONENTS CAN ALSO BE PUSHED OUT WITH A FINGER INSERTED INTO THE TEPID WATER OUTLET PORT OF THE VALVE BODY.
3. INSTALL NEW CYLINDER/THERMOSTAT ASSEMBLY, OVERLOAD ASSEMBLY, SEAT ASSEMBLY, AND SPRING FROM KIT AS SHOWN ON SHEET 4.
4. INSTALL NEW HOT SHUT OFF COVER FROM KIT AS SHOWN ON SHEET 4.

VRK01H.E: KIT, BASIC MAINT, 9201H, T-STATS+O-RINGS

1. REFER TO EXPLODED VIEWS IN SHEETS 2 - 4 AND DISASSEMBLY AND RE-ASSEMBLY INSTRUCTIONS ON THIS PAGE.
2. RECOMMEND ANY DRY O-RINGS BE LUBRICATED WITH FOOD GRADE SILICONE LUBRICANT, SUCH AS DOW CORNING 111 PRIOR TO INSTALLATION.
3. THERMOSTATS SHOULD BE INSTALLED SNUGLY, TAKING CARE NOT TO DAMAGE THEM.
4. MAIN COVER BOLTS SHOULD BE TORQUED TO 13 FT-LBS PER VRK01H.B INSTRUCTIONS.

		1455 KLEPPE LANE SPARKS, NEVADA 89431 (775) 359-4712 FAX (775) 359-7424 E-MAIL: HAWS@HAWSO.COM WEBSITE: WWW.HAWSO.COM	
ECN NO. 5405	REVISED PER ECN: 5405	BY: FV	MODEL(S)
DRAWN: DP	DATE: 04/09/19	CHKD.: FV	VRK01H.A/B/C/D/E VALVE REPAIR KITS
APPROVED: DP	DATE: 04/24/19		
		SCALE: 1:2.125	DRAWING TYPE: INSTALLATION
		SIZE: A	SHEET 1 OF 4
		PART NUMBER	0510000876
		REVISION	1

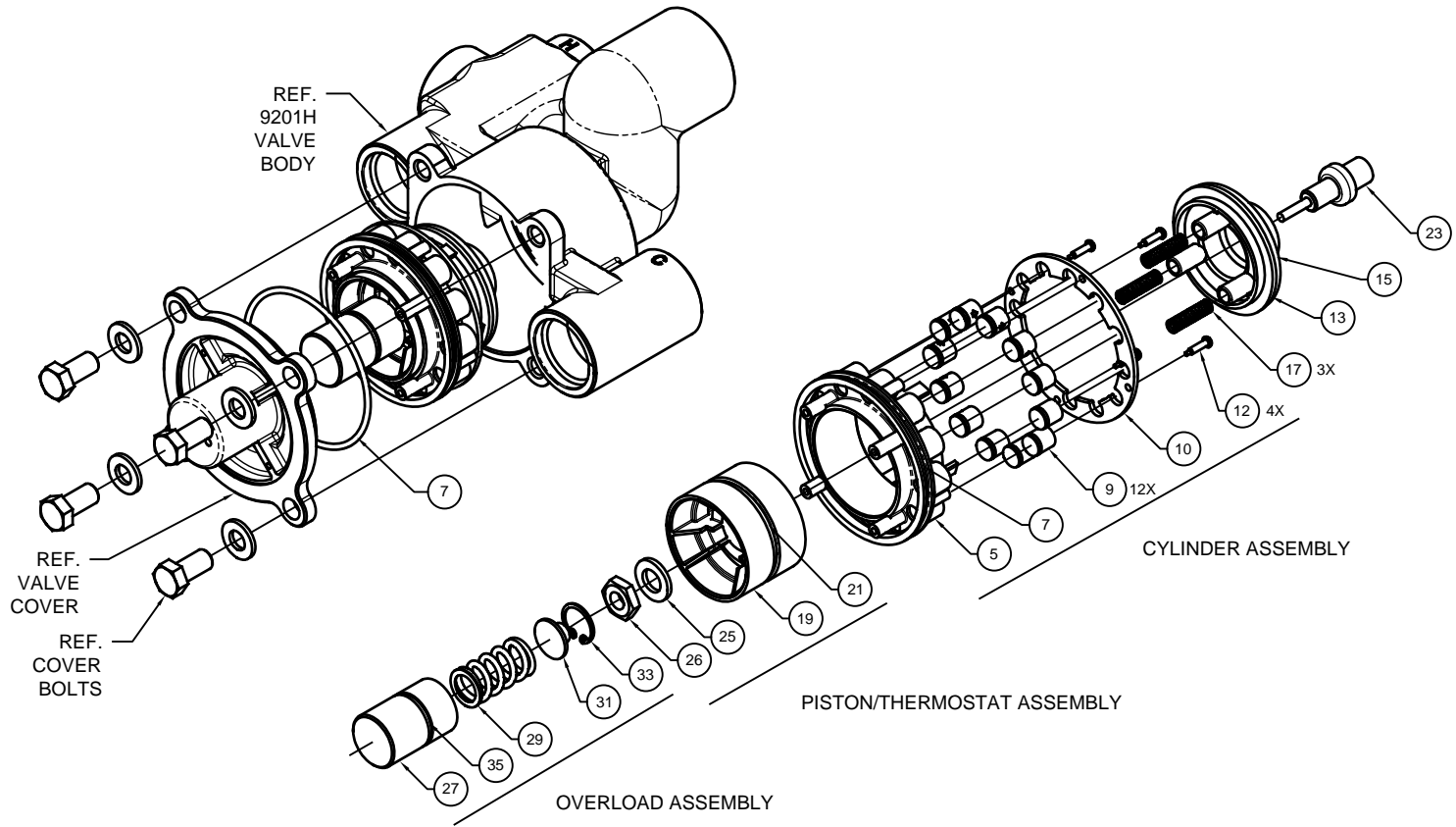

VRK01H.B MAIN MIXING CHAMBER REPAIR KIT SHOWN ON THIS SHEET

VRK01H.B MAIN MIXING CHAMBER VALVE REPAIR KIT				
ITEM #	SUB ASSEMBLY	QTY	DESCRIPTION	VRK01H.E BASIC MAINT. KIT
7	N/A	1	O-RING DASH# 150 (2.862 ID X .103 W)	INCLUDED
27	OVERLOAD ASSEMBLY	1	OVERLOAD HOUSING	
35	OVERLOAD ASSEMBLY	1	O-RING DASH# 020 (.864 ID X .070 W)	INCLUDED
29	OVERLOAD ASSEMBLY	1	OVERLOAD COMPRESSION SPRING	
31	OVERLOAD ASSEMBLY	1	OVERLOAD INSERT	
33	OVERLOAD ASSEMBLY	1	RETAINING RING	
26	PISTON/THERMOSTAT ASSY	1	JAMB NUT M10 X 1.5 SST	
25	PISTON/THERMOSTAT ASSY	1	FLAT WASHER SST	
19	PISTON/THERMOSTAT ASSY	1	PLUNGER	
21	PISTON/THERMOSTAT ASSY	1	O-RING DASH# 132 (1.737 ID X .103 W)	INCLUDED
23	PISTON/THERMOSTAT ASSY	1	THERMOSTAT MAIN 60-100	INCLUDED
5	CYLINDER ASSEMBLY	1	SLEEVE	
7	CYLINDER ASSEMBLY	1	O-RING DASH# 150 (2.862 ID X .103 W)	INCLUDED
9	CYLINDER ASSEMBLY	12	CHECK VALVE 10MM	
10	CYLINDER ASSEMBLY	1	CHECK VALVE RETAINER	
12	CYLINDER ASSEMBLY	4	SCREW #4 SST	
17	N/A	3	PISTON SPRING SST	
13	N/A	1	FUNNEL VALVE	
15	N/A	1	O-RING DASH# 329 (1.975 ID X .210 W)	INCLUDED



1455 KLEPPE LANE
SPARKS, NEVADA 89431
(775) 359-4712 FAX (775) 359-7424
E-MAIL: HAWS@HAWSCO.COM
WEBSITE: WWW.HAWSCO.COM

ECN NO. 5405	REVISED PER ECN: 5405	BY: FV	MODEL(S)	PART NUMBER
DRAWN: DP	DATE: 04/09/19	CHKD.: FV	VRK01H.A./B./C./D./E VALVE REPAIR KITS	0510000876
APPROVED: DP	DATE: 04/24/19	SCALE: N/A		DRAWING TYPE: INSTALLATION
			SIZE: A	SHEET 2 OF 4

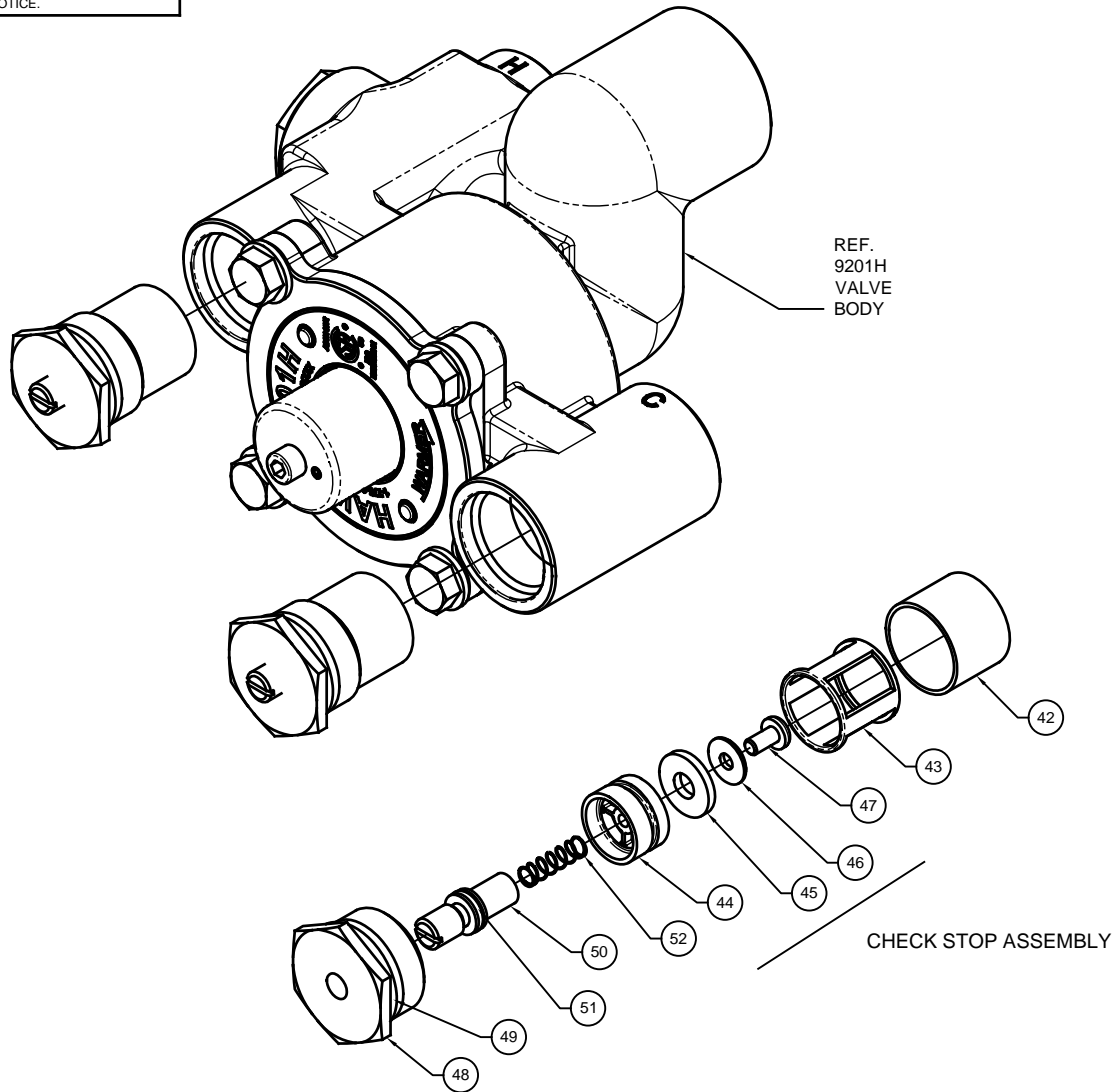

NOTE: HOT AND COLD CHECK STOPS ARE IDENTICAL. KIT INCLUDES BOTH.

**VRK01H.C CHECK STOPS REPAIR KIT
SHOWN ON THIS SHEET**

VRK01H.C CHECK STOPS REPAIR KIT				
ITEM #	SUB ASSEMBLY	QTY	DESCRIPTION	VRK01H.E BASIC MAINT. KIT
48	N/A	2	CHECK STOP COVER BONNET	
49	N/A	2	O-RING DASH# 215 (1.046 ID X .139 W)	INCLUDED
51	N/A	2	O-RING DASH# 012 (.364 ID X .070 W)	INCLUDED
50	N/A	2	STEM CHECK STOP ADJUST. SCREW	
52	N/A	2	SPRING	
44	CHECK STOP ASSY	2	POPPET (NO O-RING)	
45	CHECK STOP ASSY	2	WASHER EPDM	
46	CHECK STOP ASSY	2	WASHER SST	
47	CHECK STOP ASSY	2	SCREW SST 10-24	
43	N/A	2	CAGE SLEEVE	
42	N/A	2	MESH SCREEN SST	

		1455 KLEPPE LANE SPARKS, NEVADA 89431 (775) 359-4712 FAX (775) 359-7424 E-MAIL: HAWS@HAWS.CO.COM WEBSITE: WWW.HAWS.CO.COM	
		ECN NO. 5405 DRAWN: DP APPROVED: DP	REVISED PER: FV DATE: 04/09/19 DATE: 04/24/19
SCALE: N/A	DRAWING TYPE: INSTALLATION	SIZE: A	SHEET 3 OF 4

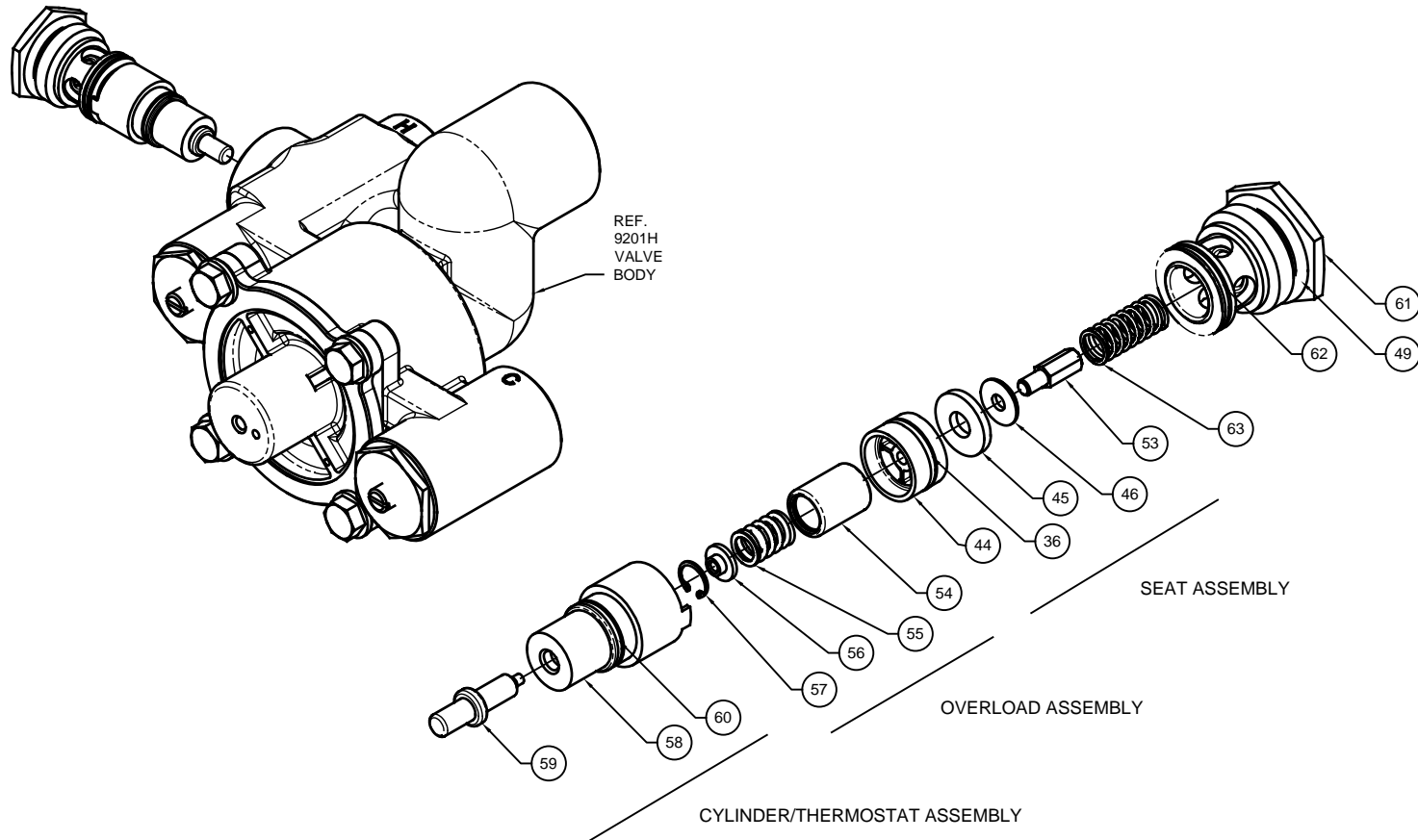

VRK01H.D HOT SHUT OFF REPAIR KIT				
ITEM #	SUB ASSEMBLY	QTY	DESCRIPTION	VRK01H.E BASIC MAINT. KIT
59	CYLINDER/THERMOSTAT ASSY	1	THERMOSTAT 90-95	INCLUDED
58	CYLINDER/THERMOSTAT ASSY	1	CYLINDER HOUSING	
60	CYLINDER/THERMOSTAT ASSY	1	O-RING DASH# 017 (.676ID X .070 W)	INCLUDED
57	OVERLOAD ASSEMBLY	1	RETAINING RING	
56	OVERLOAD ASSEMBLY	1	INSERT	
55	OVERLOAD ASSEMBLY	1	OVERLOAD COMPRESSION SPRING	
54	OVERLOAD ASSEMBLY	1	OVERLOAD HOUSING	
44	SEAT ASSEMBLY	1	POPPET	
36	SEAT ASSEMBLY	1	O-RING DASH# 018 (.739 ID X .070 W)	INCLUDED
45	SEAT ASSEMBLY	1	WASHER EPDM	
46	SEAT ASSEMBLY	1	WASHER SST	
53	SEAT ASSEMBLY	1	SPRING GUIDE	
63	N/A	1	SPRING SST	
62	N/A	1	O-RING DASH# 021 (.926 ID X .070 W)	INCLUDED
49	N/A	1	O-RING DASH# 215 (1.046 ID X .139 W)	INCLUDED
61	N/A	1	HOT SHUT OFF COVER BONNET	

**VRK01H.D HOT SHUT OFF VALVE REPAIR KIT
SHOWN ON THIS SHEET**

		Haws [®]		1455 KLEPPE LANE SPARKS, NEVADA 89431 (775) 359-4712 FAX (775) 359-7424 E-MAIL: HAWS@HAWS.CO.COM WEBSITE: WWW.HAWS.CO.COM	
				MODEL(S) VRK01H.A/B/C/D/E VALVE REPAIR KITS	
ECN NO. 5405 DRAWN: DP APPROVED: DP	REVISED PER: ECN: 5405 DATE: 04/09/19 DATE: 04/24/19	BY: FV CHKD.: FV	SCALE: N/A DRAWING TYPE: INSTALLATION	SIZE: A SHEET 4 OF 4	SHEET 4 OF 4