



model **BP15**
Back Panel

FEATURES & BENEFITS

OPTIONS

For more information, visit www.hawesco.com or call (888) 640-4297.

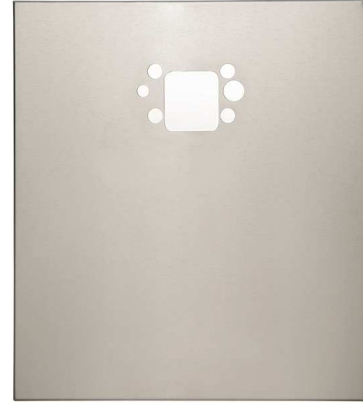

SPECIFICATIONS

Model BP15 is a versatile and decorative back panel for model 1920 that increases location visibility of the bottle filler, and also helps protect wall from inadvertent splash. This back panel is 15" x 17" (38 x 43 cm) stainless steel with a satin finish. BP15 and 1920 can be used with 1001, 1107 and 1109 series models.

APPLICATIONS

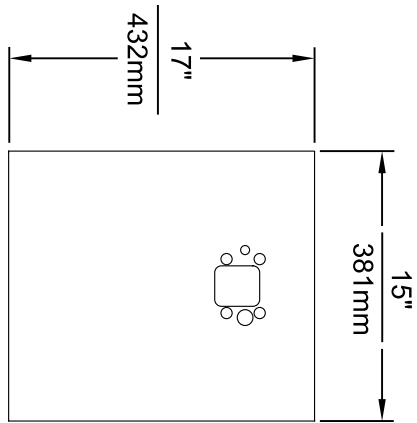

MODEL BP15 / BP15HPS / BP15W

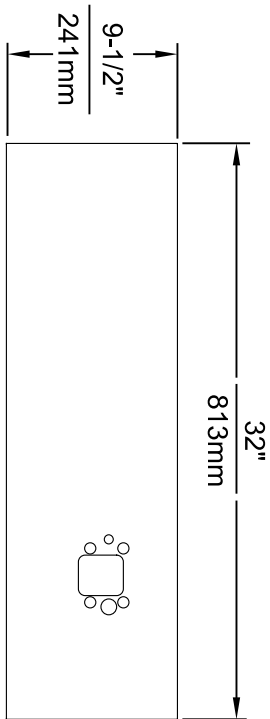
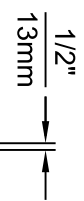

MODEL BP32 / BP32HPS / BP32W

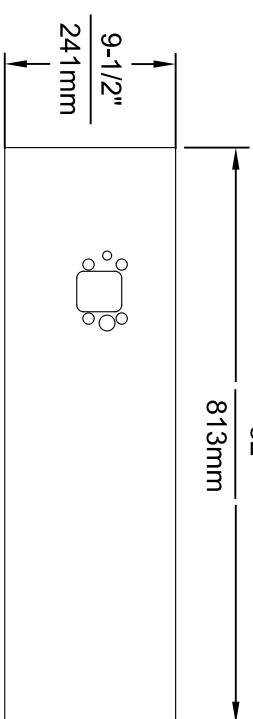
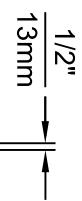

MODEL BP32R / BP32RW

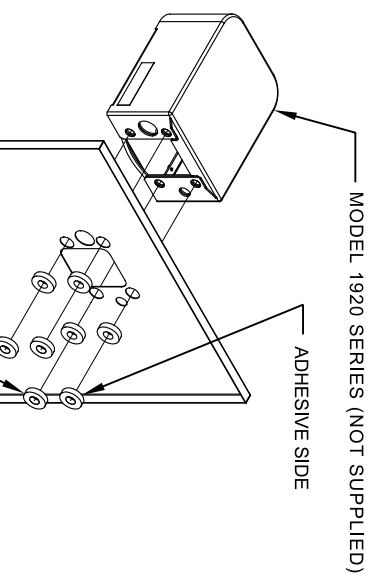
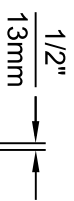

8 SPACERS (2 PER MOUNTING BOLT IF THE MOUNTING PLATE (MODEL 6700 - NOT SUPPLIED) IS INSTALLED BEHIND THE FINISHED WALL. USE 1 SPACER PER BOLT FOR RETROFITS WHERE THE MOUNTING PLATE (MODEL 6700R - NOT SUPPLIED) IS INSTALLED IN FRONT OF THE FINISHED WALL)

INSTALLATION OVER SINGLE FOUNTAIN

SHOWN FROM REAR
 (SEE SHEET 3 OF 3 FOR INSTALLATION OF SPACERS ON COMBINATION BOTTLE FILLER AND FOUNTAIN BACK PANELS FOR CHILD HEIGHT APPLICATIONS - MODELS BP15C & BP15WC)

- NOTES:
1. WHEN INSTALLING THIS UNIT, LOCAL, STATE OR FEDERAL CODES SHOULD BE ADHERED TO.
 2. BOTTLE FILLER SHOWN FOR REFERENCE ONLY (NOT SUPPLIED).

 <p>Haws Since 1906</p>		MODEL(S) DRAWING, BACK PANEL, SPACER INSTALLATION FOR BP15 SERIES & BP32 SERIES, BOTTLE FILLER	PART NUMBER 0510000493
EGN NO. REVISED PER BY: 5081 EGN: 5972 FV	DATE: 08/27/16 JC	SCALE: 1"=1"	REVISION: 5
DRAWN: M.J.	CHECKED: JC	DRAWING TYPE: INSTALLATION	SIZE: A1 SHEET: 1 OF 3
APPROVED: FV	DATE: 04/19/24	INSTALLATION	1455 KLEPPLELANE SPARKS, NEVADA 89431 (775) 359-4712 FAX (775) 359-7424 E-MAIL: HAWS@HAWS.CO.COM WEBSITE: WWW.HAWS.CO.COM

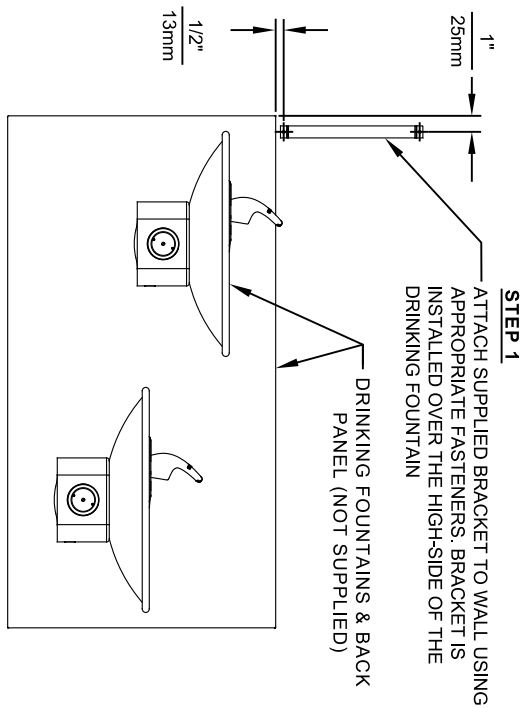

STEP 2
PLACE THE BACKPLATE AGAINST THE WALL AND SLIDE SIDEWAYS SO THE TABS CATCH UNDER THE BRACKET.

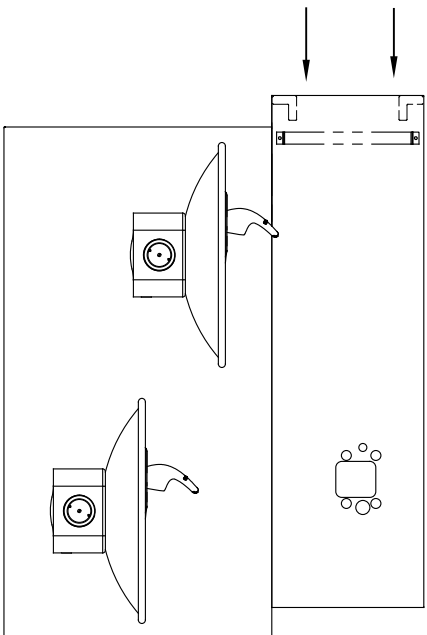

STEP 3
INSTALL THE BOTTLE FILLER (NOT SUPPLIED) PER THE INSTRUCTIONS SUPPLIED WITH THE UNIT.

NOTES:
1. WHEN INSTALLING THIS UNIT, LOCAL, STATE OR FEDERAL CODES SHOULD BE ADHERED TO.

2. BOTTLE FILLERS, DRINKING FOUNTAINS & DRINKING FOUNTAIN BACK PANELS SHOWN FOR REFERENCE ONLY (NOT SUPPLIED).

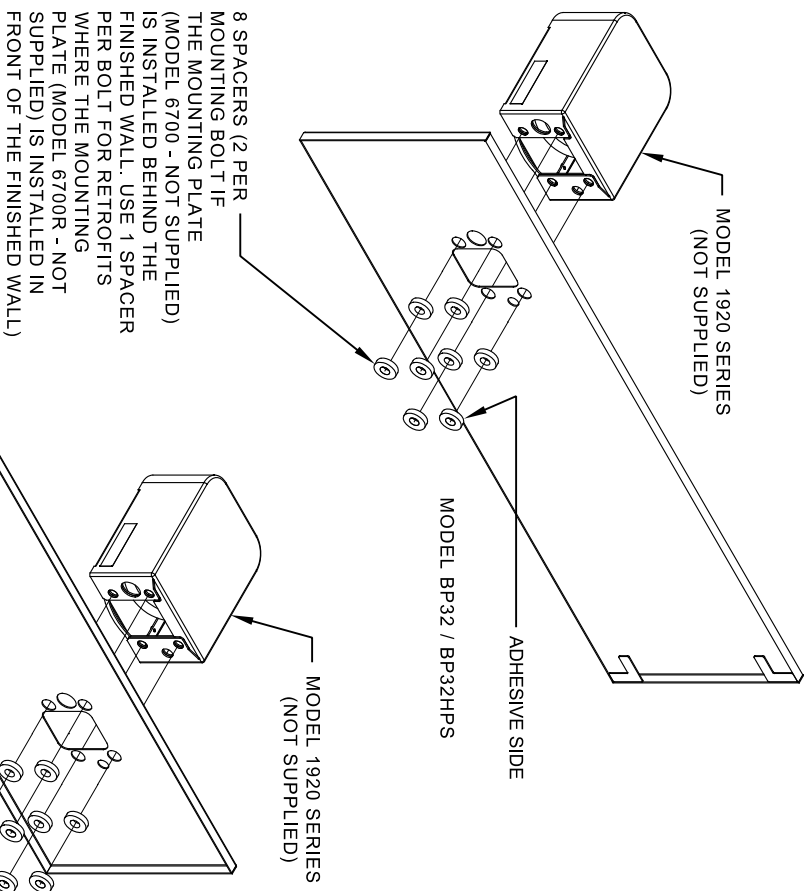

INSTALLATION OVER DOUBLE FOUNTAIN SHOWN FROM REAR

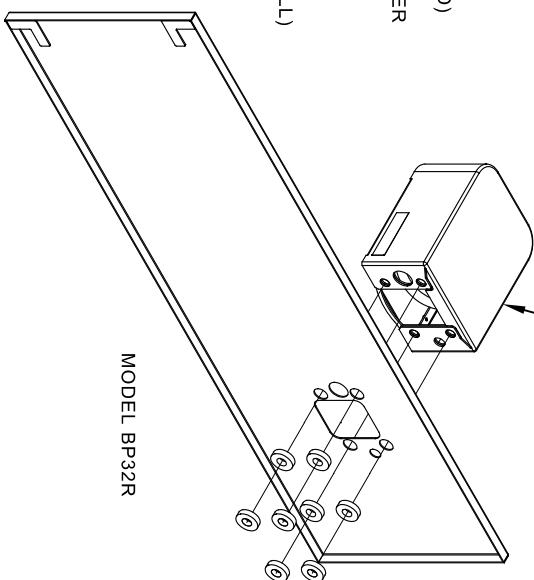

EQUIPMENT		DRAWING		SCALE		REVISION	
NO.	REVISED PER BY:	NO.	DATE	DATE	DATE	NO.	DATE
5081	FV	5081	02/02/17	02/02/17	02/02/17	5	05/10/000493
DATE	DATE	DATE	DATE	DATE	DATE	DATE	DATE
04/19/24	04/19/24	04/19/24	04/19/24	04/19/24	04/19/24	04/19/24	04/19/24
DRAWING		SCALE		DRAWING TYPE		SHEET	
MODEL(S)		1:1		INSTALLATION		2 OF 3	
DRAWING, BACK PANEL, SPACER INSTALLATION FOR BP15 SERIES & BP32 SERIES, BOTTLE FILLER							
 Haws Since 1906		1455 KLEPPLELANE SPARKS, NEVADA 89431 (775) 359-4712 FAX (775) 359-7424 E-MAIL: HAWS@HAWSCO.COM WEBSITE: WWW.HAWSCO.COM		PART NUMBER 0510000493		REVISION 5	

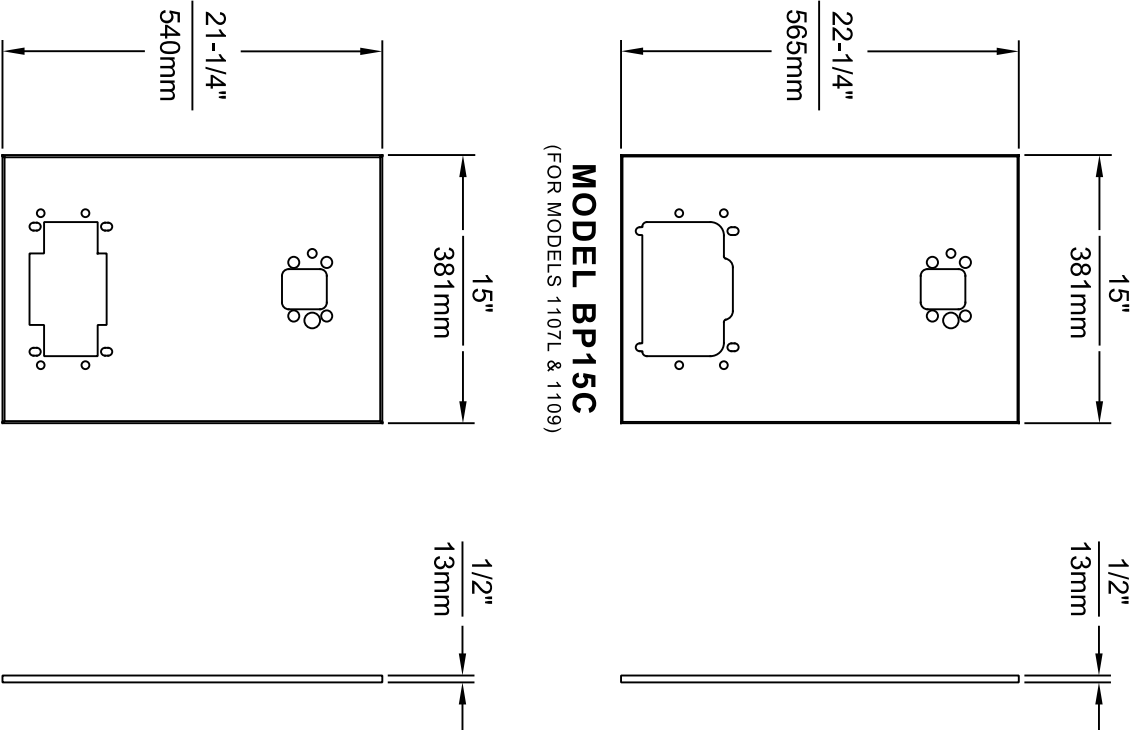

MODEL BP15WC
(FOR MODEL 1311)

MODEL BP15C
(FOR MODELS 1107L & 1109)

- NOTES:
1. WHEN INSTALLING THIS UNIT, LOCAL, STATE OR FEDERAL CODES SHOULD BE ADHERED TO.
 2. BOTTLE FILLER AND DRINKING FOUNTAIN SHOWN FOR REFERENCE ONLY (NOT SUPPLIED).

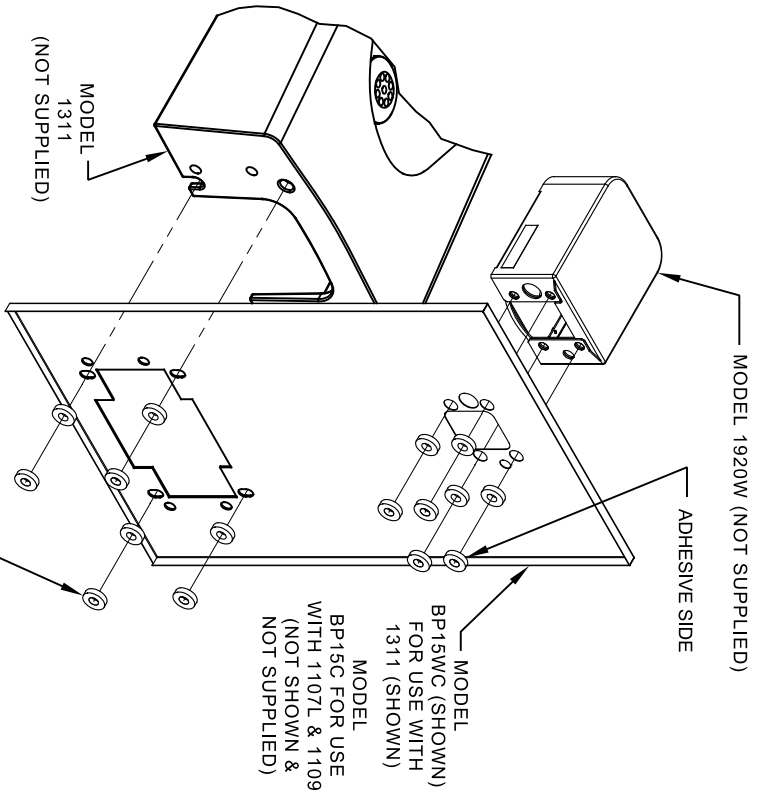

16 SPACERS (2 PER MOUNTING BOLT IF BOTH MOUNTING PLATES (MODEL 6700 - NOT SUPPLIED) ARE INSTALLED BEHIND THE FINISHED WALL. USE 1 SPACER PER BOLT FOR RETROFITS WHERE BOTH MOUNTING PLATES (MODEL 6700R - NOT SUPPLIED) ARE INSTALLED IN FRONT OF THE FINISHED WALL)

ONE PIECE INSTALLATION ON SINGLE FOUNTAIN

SHOWN FROM REAR
(MODEL BP15C & BP15WC ARE COMBINATION BOTTLE FILLER AND FOUNTAIN BACK PANELS USED FOR CHILD HEIGHT APPLICATIONS ONLY ON MODELS 1107L, 1109 & 1311 - BOTTLE FILLER & DRINKING FOUNTAIN NOT SUPPLIED)

<p>Haws Since 1906</p>		<p>1455 KLEPPLELANE SPARKS, NEVADA 89431 (775) 359-4712 FAX (775) 359-4424 E-MAIL: HAWS@HAWSCO.COM WEBSITE: WWW.HAWSCO.COM</p>	
<p>EGN NO. 5972 DRAWN: FV DATE: 12/19/23</p>	<p>REVISED PER BY: FV ECON: 5972 DATE: 12/19/23</p>	<p>MODEL(S) DRAWING, BACK PANEL, SPACER INSTALLATION FOR BP15 SERIES & BP32 SERIES, BOTTLE FILLER</p>	<p>PART NUMBER: 0510000493 REVISION: 5</p>
<p>APPROVED: FV DATE: 04/19/24</p>	<p>SCALE: 1:1</p>	<p>DRAWING TYPE: INSTALLATION</p>	<p>SIZE: A1 SHEET 3 OF 3</p>