

FEATURES & BENEFITS

OPTIONS

For more information, visit www.hawesco.com or call (888) 640-4297.



SPECIFICATIONS

Model 8317LT is a vapor tight and gasketed green light for continuous illumination of the 8317CTFP series showers. Model is CSA electrical certified, TYPE 4. For Class 1, Div. 2, Group B, C & D. Temperature Code: T2C; only when used with 8317CTFP.

APPLICATIONS

Model is CSA electrical certified, TYPE 4. For Class 1, Div. 2, Group B, C & D. Temperature Code: T2C; only when used with 8317CTFP.



NOTES:

1. INSTALLER MUST USE SUFFICIENT THREAD SEALANT, SUCH AS APPLETON TLC-3, RECOMMENDED FOR USE IN HAZARDOUS LOCATIONS, TO ENSURE A WATERTIGHT SEAL ON ALL ELECTRICAL NPT CONNECTIONS.

(CONTINUED ON SHEET 2)

SEE WARNINGS ON SHEET 2

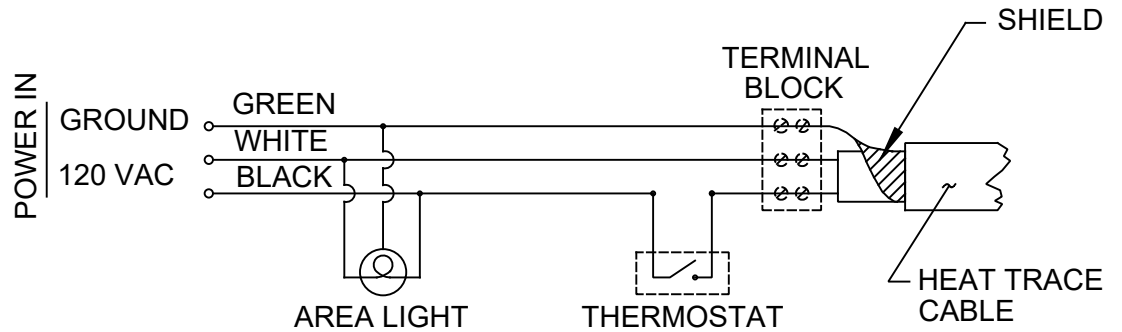

8317LT (LIGHT KIT INSTALLATION)

INCOMING POWER TO TOP PORT OF JUNCTION BOX (NOT SUPPLIED)

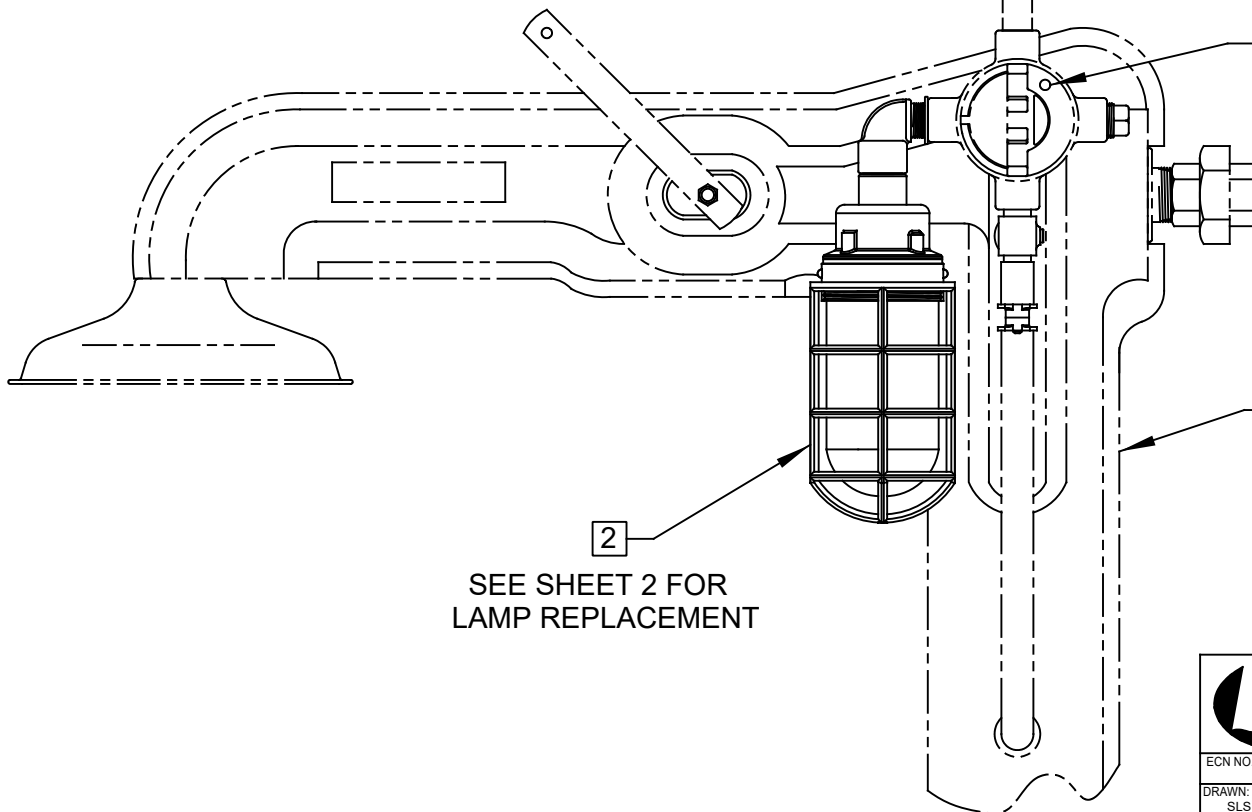

AMBIENT SENSING THERMOSTAT ON 8317CTFP SERIES (NOT SUPPLIED)

SHOWER SHOWN FOR REFERENCE ONLY (NOT SUPPLIED)

SEE SHEET 2 FOR LAMP REPLACEMENT

		Haws		1455 KLEPPE LANE SPARKS, NEVADA 89431 (775) 359-4712 FAX (775) 359-7424 E-MAIL: HAWS@HAWS.CO.COM WEBSITE: WWW.HAWS.CO.COM	
ECN NO.	REVISED PER	BY:	MODEL(S)	PART NUMBER	
	ECN: 5775	FV	8317LT	0002080156	
DRAWN:	DATE:	CHK'D:		REVISION	
SLS	07-09	JS		5	
APPROVED:	DATE:	SCALE:	DRAWING TYPE:	SIZE:	SHEET
FV	02/22/22	1:1	INSTALLATION	A	1 OF 2

NOTES: (CONTINUED FROM SHEET 1)

2 LIGHT BULB REPLACEMENT INSTRUCTIONS:

- 1) REMOVE GUARD AND GLOBE:
FIRST LOOSEN SET SCREW (LOCATED ON GUARD WHERE SHOWN). NEXT, ROTATE GUARD COUNTER CLOCKWISE UNTIL GUARD IS FREE. FINALLY ROTATE GLOBE COUNTER CLOCKWISE UNTIL GLOBE IS FREE AND LAMP IS EXPOSED.
- 2) REPLACE LAMP WITH HAWS P/N 0003225495.
WARNING - EXPLOSION HAZARD - SUBSTITUTION OF COMPONENTS MAY IMPAIR SUITABILITY FOR CLASS 1, DIVISION 2.
- 3) REPLACE GUARD AND GLOBE:
ROTATE GLOBE CLOCKWISE ONTO THREADS UNTIL SEALED AGAINST GASKET. NEXT, ROTATE GUARD CLOCKWISE ONTO THREADS UNTIL TIGHT. FINALLY TIGHTEN SET SCREW.
- 4) **WARNING: WHEN INSTALLED ON 8317CTFP, THE ASSEMBLY IS ONLY RATED FOR T2C.**
- 5) ALL INSTALLATIONS MUST BE INSTALLED IN COMPLIANCE WITH LOCAL, STATE, AND/OR FEDERAL CODES.

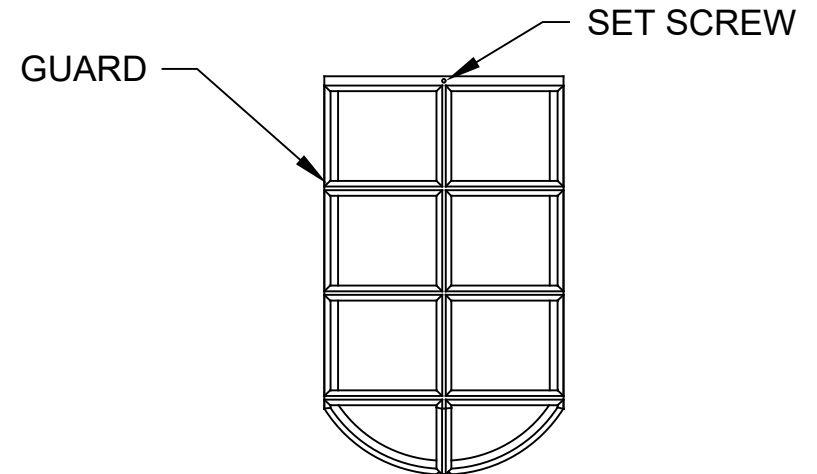
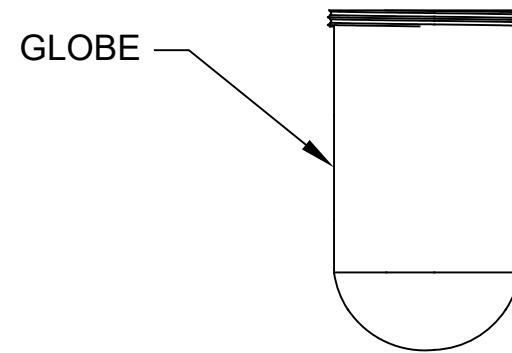
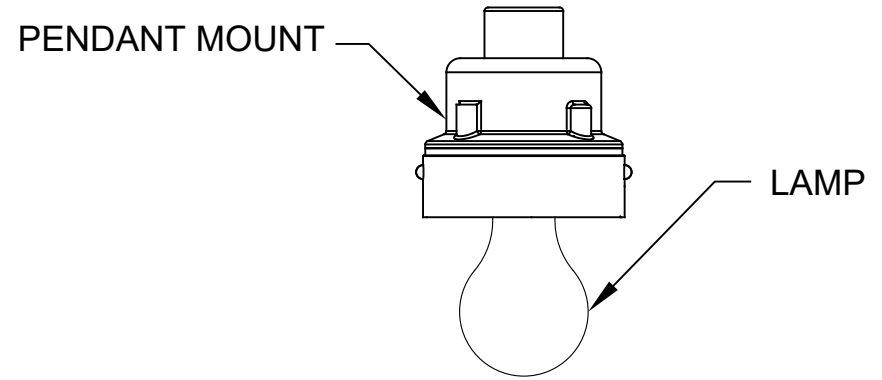

 Haws [®]		1455 KLEPPE LANE SPARKS, NEVADA 89431 (775) 359-4712 FAX (775) 359-7424 E-MAIL: HAWS@HAWSKO.COM WEBSITE: WWW.HAWSKO.COM		
		ECN NO. REVISED PER BY: MODEL(S) ECN: 5775 FV	8317LT	
DRAWN: FV DATE: 07-09 CHK'D: JS	DATE: 02/22/22	SCALE: 1:1	DRAWING TYPE: INSTALLATION	REVISION 5
APPROVED: FV	DATE: 02/22/22	SCALE: 1:1	DRAWING TYPE: INSTALLATION	SIZE: A SHEET 2 OF 2