

## FEATURES & BENEFITS

### SHOWERHEAD

AXION® MSR stainless steel showerhead uses a hydrodynamic design to give equal distribution of water throughout the entire footprint of flow.

### BALL VALVE

Brass stay-open ball valve is designed so the full flow of water remains on with the simple tug of a pull down lever. Unit also comes equipped with a stainless steel ball and stem to provide added protection against corrosion and breakage.

### QUALITY CONTROL

Valve assembly is pre-built for reduced installation time and an added peace of mind for the installer.

### PULL ROD

Pull down lever is mounted within a recessed stainless steel wall cabinet for easy locating while providing a finished look.

### SAFETY

8" x 10-3/4" (20.3 x 27.3 cm) universal emergency sign make the unit easily detected in an emergency. Test card to record weekly checks helps maintain the units best working quality.



## OPTIONS

- Scald Protect Bleed Valve: Model SP157A, stainless steel scald protection bleed valve. Automatic thermal actuator bleed valve opens when internal water temperature reaches 98° F (36.7° C) and closes at 95° F (35° C).
- Thermostatic Mixing Valve: Model 9201E AXION® Emergency Tempering Valve thermostatically mixes hot and cold water to provide a safe fluid supply for emergency showers and eyewash equipment, with a flow rate of 31 gpm (117.3 L).
- Emergency Alarm System: Model 9001, 1-1/4" 120 VAC emergency alarm and light system. Buzzer and flashing light are activated by an 1-1/4" double pole, double throw flow switch.
- Thermostatic Mixing Valve: Model 9201H Lead-free AXION® Emergency Tempering Valve thermostatically mixes hot and cold water to provide a safe fluid supply for emergency showers and eyewash equipment, with a flow rate of 31 gpm (117.3 L).

For more information, visit [www.hawsco.com](http://www.hawsco.com) or call (888) 640-4297.

## SPECIFICATIONS

Model 8164 flush ceiling mounted drench shower shall include the AXION® MSR hydrodynamic design polished stainless steel showerhead with 20 gpm flow control mounted in or hanging down from the ceiling, brass stay-open ball valve equipped with stainless steel ball and stem, recessed stainless steel wall cabinet with pull down lever, universal sign, and 1" NPT supply.

## APPLICATIONS

Where the body of any person may be exposed to injurious or corrosive materials, suitable facilities for quick drenching or cleansing of the body shall be provided within the work area for immediate emergency use. Emergency eyewash facilities and deluge showers shall be in unobstructed and accessible locations that require no more than 10 seconds for the injured person to reach. Model 8164 is certified by CSA to meet the ANSI/ISEA Z358.1 Standard for Emergency Eyewash and Shower Equipment.



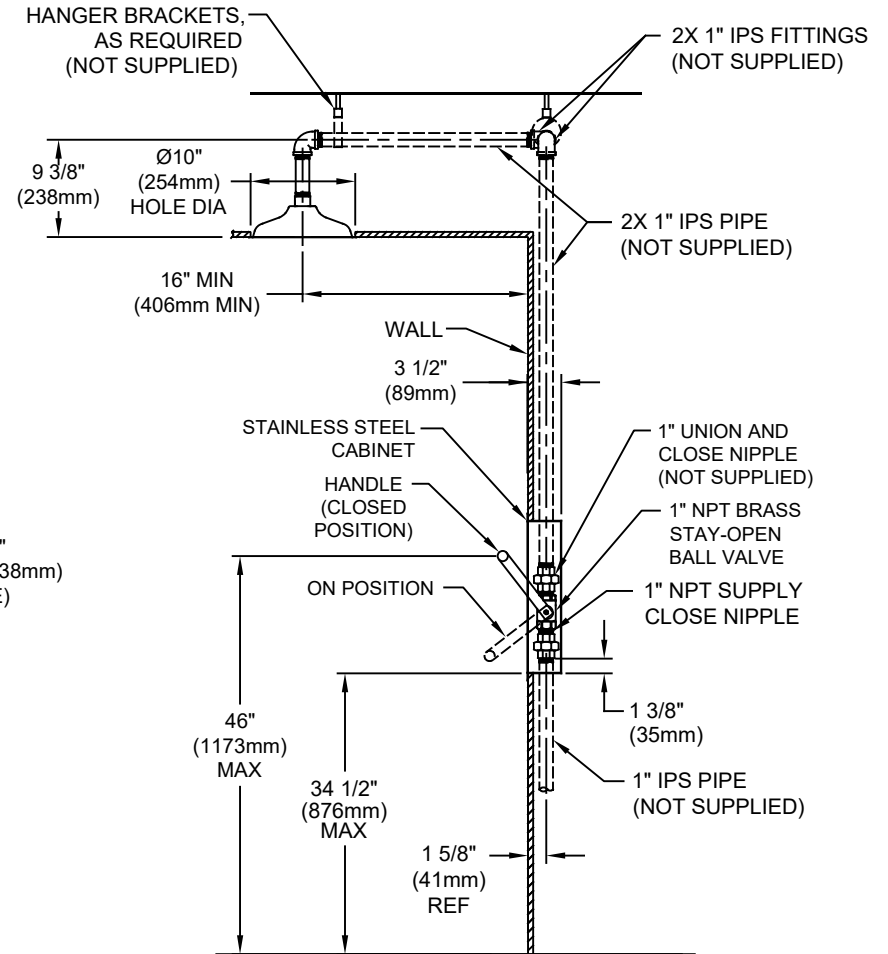
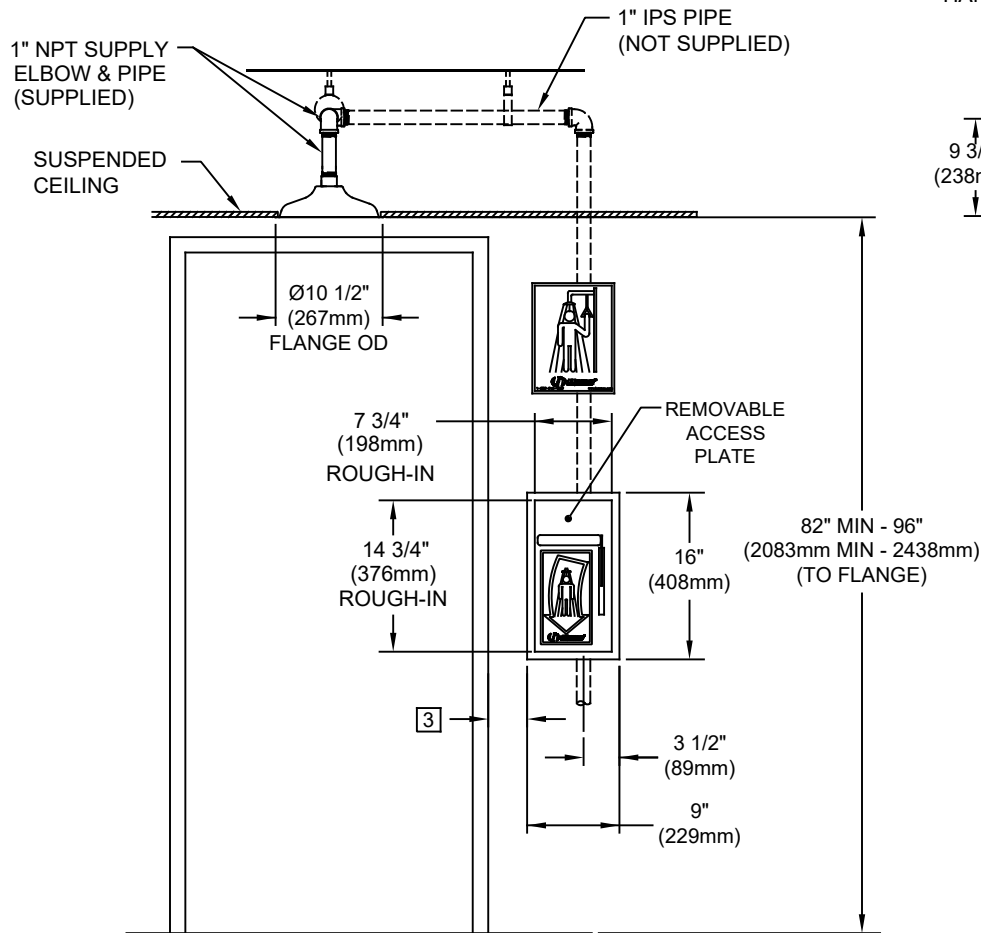

NOTES:

1. WHEN INSTALLING THIS UNIT, LOCAL, STATE, OR FEDERAL CODES SHOULD BE ADHERED TO FOR INSTALLATION DIMENSIONS (LOCATIONS), WASTE AND SUPPLY REQUIREMENTS OTHER THAN SHOWN.
2. TO COMPLY WITH ANSI Z358.1-2014 FOR EMERGENCY SHOWER EQUIPMENT:
  - SHOWER SHALL BE POSITIONED SUCH THAT SHOWER HEAD IS NO LESS THAN 82" (2083mm) AND NO GREATER THAN 96" (2438mm) FROM SURFACE ON WHICH USER STANDS.
  - SHOWER SPRAY PATTERN SHALL HAVE A MINIMUM DIAMETER OF 20" (508mm) AT 60" (1524mm) ABOVE SURFACE ON WHICH USER STANDS, AND CENTER OF SPRAY PATTERN SHALL BE LOCATED NO LESS THAN 16" (406mm) FROM NEAREST OBSTRUCTION.

3] INSTALL STAINLESS STEEL CABINET AS CLOSE TO DOOR JAM AS POSSIBLE.

4. DIMENSIONS MAY VARY BY ±1/2" (13 mm).

(NOTES CONTINUED ON SHEET 2.)

**SEE SHEET 2 FOR ALTERNATE "HANG DOWN" INSTALLATION**

		<b>Haws®</b>		1455 KLEPPE LANE SPARKS, NEVADA 89431 (775) 359-4712 FAX (775) 359-7424 E-MAIL: HAWS@HAWS.CO.COM WEBSITE: WWW.HAWS.CO.COM	
				ECN NO. REVISED PER BY: MODEL(S) ECN: 5725 FV	8164
DRAWN: DO DATE: 3/9/00	CHECKED: DP DATE:	APPROVED: FV DATE: 09/23/21	SCALE: NA	DRAWING TYPE: INSTALLATION	SIZE: A
SHEET 1 OF 2					REVISION 16

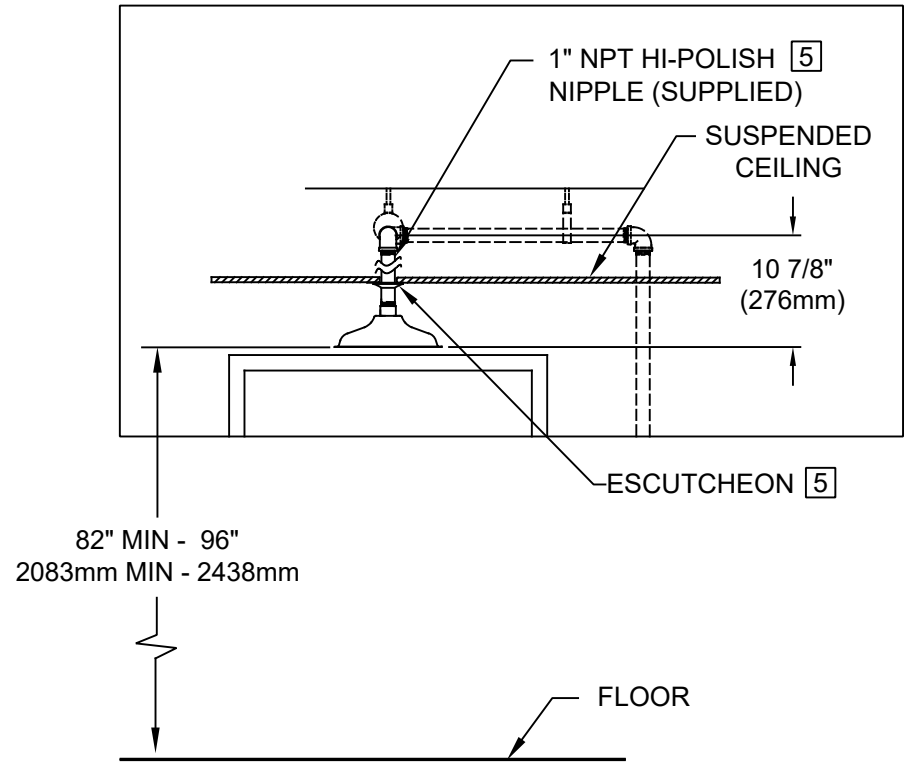
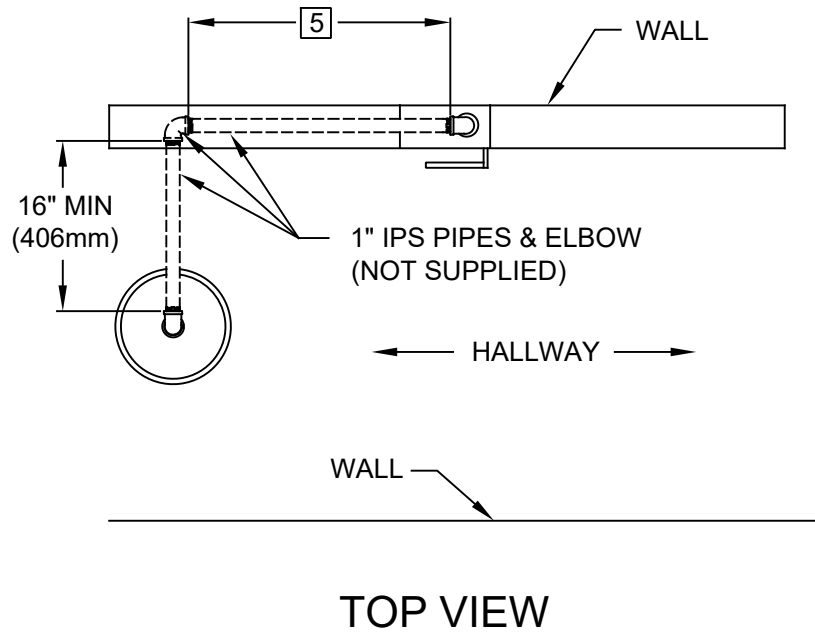

5 ALTERNATE "HANG DOWN" INSTALLATION

NOTES: (CONTINUED FROM SHEET 1)

- 5 FOR ALTERNATE "HANG DOWN" INSTALLATION OF SHOWER HEAD PERFORM THE FOLLOWING STEPS:  
 A) SWAP NIPPLE, 1" NPT X 5" LONG, FOR NIPPLE, HI-POLISH, 1" NPT X 6 1/2" LONG (SUPPLIED).  
 B) USE CEILING ESCUTCHEON FOR 1" NPT PIPE.

		1455 KLEPPE LANE SPARKS, NEVADA 89431 (775) 359-4712 FAX (775) 359-7424 E-MAIL: HAWS@HAWSCO.COM WEBSITE: WWW.HAWSCO.COM	
ECN NO.	REVISED PER	BY:	MODEL(S)
	ECN: 5725	FV	
DRAWN:	DATE:	CHK'D:	
DO	3/9/00	DP	8164
APPROVED:	DATE:		
FV	09/23/21		
SCALE: NA		DRAWING TYPE: INSTALLATION	SIZE: A
PART NUMBER			REVISION
0002080138.D			16
SHEET 2 OF 2			