

## FEATURES & BENEFITS

### MOUNTING

Reliable and fully engineered system allows for the pneumatic valve and waste assembly mounted within an insulated galvanized steel box to be installed in a heated wall space allowing the mating drinking fountain to be used year round without freezing.

### FLOW REGULATION

The valve system is furnished with automatic .4 gpm (1.5 L) stream regulation.

## OPTIONS

For more information, visit [www.hawsc.com](http://www.hawsc.com) or call (888) 640-4297.



## SPECIFICATIONS

Model 6521FR freeze-resistant valve system for use with single bubbler wall mounted fountains shall include a brass pneumatic operated valve, waste assembly designed to drain water left in supply line to fountain, regulator valve to control stream height, insulated galvanized steel mounting box installed on interior wall where temperatures maintain a minimum of 50° F (10° C), 1/2" NPT supply, and 1-1/4" NPT trap.

## APPLICATIONS

Freeze-resistant valve system is used in all Haws single bubbler, freeze-resistant, wall mounted fountains. Designed to be mounted in a setting with a minimum of 50° F, this valve system allows the fountain it is installed with to function year round in freezing conditions. Responsible for this non-freezing feat is a pneumatic operated valve and waste assembly. Unit drains the left over water in the supply line back into the temperature regulated waste cabinet for removal. Haws manufactures drinking fountains, faucets and electric water coolers to be lead-free by all known definitions including NSF/ANSI/CAN 61- Section 9, NSF/ANSI/CAN 372, California Proposition 65, and the Federal Safe Drinking Water Act. Product is compliant to California Health and Safety Code 116875 (AB 1953-2006), and NSF/ANSI/CAN 61: Q ≤ 1.



**NOTES:**

1. UNIT MAY BE RECESSED MOUNTED IN WALL AS SHOWN IN VIEW "C" OR SURFACE MOUNTED AS SHOWN IN VIEWS "A" AND "B".
2. VALVE MUST BE INSTALLED IN SPACE THAT MAINTAINS A MINIMUM OF 50°F (10°C).
3. DRINKING FOUNTAIN AND BOTTLE FILLER MODELS 1109FR & 1920FR EACH REQUIRE A SEPARATE 6521FR UNIT. DUAL DRINKING FOUNTAIN MODEL 1119FR REQUIRES TWO SEPARATE 6521FR UNITS. THE MODELS LISTED HERE ARE AVAILABLE SEPARATELY OR AS PART OF PRODUCT BUNDLES.

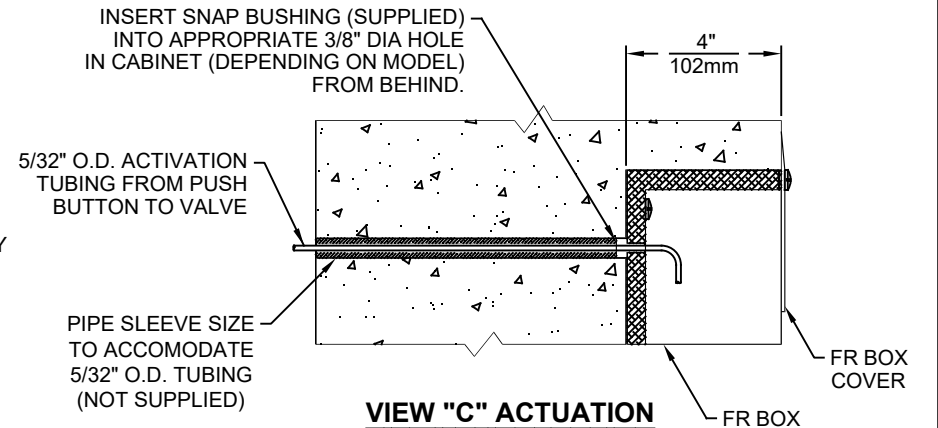
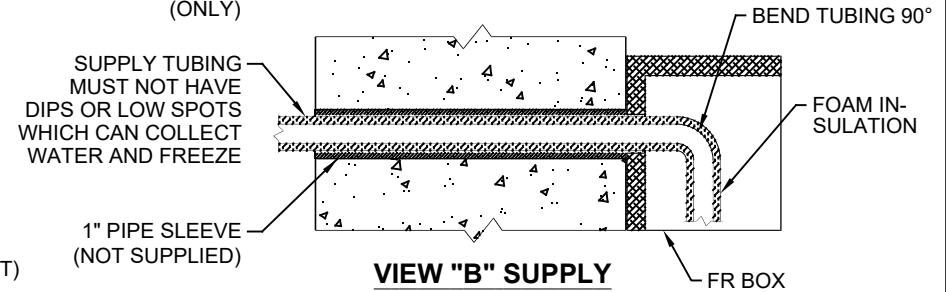
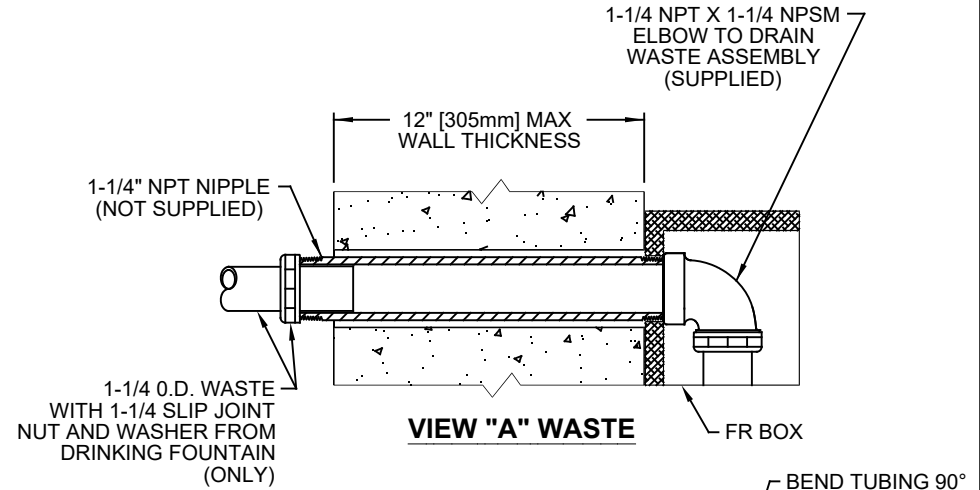
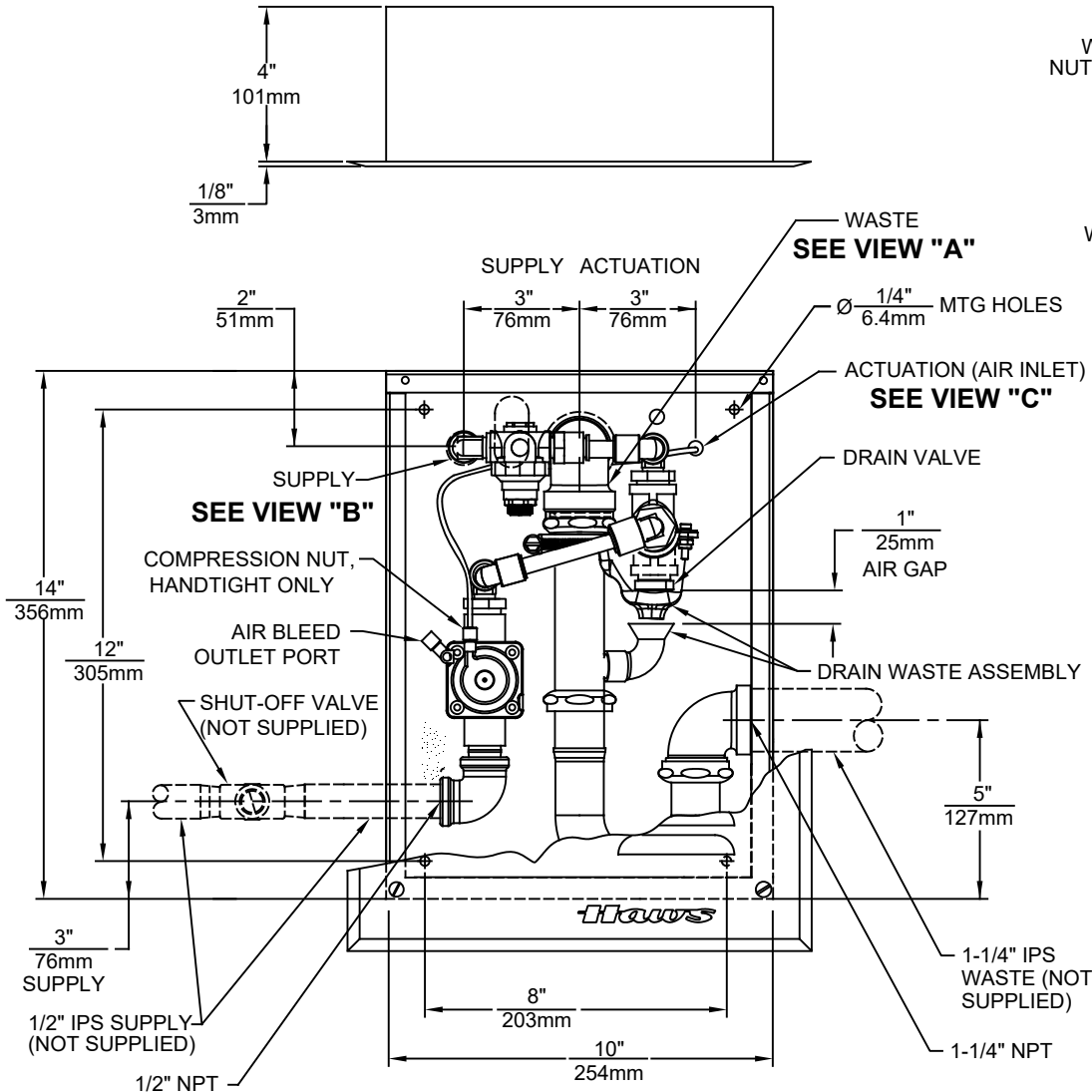



**Haws**

1455 KLEPPE LANE  
 SPARKS, NEVADA 89431  
 (775) 359-4712 FAX (755) 359-7424  
 E-MAIL: HAWS@HAWSCO.COM  
 WEBSITE: WWW.HAWSCO.COM

ECN NO:	REVISED PER:	BY:	MODEL(S)	PART NUMBER
CJL	ECN: 5799	JS	6521FR	0002077820.D
DATE:	DATE:	CHK'D:		DRAWING NO.
09/92	09/92			09306A00
APPROVED:	DATE:	SCALE:	DRAWING TYPE:	SHEET 1 OF 1
FV	07/08/22	1:5	INSTALLATION	18