



model **6475**  
Custom Logo Panel

## FEATURES & BENEFITS

### CUSTOM LOGO PANEL

Personalize your new or existing fountain or bottle filler where space permits with an optional customizable 10" high by 4.25" wide stainless steel panel. Virtually any company logo, event logo or graphic can be placed on this panel. Mounted with strong, moisture-resistant adhesive backing.

## OPTIONS

For more information, visit [www.hawesco.com](http://www.hawesco.com) or call (888) 640-4297.



## SPECIFICATIONS

The Model 6475 Hydration By Haws™ logo panel attaches to any Haws dual stainless steel fountain, fountain/bottle filler combination that utilizes a back panel, or a Hydration by Haws bottle filler. Easily mounted with strong, moisture-resistant adhesive backing, and template provided for level installation. Panel dimensions: 10"W x 4.25"H

## APPLICATIONS

To cover up existing logos and designs; or logo information is wanted on a fountain or bottle filler installation, the 6475 custom logo panel is ideal.

INSTALLATION INSTRUCTIONS FOR LOGO PLATE:

1. CLEAN THE FRONT OF THE BOTTLE FILLER TO REMOVE ANY GREASE OR CONTAMINANTS.
2. TAPE THE CARDBOARD TEMPLATE ONTO FRONT PANEL OF BOTTLE FILLER, ALIGNING THE TOP AND SIDES OF THE TEMPLATE FLUSH WITH THE EDGES OF BOTTLE FILLER PANEL.
3. REMOVE THE ADHESIVE BACKING FROM LOGO PLATE AND CAREFULLY PLACE INTO THE WINDOW OF THE ALIGNMENT TEMPLATE. PRESS FIRMLY TO SECURE THE LOGO PLATE.
4. REMOVE AND DISCARD THE CARDBOARD TEMPLATE.

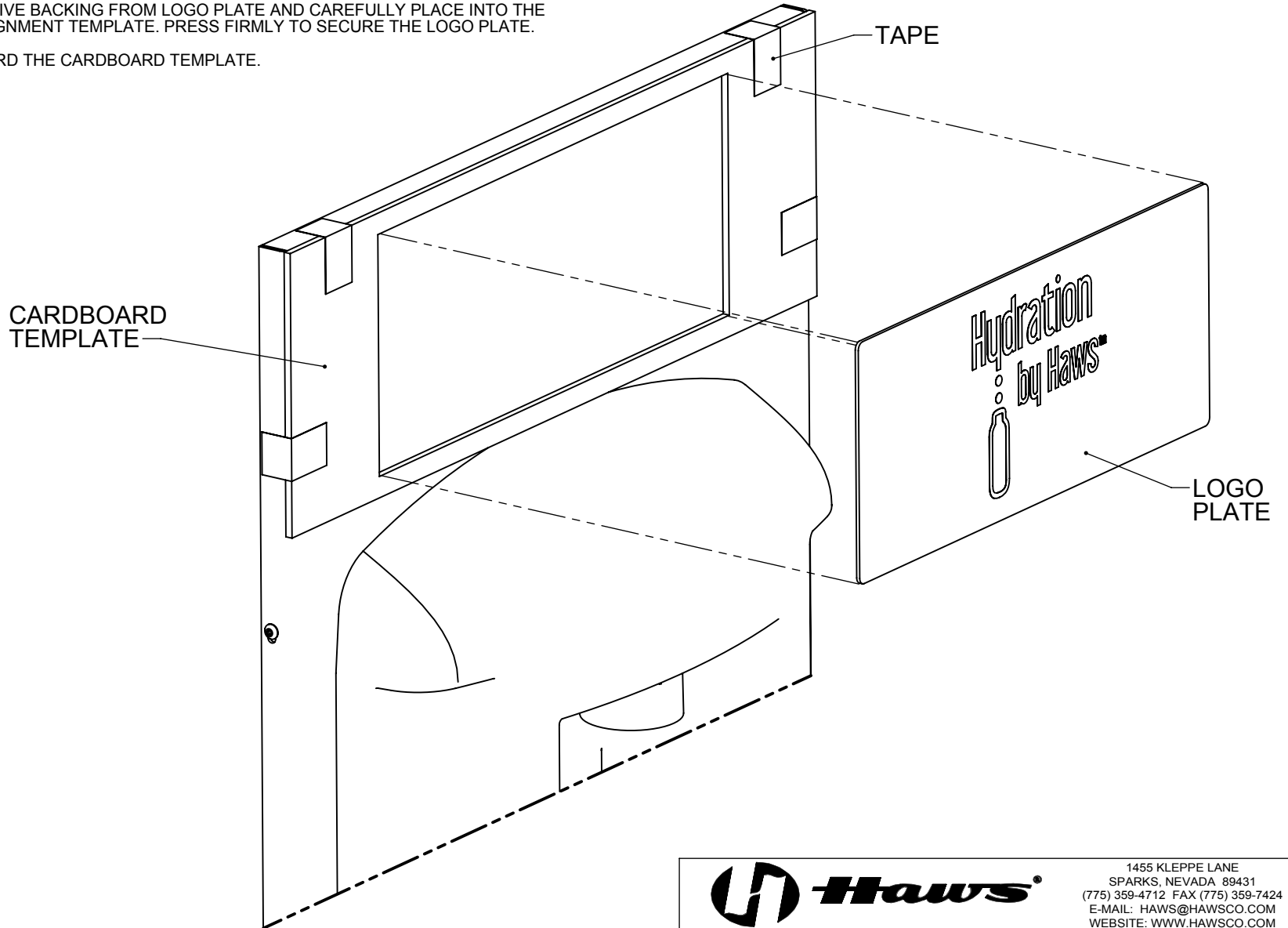

			1455 KLEPPE LANE SPARKS, NEVADA 89431 (775) 359-4712 FAX (775) 359-7424 E-MAIL: HAWS@HAWSO.COM WEBSITE: WWW.HAWSO.COM		
ECN: 5339	REV. ECN: 5339	BY: MJ	MODEL(S)	DRAWING, 6475	PART NUMBER 0580000857.D
DRAWN: MJ	DATE: 08/15/18	CHKD: MJ			REVISION 1
APPROVED: MJ	DATE: 08/15/18	SCALE: 1:4	DRAWING TYPE: INSTALLATION	SIZE: A	SHEET 1 OF 1