



model **5876**

Valve, Solenoid for Haws Electric Water Cooler

FEATURES & BENEFITS

OPTIONS

For more information, visit www.hawSCO.com or call (888) 640-4297.



SPECIFICATIONS

The Haws 5876 electronic push button activated solenoid valve is used with the Haws 1200 series water coolers. 120VAC

APPLICATIONS

This is used with the Haws 1200 series water coolers

REPLACEMENT INSTRUCTIONS:

1. **REQUIRED TOOLS:** RIGHT-ANGLE SCREWDRIVER (SUPPLIED), PHILLIPS SCREWDRIVER
2. REMOVE THE COOLER SKIRT (THE LOWER SKIRT FOR HIGH/LOW MODELS) AND SHUT OFF THE WATER STOP VALVE.
NOTE: SEE WATER COOLER O&M FOR FURTHER DETAILS.
3. **CAUTION:** UNIT IS STILL POWERED ON AT THIS POINT. DISPENSE WATER BRIEFLY TO RELIEVE WATER PRESSURE. UNPLUG THE POWER CORD.
4. DETERMINE THE LOCATION OF THE SOLENOID VALVE FROM THE TABLE BELOW. REMOVE THE LOWER BOWL SUPPORT COVER FROM THE APPROPRIATE UNIT (SEE DIAGRAM TO RIGHT).
5. DISCONNECT THE SOLENOID VALVE WIRING. USE THE SUPPLIED RIGHT-ANGLE SCREWDRIVER (WITH T20 BIT) TO REMOVE THE SOLENOID VALVE MOUNTING SCREWS. DISCONNECT THE PLUMBING.
6. CONNECT THE NEW VALVE TO THE PLUMBING, MAKING NOTE OF THE FLOW DIRECTION ARROW. AFFIX THE VALVE TO THE COOLER FRAME (NEW MOUNTING SCREWS ARE SUPPLIED) AND RE-CONNECT THE WIRING (EACH WIRE MAY CONNECT TO EITHER VALVE TERMINAL).
7. OPEN THE WATER STOP VALVE AND CHECK FOR LEAKS.
8. REASSEMBLE THE COOLER, PLUGGING IN THE POWER CORD BEFORE INSTALLING THE SKIRT. RUN WATER THROUGH THE SYSTEM AND CHECK AGAIN FOR LEAKS.

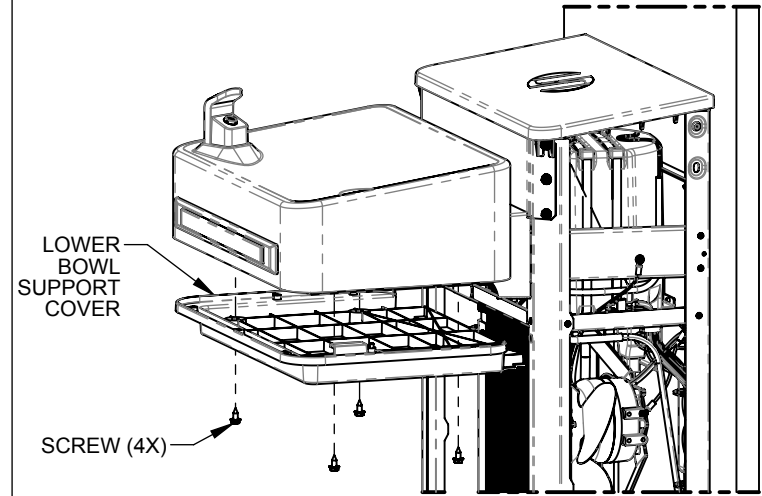

TYPICAL LOWER BOWL SUPPORT COVER REMOVAL

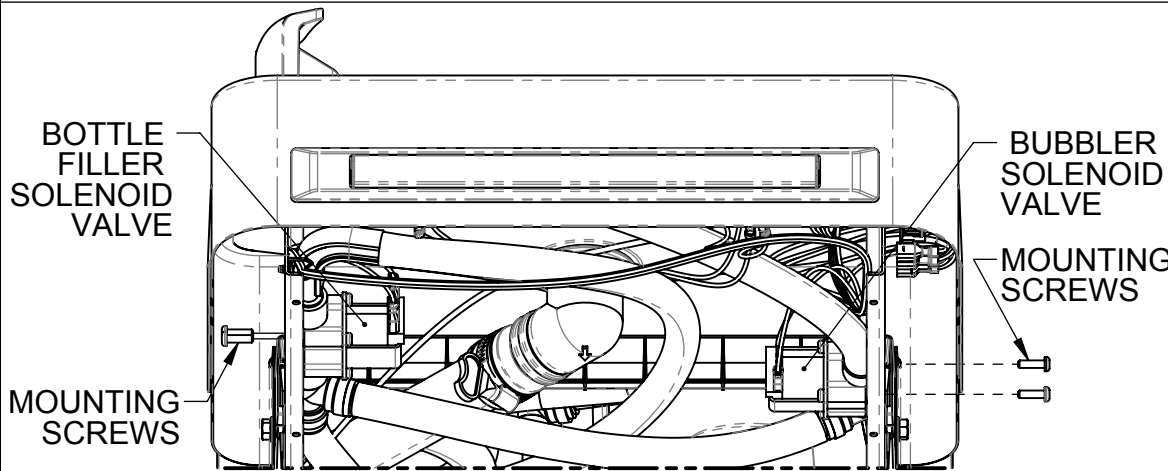

TYPICAL SOLENOID VALVE LOCATIONS

<u>IF THE VALVE CONTROLS:</u>	<u>THE VALVE IS ON:</u>
THE BUBBLER IN A SINGLE-UNIT MODEL	THE RIGHT-HAND BOWL SUPPORT ARM
THE BOTTLE FILLER IN A SINGLE-UNIT MODEL	THE LEFT-HAND BOWL SUPPORT ARM
THE LOW (RIGHT) BUBBLER IN A HIGH/LOW MODEL	THE RIGHT-HAND BOWL SUPPORT ARM IN THE LOW UNIT
HIGH (LEFT) BUBBLER IN A HIGH/LOW MODEL	THE RIGHT-HAND BOWL SUPPORT ARM IN THE HIGH UNIT
THE BOTTLE FILLER IN A HIGH/LOW MODEL	THE LEFT-HAND BOWL SUPPORT ARM IN THE LOW UNIT

SOLENOID VALVE LOCATIONS

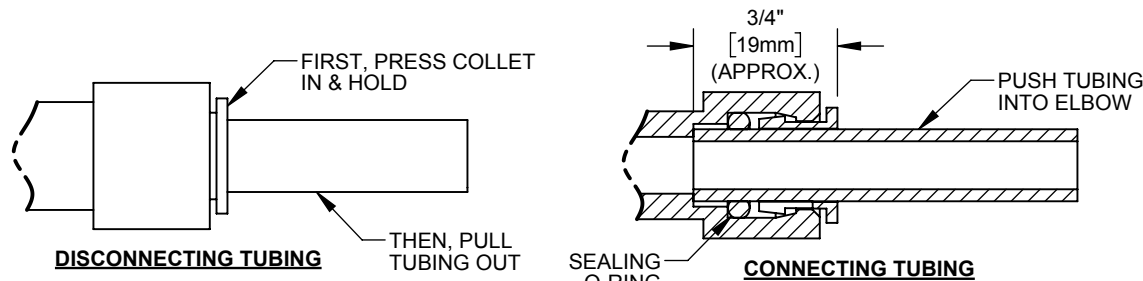

DISCONNECTING & RE-CONNECTING TUBING



1455 KLEPPE LANE
SPARKS, NEVADA 89431
(775) 359-4712 FAX (775) 359-7424
E-MAIL: HAWS@HAWSCO.COM
WEBSITE: WWW.HAWSCO.COM

ECN: 5357	REV. ECN: 5357	BY: JL	MODEL(S)	PART NUMBER
DRAWN: JL	DATE: 04/19/19	CHKD: DHP	5876 -	0510000864
APPROVED: BM	DATE: 06/27/19	SCALE: 1:8	REPLACEMENT 12XX SOLENOID VALVE	REVISION
		DRAWING TYPE: INSTALLATION		1
		SIZE: A		SHEET 1 OF 1